



Operating and Assembly Instructions

Incremental Hollow Shaft Encoder FG6

**Read the operating and assembly instructions prior to assembly,
starting installation and handling!
Keep for future reference!**

Trademark

Brand names and product names are trademarks or registered trademarks of their respective owner. Protected trademarks bearing a ™ or ® symbol are not always depicted as such in the manual. However, the statutory rights of the respective owners remain unaffected.

Manufacturer / publisher

Johannes Hübner
Fabrik elektrischer Maschinen GmbH
Siemensstraße 7
35394 Giessen
Germany
Phone: +49 641 7969 0
Fax: +49 641 73645
E-Mail: info@huebner-giessen.com
Internet: www.huebner-giessen.com

The manual has been drawn up with the utmost care and attention. Nevertheless, we cannot exclude the possibility of errors in form and content. It is strictly forbidden to reproduce this publication or parts of this publication in any form or by any means without the prior written permission of Johannes Hübner Fabrik elektrischer Maschinen GmbH.

Subject to errors and changes due to technical improvements.

Copyright © Johannes Hübner Fabrik elektrischer Maschinen GmbH.
All rights reserved.

Table of contents

1 General	5
1.1 Information about the operating and assembly instructions	5
1.2 Scope of delivery	5
1.3 Explanation of symbols	5
1.4 Disclaimer	6
1.5 Copyright	6
1.6 Guarantee terms	6
1.7 Customer service	6
2 Safety	6
2.1 Responsibility of the owner	6
2.2 Intended use	6
2.3 Non- intended use	7
2.4 Personal protective equipment	7
2.5 Personnel	7
2.6 Special dangers	7
2.6.1 Electrical current	7
2.6.2 Rotating shafts / Hot surfaces	7
2.6.3 Safeguarding against restart	7
3 Technical Data	8
3.1 Type plate	8
3.2 Electrical and mechanical data	9
3.3 Type code	11
4 Transport, packaging and storage	12
4.1 Safety instructions for transport	12
4.2 Incoming goods inspection	12
4.3 Packaging / (disposal)	12
4.4 Storage of packages (devices)	12
5 Installation and commissioning	13
5.1 Safety instructions	13
5.2 Mounting of the hollow shaft encoder (mechanically)	13
5.2.1 Assembly instruction for hollow shaft devices	13
5.2.1 Assembly of a hollow shaft encoder FGH 6 and additionally a further encoder in construction type B5 onto the NDE of the FGH 6	15
5.3 Connecting the hollow shaft encoder	16
5.3.1 Connections	16
5.3.2 Connection with integrated EGS® 4 technology in the second terminal box (option S)	16
The connections for the EGS® 4 technology are accommodated in the second terminal box of the hollow shaft encoder.	16
5.3.3 Technical notes	17
6 Disassembly of the hollow shaft encoder	17
6.1 Safety instructions	17
7 Faults	18
7.1 Faults table	18

8 Inspections	19
8.1 Safety instructions	19
8.2 Maintenance information	19
8.3 Inspection schedule	19
9 Disposal	19
9.1 Disposal procedure	19
9.2 Accessories (not included in the scope of delivery)	20
10 Dimension drawings	21
11 Connection Diagrams	31
12 Mounting instructions for coupling	33

1 General

1.1 Information about the operating and assembly instructions

This operating manual provides important instructions for working with the device. It must be carefully read prior to starting all tasks, and the instructions contained herein must be followed.

In addition, applicable local regulations for the prevention of industrial accidents and general safety regulations must be complied with.

1.2 Scope of delivery

Incremental Hollow Shaft Encoder FGH 6, operating and assembly instructions.

1.3 Explanation of symbols

Warnings are indicated by symbols in this operating manual. The warnings are introduced by signal words that express the scope of the hazard.

The warnings must be strictly heeded; you must act prudently to prevent accidents, personal injury, and property damage.



WARNING!

Indicates a possibly dangerous situation that can result in death or serious injury if it is not avoided.



CAUTION!

Indicates a possibly dangerous situation that can result in minor injury if it is not avoided.



CAUTION!

Indicates a possibly dangerous situation that can result in material damage if it is not avoided.



NOTES!

Indicates useful tips and recommendations as well as information for efficient and trouble-free operation.



NOTES!

Do not use a hammer or similar tool when installing the device due to the risk of damage occurring to the bearings or coupling!



DANGER!

Life-threatening danger due to electric shock!

Indicates a life-threatening situation due to electric shock. If the safety instructions are not complied with there is danger of serious injury or death. The work that must be executed should only be performed by a qualified electrician.

1.4 Disclaimer

All information and instructions in this operating manual have been provided under due consideration of applicable guidelines, as well as our many years of experience.

The manufacturer assumes no liability for damages due to:

- Failure to follow the instructions in the manual
- Non-intended use
- Deployment of untrained personnel
- Opening of the device or conversions of the device

In all other aspects the obligations agreed in the delivery contract as well as the delivery conditions of the manufacturer apply.

1.5 Copyright



NOTES!

Content information, text, drawings, graphics, and other representations are protected by copyright and are subject to commercial property rights. It is strictly forbidden to make copies of any kind or by any means for any purpose other than in conjunction with using the device without the prior written agreement of the manufacturer. Any copyright infringements will be prosecuted.

1.6 Guarantee terms

The guarantee terms are provided in the manufacturer's terms and conditions.

1.7 Customer service

For technical information personnel are available that can be reached per telephone, fax, email, or via the Internet, see manufacturer's address on page 2.

2 Safety



DANGER!

This section provides an overview of all the important safety aspects that ensure protection of personnel, as well as safe and trouble-free device operation. If these safety instructions are not complied with significant hazard can occur.

2.1 Responsibility of the owner

The device is used in commercial applications. Consequently the owner of the device is subject to the legal occupational safety obligations and subject to the safety, accident prevention and environmental protection regulations that are applicable for the device's area of implementation.

2.2 Intended use

The device has been designed and constructed exclusively for the intended use described here.

Series FGH 6 incremental hollow-shaft encoders are used for measurement of rotations, for instance of electrical and mechanical drives and shafts.

Claims of any type due to damage arising from non-intended use are excluded; the owner bears sole responsibility for non-intended use.

2.3 Non- intended use

The device may not be used in explosion-threatened areas.

On the device no other mechanical load may be exercised except his dead weight and the oscillations without fail appearing during the company and pushes.

Examples of inadmissible mechanical charges (incomplete listing):

- Connection of transport or lifting means in the device, e.g., load hook for raising of an engine.
- Connection of packaging parts in the device, e.g., instep belts, tarpaulin, etc.
- Use of the device as a step, e.g., for going up of a person on an engine.

2.4 Personal protective equipment

For tasks such as assembly, disassembly or commissioning the use of personal protective equipment such as safety footwear and protective work clothing is required.

The regulations specified by the owner and that are locally specified apply.

2.5 Personnel

Only skilled technical staff is allowed to perform installation, mounting, disassembly and commissioning work.

2.6 Special dangers

Residual risks that have been determined based on a risk analysis are cited below.

2.6.1 Electrical current



DANGER!

Life-threatening danger due to electrical shock!

There is an imminent life-threatening hazard if live parts are touched. Damage to insulation or to specific components can pose a life-threatening hazard.

Therefore:

Immediately switch off the device and have it repaired if there is damage to the insulation of the power supply.

De-energize the electrical equipment and ensure that all components are connected for all tasks on the electrical equipment.

Keep moisture away from live parts. Moisture can cause short circuits.

2.6.2 Rotating shafts / Hot surfaces



WARNING!

Danger of injury due to rotating shafts and hot surfaces!

Touching rotating shafts can cause serious injuries.

Therefore:

Do not reach into moving parts/shafts or handle moving parts/shafts during operation.

Close to protect from injury all access openings in flanges with the corresponding plug screw, and provided you exposed rotating components with protective covers.

Do not open covers during operation. Prior to opening the covers ensure that all parts have come to a standstill.

The encoder can become hot during prolonged use.

In case of contact risk of burns is existing.

2.6.3 Safeguarding against restart



DANGER!

Life-threatening danger if restarted without authorization!

When correcting faults there is danger of the power supply being switched on without authorization.

This poses a life-threatening hazard for persons in the danger zone.

Therefore:

Prior to starting work, switch off the system and safeguard it from being switched on again.

3 Technical Data

3.1 Type plate

Type plate example:

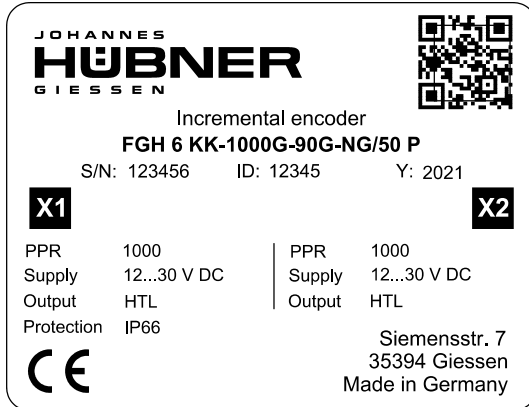

The type plate is located on the side of the housing and contains the following information:

- Manufacturer, Address, CE-mark
- Type
- Serial number (S/N)
- Date of manufacturing (Y)
- Number of pulses (PPR)
- Degree of protection (IP)
- Supply
- Output
- ID number
- QR-code

3.2 Electrical and mechanical data

Pulse rates		Value		
Preferred pulse rates (nickel disks)		1024, 2000		
Pulse rates available		256, 600, 1000, 1200, 1920, 2048, 2500, 4000, 4096,5000		
Connection data				
Supply voltage		12 ... 30 VDC (Option: 5 VDC)		
No load-current		approx. 100 mA at 30 V (without Option)		
Outputs		Differential line-driver, resistant to sustained short-circuit, current limited, short-circuit.		
Pulse height (HTL)		approx. as supply voltage		
Internal resistance		50 Ω per output		
Pulse height (TTL)		5 V to RS 422		
Slew rate		50 V / μs		
Pulse duty factor		1 : 1 ± 5 %		
Square wave displacement 0°, 90°		to 50 KHz < 3 % to 150 KHz < 5 %		
Max. frequency		0 to 100 kHz. (to 150 kHz on request)		
Encoder temperature ranges				
Standard		0°C ... + 70°C		
Special temperature		-25°C ... + 85°C		
Special output voltage 5V (TTL)				
Pulse height		5V, RS422 compatible (TIA/EIA-Standard)		
Supply voltage		12 ... 30 VDC		
Protection class DIN EN 60529	Sealing	Mechanical speed	Description	Breakaway torque
IP 54	Special seal	≤ 4000 rpm	Protection against dust and water spray	approx. 30 to 50 Ncm
IP 66 only drive side	Radial shaft seal	≤ 1500 rpm	Protection against dust and water spray	approx. 60 Ncm
IP 66 both sides	Radial shaft seal	≤ 1100 rpm	Protection against dust and water spray	approx. 70 Ncm
Weight	Type K Type KK			6 kg 6,8 kg

Signal outputs																			
<p>Basic version (n = pulses/revolution). One pulse channel (basic) with n direct square wave pulses, corresponding to the segment division and LED monitoring output. (optional conditional).</p>																			
<p>Option 90 2nd pulse channel as basic version, bit with 90° electrical phase shift.</p>																			
<p>Option N / N2 Marker pulse, mechanically fixed. One square wave pulse per revolution.</p>																			
<p>Option G Additional inverted output signals for basic and 90° channels, marker pulse plus LED check.</p>																			
<p>Option F With 2 or 4 times as many pulses as basic version, No direction of motion can be derived from the multiple number of pulses</p>																			
<p>Option B Fast and precise sensing of rotational direction at each edge of the basic and 90° channels. Prerequisite: Option 90°</p>	<table border="1" style="margin-left: auto; margin-right: auto;"> <thead> <tr> <th rowspan="2"></th> <th colspan="2" style="text-align: center;">Output</th> <th rowspan="2"></th> </tr> <tr> <th style="text-align: center;">L</th> <th style="text-align: center;">R</th> </tr> </thead> <tbody> <tr> <td style="text-align: center;">cw</td> <td style="text-align: center;">0</td> <td style="text-align: center;">1</td> <td style="text-align: center;">Option B, B2</td> </tr> <tr> <td style="text-align: center;">ccw</td> <td style="text-align: center;">1</td> <td style="text-align: center;">0</td> <td style="text-align: center;">Option B2</td> </tr> <tr> <td style="text-align: center;">Still stand</td> <td style="text-align: center;">0</td> <td style="text-align: center;">0</td> <td style="text-align: center;">Option B2</td> </tr> </tbody> </table>		Output			L	R	cw	0	1	Option B, B2	ccw	1	0	Option B2	Still stand	0	0	Option B2
	Output																		
	L	R																	
cw	0	1	Option B, B2																
ccw	1	0	Option B2																
Still stand	0	0	Option B2																
<p>Option B2 As option B, but with standstill sensing.</p>																			
<p>Option V Electronic pulse doubling of basic and 90° channels by multiple evaluation.</p>																			
<p>Option L2 Power output up to 150 mA for basic channel, 90° channel and the corresponding inverted signals.</p>																			
<p>Option J Reduced rotational frequency modulation by means of optically adjusted pulse disk</p>																			
<p>Option J50 Specially adjusted pulse disc. Rotational vibration < 50 seconds of arc.</p>																			
<p>Option S Electronic overspeed switch with 2 programmable switching outputs, EGS4 version (see operating and assembly instructions EGS 4).</p>																			

3.3 Type code

	FGH	I	6	K	1000	G	90 G	NG	2F	S	J	/50P
Incremental Hollow Shaft Encoder												
Synthetic bushing												
Series												
Connection K: Terminal box S: Industrial plug R: 12 pole. round plug C: 2 m connection cable L: fiber optics- technic 2x connection = redundant Encoder or Encoder with Option S e.G.. KK = 2 terminal boxes												
Pulses per revolution												
Basic signal output Basic channel 0° (A) Pulse channel 90° (B) Each with inverted signals												
Reference pulse with inverted signal 2 F: Option 2F 4 F: Option 4F B: Option B B2: Option B2 S: Option S EGS® 4 Technic 2nd terminal box L2: Option L2												
V: Option V J: Option J and J50 can be combined with V												
Drive shaft connection P: keyway S: pressure sleeve C: taper												

4 Transport, packaging and storage

4.1 Safety instructions for transport



CAUTION!

Material damage caused by improper transport!

Observe the symbols and information on the packaging:

- Do not throw - risk of breakage
- Keep dry
- Do not expose to heat above 40 °C or direct sunlight.

4.2 Incoming goods inspection

Check delivery immediately upon receipt for completeness and possible transport damage.

Inform the forwarder directly on receipt of the goods about existing transport damages (prepare pictures for evidence).

4.3 Packaging / (disposal)

The packaging is not taken back and must be disposed of in accordance with the respective statutory regulations and local guidelines.

4.4 Storage of packages (devices)



Keep dry

Keep packages dry and free from dust; protect from moisture.

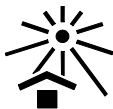

Protect against heat

Protect packages from heat above 40 °C and direct sunlight.

If you intend to store the device for a longer period of time (> 6 months) we recommend you use protective packaging (with desiccant).



NOTES!

Turn the shaft of the device every 6 month 10 times to prevent the bearing grease solidifying, which may lead to the destruction of the device.

5 Installation and commissioning

5.1 Safety instructions

Personnel

Installation and commissioning must be carried out by qualified personnel only.



WARNING!

Observe the safety instructions contained in **Chapter Fehler!** Verweisquelle konnte nicht gefunden werden. when installing or working on the device!
Assembly, disassembly and other work on the device may only be performed by qualified personnel!

5.2 Mounting of the hollow shaft encoder (mechanically)



NOTES!

Do not use a hammer or similar tool when installing the device due to the risk of damage occurring to the bearings or coupling!

5.2.1 Assembly instruction for hollow shaft devices

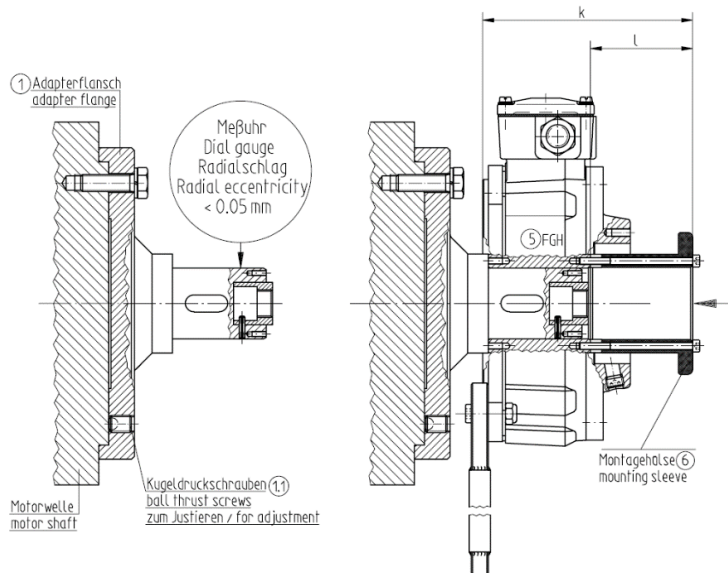

Figure 1

Mount the adapter flange (1) and align precisely with dial gauge. Figure 1 page 13.



NOTES!

The radial deviation of the shaft (2) Figure 2 page 14 should not exceed 0,05 mm.
If necessary, use the ball thrust adjustment screw to align the adapter shaft. Secure ball thrust screws with Loctite® 243. Remove unused ball thrust screws or secure with Loctite® 243. Max. tightening torque for M12 approx. 24 Nm, for M16 approx. 63 Nm.
Use parallel keys to DIN 6885.



NOTES!

The hollow shaft encoder must slide smoothly onto the adapter shaft. Do not push on with increased force; otherwise, the bearings may be damaged. If necessary, rework the adapter shaft and key with emery cloth. Do not strike the device hard against the shaft collar. Pay attention to the position of the key.

A mounting sleeve is available as an accessory for easier mounting. The hollow shaft encoder can also be mounted without a mounting sleeve.

- 1 The hollow shaft of the hollow shaft encoder has threaded holes on both ends. If simple mounting of the hollow shaft encoder (5) is not possible, we recommend using the mounting sleeve. Fasten the mounting sleeve (Figure 1 page 13) (accessory ID-10595) there with 4 screws M5x80. The mounting sleeve can now be used to apply pressure to the encoder shaft until the hollow shaft encoder is seated against the stop of the shaft collar.
- 2 Remove the mounting sleeve and keep it for disassembly.
- 3 Screw the hollow shaft encoder to the hollow shaft using the axial clamping ring (3) and fastening screws (4) 4x M5 x 16 - DIN 912. Figure 2 page 14).
- 4 Screw the axial clamping ring with fastening screws (6) 4x M4 x 20 - DIN 912 onto the adapter shaft.
- 5 Close the hollow shaft encoder with the cover plate with seal (7).
- 6 Attach the torque bracket/support arm (8) to the hollow shaft encoder.

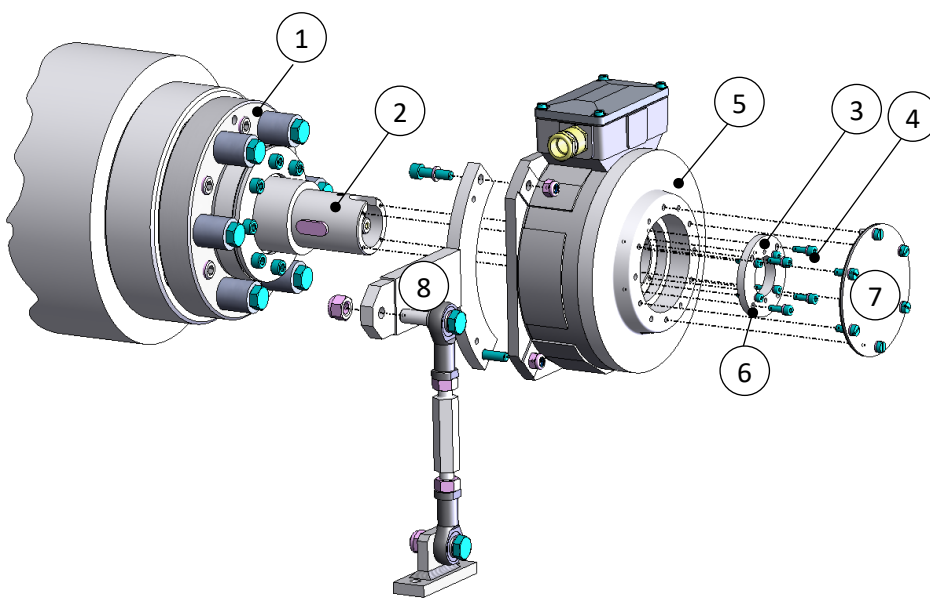

Figure 2



NOTES!

When fitting to the device, it is possible to align the torque bracket in four different directions.

- 7 Fastening the torque bracket:

Fastening without base plate:

Secure the link rod head of the link rod to a fixed point (for example on the motor housing).

Fastening with base plate:

Secure the base plate to a fixed point with screws (for example on the motor housing or the foundations).



NOTES!

Once fitted the link rod must rotate easily around the link rod heads! Failure to observe this point may result in damage to the bearings!

The perfect angle from the torque bracket (2) to the link rod (7) should be 90°.

The link heads are maintenance free. However, ensure they remain free from soiling and paint!

5.2.1 Assembly of a hollow shaft encoder FGH 6 and additionally a further encoder in construction type B5 onto the NDE of the FGH 6



Assembly with metal bellows coupling:

1. Mount the adapter shaft onto the motor shaft.
2. Put the coupling (metal bellows coupling) on adapter shaft extension and fix the encoder with a set screw.
3. Put the hollow shaft encoder FGH 6 onto the shaft that has been **lightly** greased and fix with suitable axial tightening disc and screw. Details see chapter 5.2.1.
4. Put the to be coupled encoder onto the B14 flange of the hollow shaft encoder FGH 6. Put the shaft carefully in the coupling bore. (Attention: The bore in the B 14 flange must show in the direction of the set screw). Slide the rear encoder up to the mechanical stop and tighten it with suitable screws.
Tighten the rear set screw of the coupling through the access of the B14 flange.
Then close the access with a lock screw.
See dimension drawing HM 14 M 108191.

5.3 Connecting the hollow shaft encoder

5.3.1 Connections

Cable glands are closed with a stopper to protect the devices on transport and storage.

Cable connections:

Have to be executed according to the encoder type.

Connection diagrams have to be considered!

To fulfil degree of protection requirements the diameter of the connection cable must correspond to that of the cable gland (please refer to Chapter 10, Dimension drawings). Cable outlet should show preferably downwards.

5.3.2 Connection with integrated EGS® 4 technology in the second terminal box (option S)

The connections for the EGS® 4 technology are accommodated in the second terminal box of the hollow shaft encoder.



Important instruction

For the function of the hollow shaft encoder, the voltage supply for the EGS® 4 technology in the second terminal box is also to be connected.

Wiring arrangement and shielding:

(EMC measurement)

The cable shielding must be connected on both sides.

The shield of the signal cable is directly connected to the housing of the encoder by the cable gland.

The common guidelines for EMI concerned cable routing have to be considered!

Sample Figure

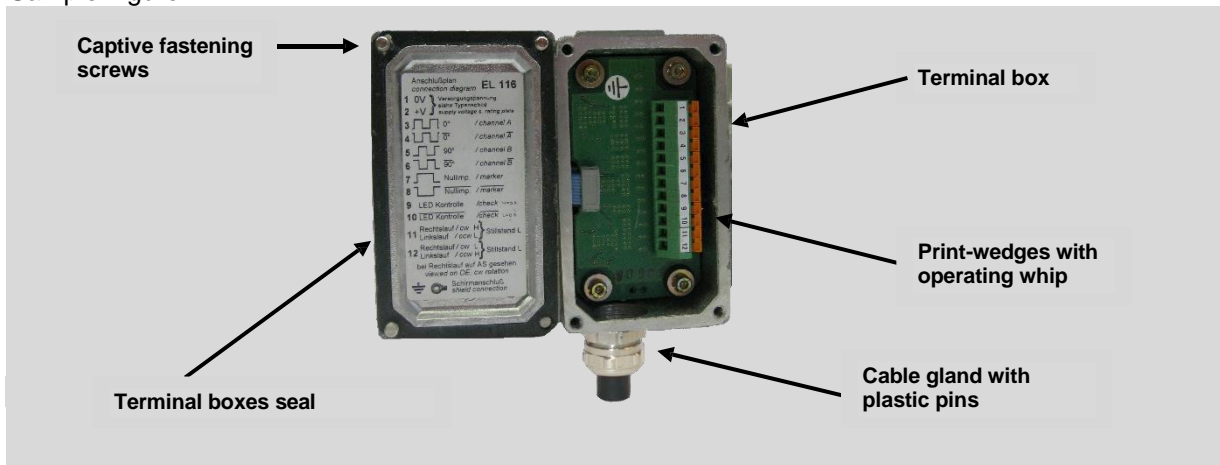

Important instruction

The hollow shaft encoder may only be connected by skilled technical staff.

Closing the terminal box cover

Check the seal of the terminal box cover, clean it if soiled. Then duly close the cover.



Cable must not be pinched.

Attention with open terminal boxes.

Moisture should not get into the terminal box when connecting the cable.

5.3.3 Technical notes

Ambient temperature

The max. permissible ambient temperature depends on speed and protection class (shaft sealing) of the encoder as well as on frequency, signal cable length and mounting situation. See chapter 3.2

Protection class

To comply with the protection class the signal cable diameter must be appropriate to the cable gland! See chapter 5.3.1.

6 Disassembly of the hollow shaft encoder



NOTES!

If the device cannot be pulled off the adapter shaft by hand after removing the axial clamping ring, use the mounting sleeve (page 13).

The mounting sleeve allows the hollow shaft encoder to be removed from the adapter shaft without the risk of ball bearing damage.

- 1 Remove the axial clamping ring, torque bracket and electrical connection.
- 2 The hollow shaft of the hollow shaft encoder has threaded holes on both ends. To dismantle the hollow shaft encoder, the mounting sleeve (Figure 2 page 14) is screwed on there with 4 screws M5x80. The hollow shaft encoder can now be carefully pulled off the adapter shaft using a suitable pulling device (Figure 3 page 17).

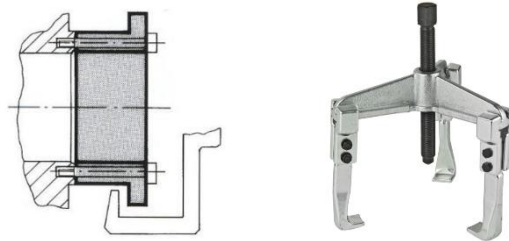

Figure 3

6.1 Safety instructions



Personnel

Disassembly of the hollow shaft encoder from the system may only be carried out by qualified personnel.

Attention: It is essential to observe the safety instructions in **chapter 2** before carrying out any work (installation/maintenance/dismantling) on the device.

7 Faults

7.1 Faults table

Faults	Possible cause	Remedy
Moisture in the terminal box	Soiled terminal box gasket or seal surfaces	Clean terminal box gasket and seal surfaces
	Damaged terminal box gasket	Replace terminal box gasket
	Cable gland/blanking plug not tightened	Tighten cable gland/blanking plug
	Unsuitable cable for cable gland	Use suitable cable and cable glands
No output signals	Supply voltage not connected	Connect supply voltage
	Connection cable reversed	Wire correctly
Output signals subject to interference	Unsuitable cable	Use data cable with conductors arranged as twisted pairs and common shield
	Cable shield not connected	Connect cable shield at both ends
	Cable routing not EMC compliant	Observe applicable EMC guidelines when routing cables
Signal interruptions	Signal end stage overloaded	Check pin assignment; observe connection diagram
		Do not assign unused outputs
	Outputs short-circuited	Do not connect outputs with supply voltage or GND
No function at hollow shaft encoders with EGS® 4 technology in the second terminal box (option S)	Supply voltage for the EGS® 4 technology not connected in the second terminal box.	Connect the power supply for the EGS® 4 technology in the second terminal box.
Contact Hübner-Service (page 2) if none of the remedies listed above provides a solution!		

8 Inspections

8.1 Safety instructions



Personnel

Skilled technical staff only are permitted to inspect the device and its installation.

Caution: Observe the safety instructions contained in **chapter 2** when inspecting or working on the device.

8.2 Maintenance information

The device is maintenance free. However the following tests are recommended to ensure optimal, problem free operation.

8.3 Inspection schedule

Interval	Inspections
Yearly	Inspect the coupling for damage and ensure it is free of play
	Ensure the fastening screws are properly tightened
	Ensure cable connections and connection terminals are securely seated
Following approx 16 000 ... 20 000 hours of operation / higher levels of continuous load	Check deep groove ball bearings are running smoothly and listen for running noises

9 Disposal

9.1 Disposal procedure

The manufacturer is not obliged to take back electronics waste. The device consists of hybrid components, and in part must be disposed of as special waste (electronic scrap) according to country-specific legislation.

Local municipal authorities or specialized disposal companies provide information on environmentally responsible disposal.

9.2 Accessories (not included in the scope of delivery)

The additional installation of a cover for adapter shafts is possible in the way shown

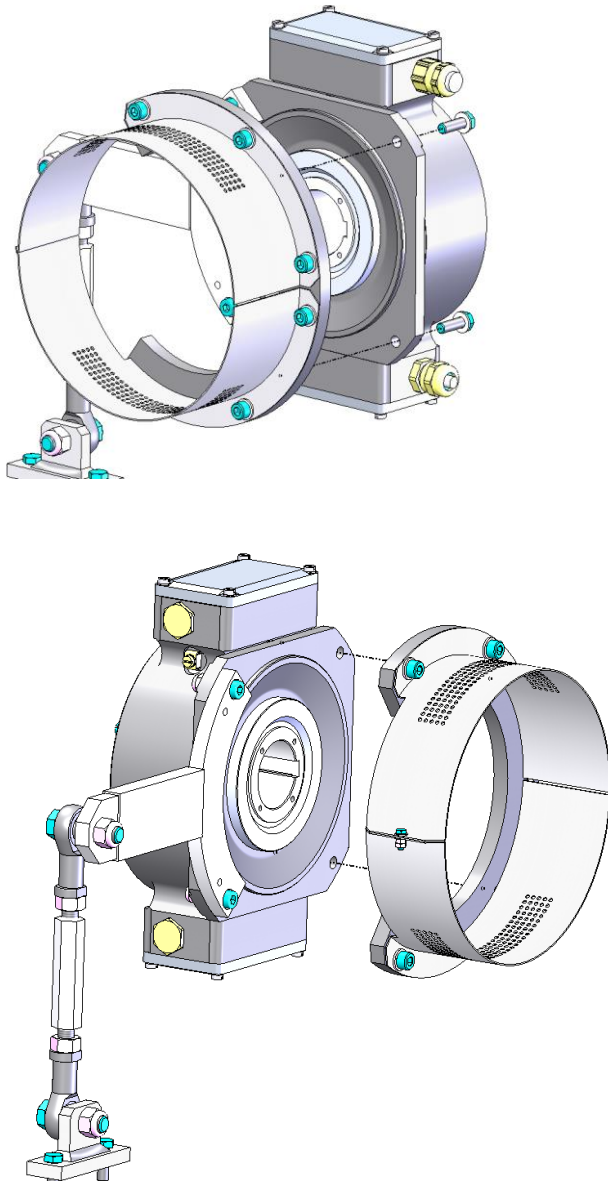

The recess of the cover and the shape of our torque supports are designed in such a way that they can be mounted as desired (4x 90°) on two flange holes each.

The cover, which is divided into two halves, enables retrofitting to the mounted encoder. For individual dimensions and instructions, see the dimensional drawing of the particular kit.

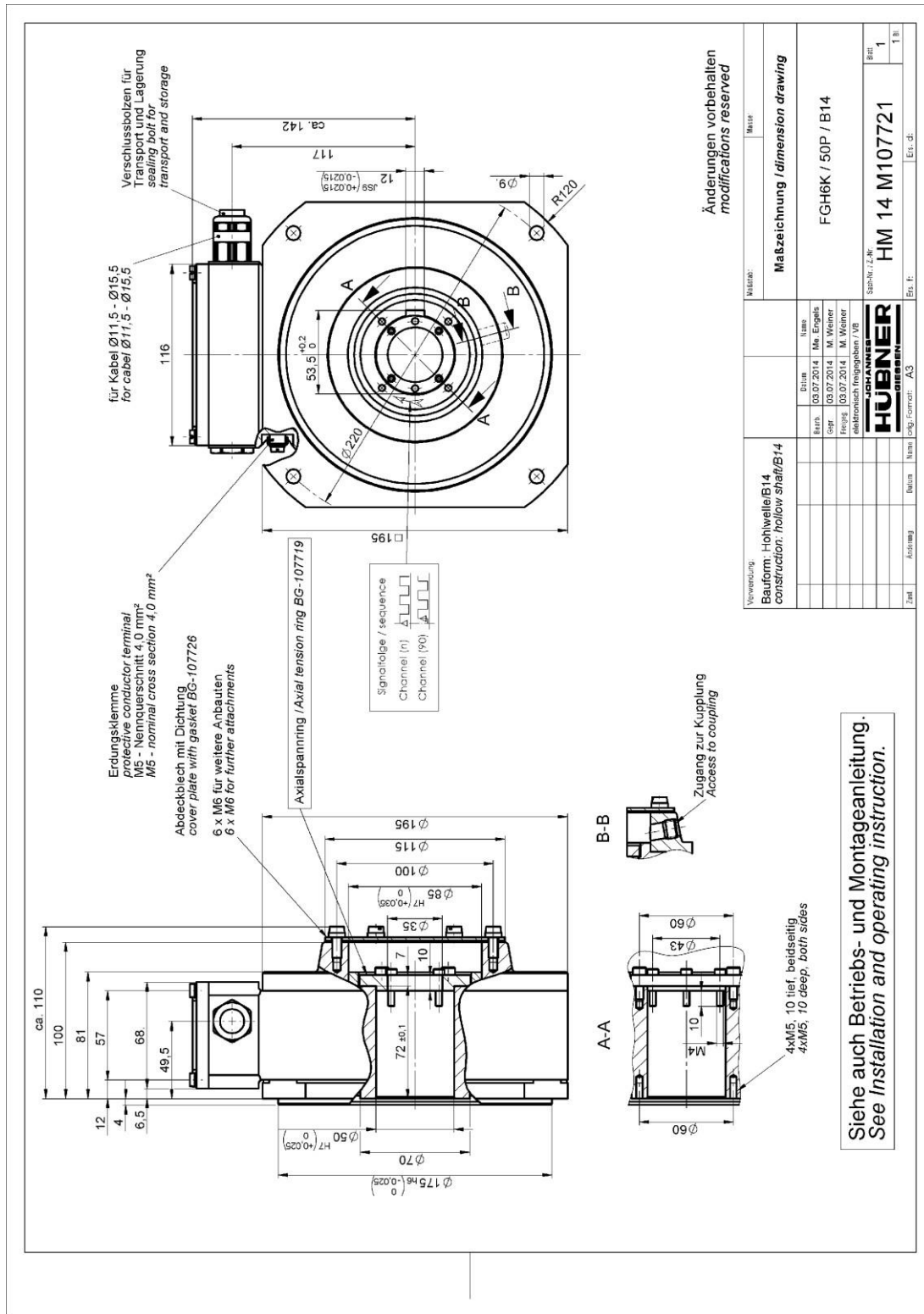

FGH 6 K.../50P/B14

B 14-flange

HM 14 M 107721

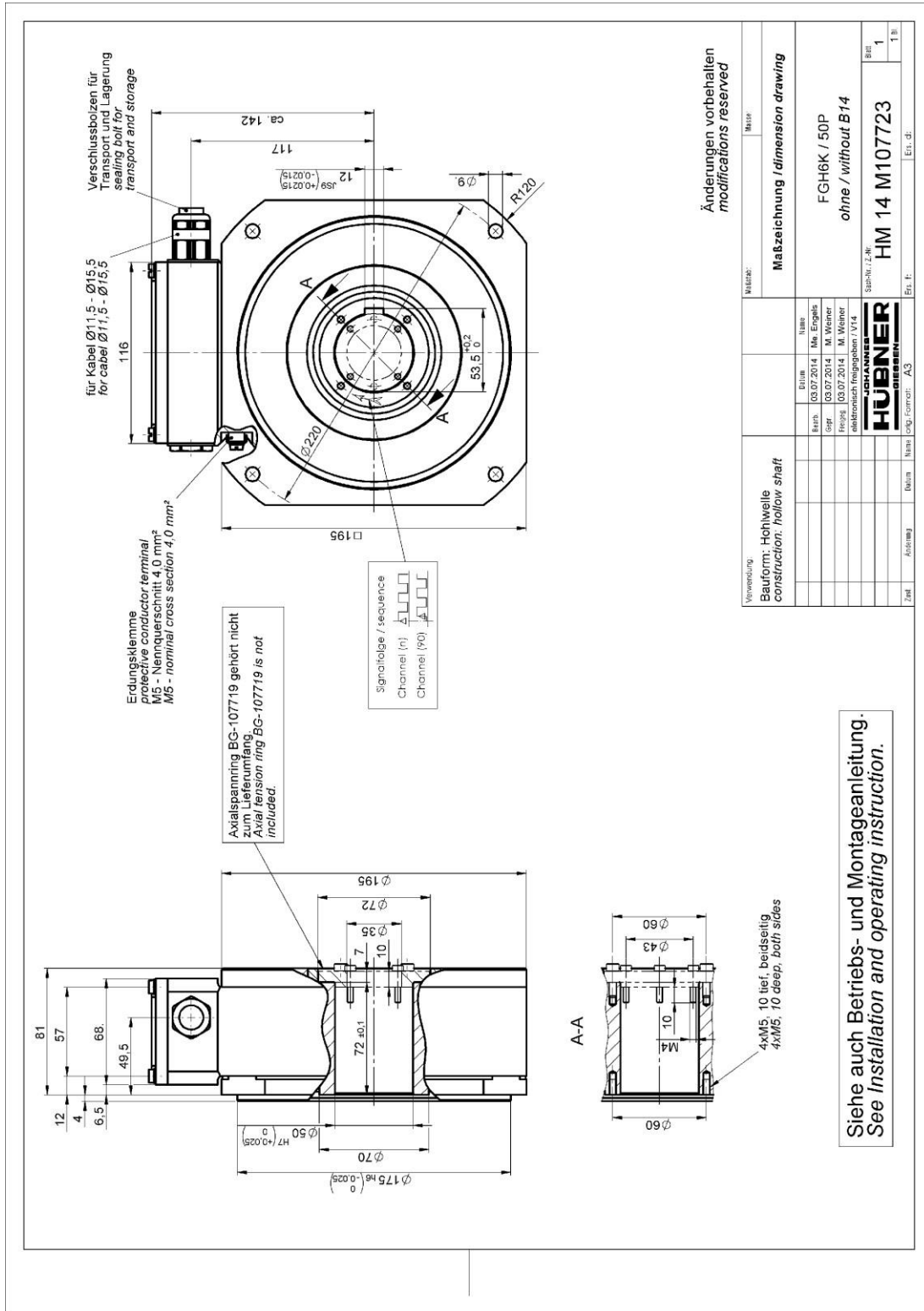

FGH 6 K.../50P

HM 14 M 107723

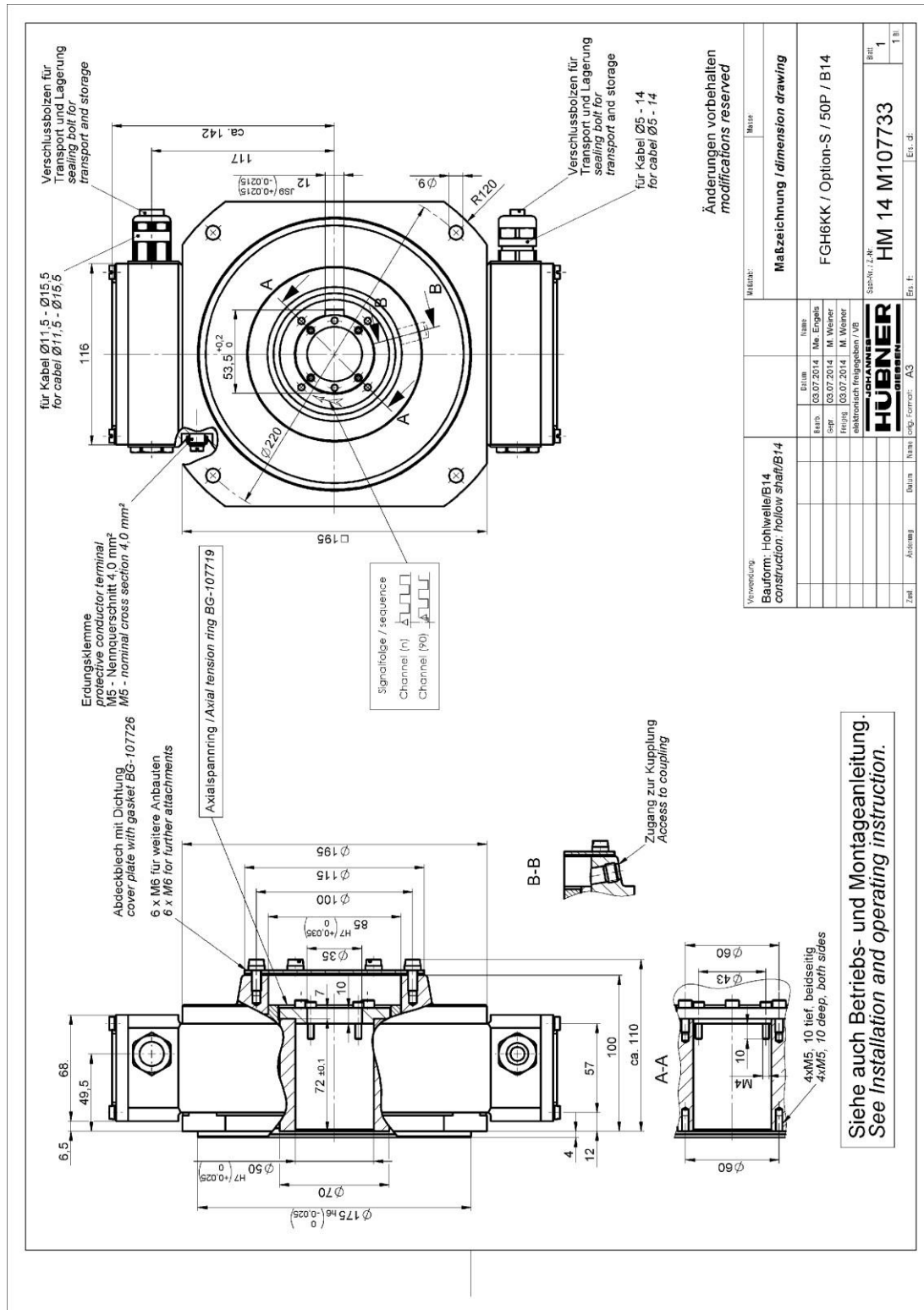

FGH 6 KK.../50P/B14

KK redundant version with
B14-flange and integrated Option S

HM 14 M 107733

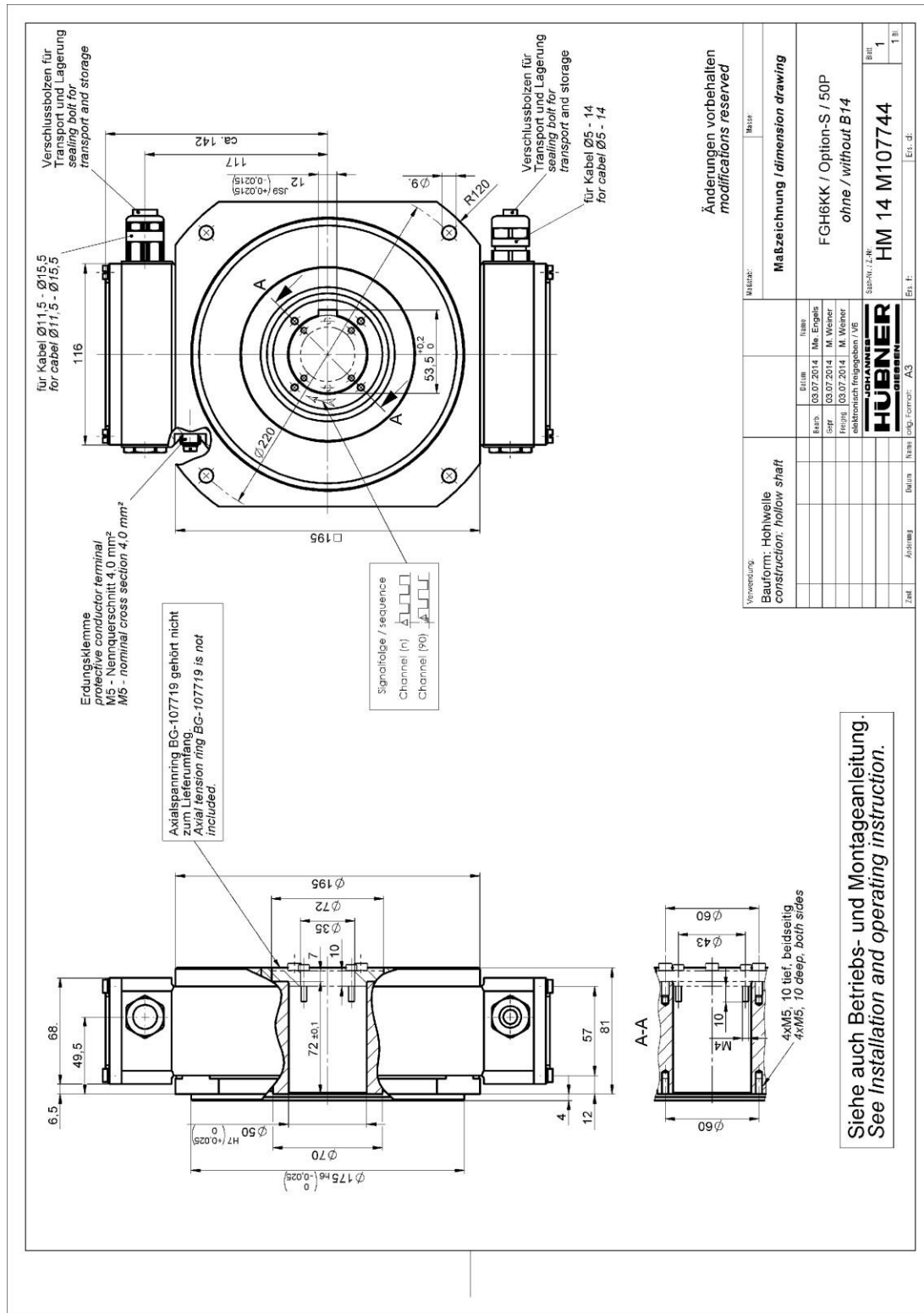

FGH 6 KK.../50P

KK redundant version with integrated Option S

HM 14 M 107744

11 Connection Diagrams

12-pol. Bandklemme Typ Phoenix
12-pole strip clamping type Phoenix

Schirmung:
Der Schirm der Signalleitung ist über die Kabelverschraubung direkt mit dem Gehäuse verbunden.
Shield:
The shield of the signal cable is directly connected with the housing of the encoder by the cable gland.

	EL 816	EL 816-1	EL 816-2	EL 816-3	EL 816-4	EL 816-5	EL 816-6	EL 816-7
0V	1	1	1	1	1	1	1	1
+ ... V ¹⁾	2	2	2	2	2	2	2	2
0°	3	3; 7	3	3	3	3	3	3
0°	4	4; 8	4	4	4	4	4	4
90°	5	5; 9	5	5	5	5	5	5
90°	6	6; 10	6	6	6	6	6	6
N	7	---	---	7	7	7	---	7
N	8	---	---	8	---	8	---	8
M	9	11	9	9	8	9	9	---
M	10	12	10	10	---	10	10	---
2F	---	---	7	11	9	---	---	11
4F	---	---	8	12	10	---	7	12
4F	---	---	---	---	---	---	8	---
R	11	---	11	---	11	---	11	9
L	12	---	12	---	12	---	12	10
Schaltausgang 1	---	---	---	---	---	11	---	---
Schaltausgang 2	---	---	---	---	---	12	---	---

+ ... V¹⁾ Versorgungsspannung nach Typenschildangabe
supply voltage see rating plate

Verwendung: FG .. (A)K

Allgemeintoleranzen DIN ISO 2768m

OFZ nach DIN ISO 1302

Maßstab:
 Werkstoff:

Datum:
 Name:
 Bearb. 03.06.14
 DirIam:
 Gepr.:
 Norm:

Benennung: **Anschlussplan**
Connection diagram

Zeichnungs Nr.: EL 816
 Blatt: Bl.

Die Belegung der Anschlüsse Availability of options ist aus der Typenbezeichnung ersichtlich see type description

z.B. e.g.: FG..K-1000 G - 90 G - N G

0° channel A
0° inv. channel A inv.
90° channel B
90° inv. channel B inv.
Nullimpuls marker
Nullimp.inv. marker inv.

FGH 6 Standard Terminal box

Anschlusskabel direkt angelötet
6x2x0,56 paarig verseilt, geschirmt
Connection cable soldered-on directly
6x2x0,56 twin-stranded, shielded

rot red — + (12 - 30)V } Versorgungsspannung
schwarz black — 0V } supply voltage

orange orange — 0° / channel A
schwarz black — 0° inv. / channel A inv.

blau blue — 90° / channel B
schwarz black — 90° inv. / channel B inv.

gelb yellow — Nullimpuls / marker
schwarz black — Nullimpuls inv. / marker inv.

grün green — LED Kontrolle / check H = o.k.
schwarz black — LED Kontrolle inv. / check inv. L = o.k.

braun brown — Rechtslauf / cw H } Stillstand L
schwarz black — Linkslauf / ccw L }
Rechtslauf / cw L } Stillstand L
Linkslauf / ccw H }

Schirm ist mit Gehäuse verbunden
shield is connected to casing
alternativ/alternative
Der Schirm der Signalleitung ist über die Kabelverschraubung direkt mit dem Gehäuse verbunden.
The shield of the signal cable is directly connected with the housing of the encoder by the cable gland.

Typ : HE-2LVCC-CY AWG 20B
VDE 0881 zugelassen
acc. to VDE 0881

Querschnitt: 0,56 mm?
cross-section
Temperatur: -30°C bis +105°C
temperature
fest verlegt
fixed installation
bewegt
flexing
Außendurchmesser: 10,1 mm
Outside dia

Verwendung: FG...C

Allgemeintoleranzen DIN ISO 2768m

OFZ nach DIN ISO 1302

Maßstab:
 Werkstoff:

Datum:
 Name:
 Bearb. 11.12.91
 Martis:
 Gepr.:
 Norm:

Benennung: **Anschlussplan**
Connection diagram

Zeichnungs Nr.: EL 205
 Blatt: Bl.

Die Belegung der Anschlüsse Availability of options ist aus der Typenbezeichnung ersichtlich see type description

z.B. e.g.: FG.C-1000 G - 90 G - N G

0° channel A
0° inv. channel A inv.
90° channel B
90° inv. channel B inv.
Nullimpuls marker
Nullimp.inv. marker inv.

FGH 6 Standard Connection cable

Ansicht auf Steckdoseneinsatz
Socket insert view

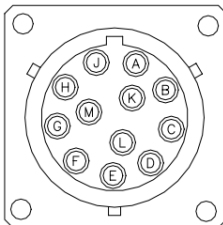

Crimpkontakte für Drahtquer-
schnitte 0,52 bis 1,5 mm²
*Crimp contacts for cross-sectional
data of wire from 0.52 up to 1.5 mm²*

Schirmung:
Der Schirm der Signalleitung ist direkt
mit dem Steckergehäuse zu verbinden.
*Shield:
The shield of the signal cable is directly
to be connected with the socket housing*

Crimpzange: Burndy Nr. MR 8 GE 5
Crimping tool: Burndy No. MR 8 GE 5

Die Belegung der Anschlüsse Availability of options
ist aus der Typen- see type description
bezeichnung ersichtlich

z.B. e.g.: FG..R-1000 G - 90 G - N G

- 0° channel A
- 0° inv. channel A inv.
- 90° channel B
- 90° inv. channel B inv.
- Nullimpuls marker
- Nullimp.inv. marker inv.

	EL 161	EL 161-1	EL 161-2
0V	A	A	A
+ ... V ¹⁾	B	B	B
0°	C	C	C
0°	D	D	D
90°	E	E	E
90°	F	F	F
N	G	G	G
N	H	H	H
M	J	J	---
M	K	K	---
2F	---	---	J
4F	---	---	K
R	L	---	L
L	M	---	M
Schalt- gang 1	---	---	---
Schalt- gang 2	---	---	---

+ ... V¹⁾ Versorgungsspannung nach Typenschildangabe
supply voltage see rating plate

Verwendung: FG .. R	Allgemein- toleranzen DIN ISO 2768m	OFZ nach DIN ISO 1302	Maßstab: Werkstoff:
a EL 161-2	17.05.94 Ma	Datum: Name	Benennung: Anschlußplan Connection diagram
		Bearb. 12.06.91 Martis	
		Gepr.	
		Norm	
			Zeichnungs Nr.: EL 161
Zust.	Änderung	Datum: Name	Blatt Bl.

FGH 6

Standard

12 - pole plug

Ansicht auf Steckdoseneinsatz
Socket insert view

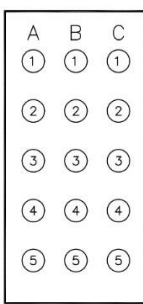

Crimpkontakte für Drahtquer-
schnitte 0,75 bis 1,0 mm²
*Crimp contacts for cross-sectional
data of wire from 0.75 up to 1.0 mm²*

Crimpzange: Harting Nr. 09 99 000 0110
Ausdrückwerkzeug: Harting Nr. 09 99 000 0012
Crimping tool: Harting No. 09 99 000 0110
Removal tool: Harting No. 09 99 000 0012

Schirmung:
Der Schirm der Signalleitung muss über
die Kabelverschraubung direkt mit dem
Gehäuse verbunden werden.
*Shield:
The shield of the signal cable has to be
connected directly to the housing of the
encoder by the cable gland.*

Die Belegung der Anschlüsse Availability of options
ist aus der Typen- see type description
bezeichnung ersichtlich

z.B. e.g.: FG..S-1000 G - 90 G - N G

- 0° channel A
- 0° inv. channel A inv.
- 90° channel B
- 90° inv. channel B inv.
- Nullimpuls marker
- Nullimp.inv. marker inv.

	EL 064	EL 064-1
0V	C5	C5
+ ... V ¹⁾	A5	A5
0°	A1	A1
0°	A2	A2
90°	A3	A3
90°	A4	A4
N	B3	B3
N	B4	B4
M	B5	B5
M	C3	C3
2F	C4	C4
4F	B2	---
R	C1	C1
L	C2	C2
Schalt- gang 1	---	B1
Schalt- gang 2	---	B2

+ ... V¹⁾ Versorgungsspannung nach Typenschildangabe
supply voltage see rating plate

Verwendung: FG .. S	Allgemein- toleranzen DIN ISO 2768m	OFZ nach DIN ISO 1302	Maßstab: Werkstoff:
a dt. / engl.	20.03.96 Ma	Datum: Name	Benennung: Anschlußplan Connection diagram
b EMV-Harting	29.04.11 Di	Bearb. 24.09.92 Martis	
		Gepr.	
		Norm	
			Zeichnungs Nr.: EL 064
Zust.	Änderung	Datum: Name	Blatt Bl.

FGH 6

Standard

EMC industrial plug

12 Mounting instructions for coupling

	Montageanleitung für Kupplungen Mounting Instructions for Couplings	NR. 54 690 S.1 Datum: 06/2009
---	--	---

Kupplungsbohrung – Passung G7 oder H7 – d. h.: Toleranzfeld liegt oberhalb der Nulllinie.
= **Kupplung muß leichtgängig aufziehbar sein** =

Bohrungen vor der Endmontage prüfen evtl. nachreiben, dann leicht einfetten.

Mindestens eine Nabe, mit Radialgewindestift mit Spitze/Ringschneide, gegen Axialverschiebung befestigen. Gewindestift drückt auf Paßfeder, damit Welle nicht beschädigt wird.

Beachte: **zulässige Nachgiebigkeiten!** sind voneinander abhängig – siehe Rückseite

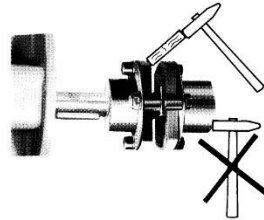

Coupling bore – fit – G7 or H7
i. e.: tolerance range is above the reference line
= **Fit the coupling smoothly** =

Please refinish coupling bores prior to final mounting, if necessary finish-ream and grease bores slightly.

Provide axial fastening on shaft by radial set screw. Fasten at least one set screw with coned point/cupped gripping point to avoid axial offset. Set screw pushes onto the feather key to prevent shaft from damage.

Note: **admissible resilienties!** are dependent on each other see backside

Anbaufehler:

- bewirken Radialkräfte, diese können die Geberlager und die Kupplung beschädigen oder zerstören!
- Verschlechtern **Signalqualität!** Verstärkt **Oberwelligkeit und Drehschwebung!**

Je **genauer** der Anbau, um so **höher** die Lebensdauer der Kupplung/Geberlager, um so **präziser** die Ausgangssignale!

Mounting failures!

- **Misalignment** can cause radial forces which may damage the coupling or destroy the encoder bearings!
- **Signal quality can be affected, rotational frequency modulation and interferences (ripple) may occur.**

The more precise the mounting, the higher the service life of the coupling and the bearings of the encoders.

Kupplung Typ HK.. 5-

durch Deformation bei Montage, beim Überschreiten der zulässigen Nachgiebigkeiten kann der **Federstahl-Ausgleichsring Ø 54 mm** beschädigt werden.



Coupling Type HK.. 5-

by deformation caused by wrong mounting and if permissible resilienties will be exceeded, spring steel compensating element dia 54 mm can be damaged.

Balgkupplungen Typ EK.. / DKN..:

Bei der Montage/Demontage **kritisch** – **Bruchgefahr des Faltenbalges** – vor allem bei der Demontage feststehender Wellenzapfen.

Verwendung von rostlösendem Gleitspray o.ä., Radialgewindeschrauben vorher lösen. Kupplung vorsichtig an den Naben abdrücken. Reservekupplung einplanen.



Metal bellows coupling type EK/DKN..

Critical fitting/removal
Bellows may brake above all while removing from the tight shaft extension.

For removal it is recommended to use an antirust/ anticorrosion spray and to unscrew the radial set screw. Press on the hubs carefully when removing the coupling. Spare coupling should be available

Steckkupplungen Typ HK7-HK45:

Bei der Montage ist die **axiale Lage** der **Kupplungshälften** zu **beachten**, ein **ausreichender Abstand** von 1 – 2 mm zum **Kunststoffstern** sind einzuhalten, damit dieser **nicht gequetscht** wird und die elektrische Isolierung erhalten bleibt. **Abstandsverhältnisse müssen ausgemessen werden**, damit **keine** zusätzliche **axiale Verspannkraft** entsteht, die sich sehr **nachteilig** auf die **Lagerlaufzeit** und auf die **Ausgangssignale** auswirkt!



Push-on coupling HK7 up to HK 45

For mounting please consider **axial position** of coupling halves. A **distance** of 1 – 2 mm to the Plastic tooth ring must be maintained in order to **prevent** it from **squeezing** and to protect the electrical insulation. **Distance relation of coupling parts must be measured** to avoid axial forces affecting both the **service life** of the bearings and the **output signals!**

JOHANNES HÜBNER · Fabrik elektrischer Maschinen GmbH

Siemensstrasse 7 · D-35394 Giessen/Germany

Tel. +49 641/79 69-0 · Fax +49 641/7 36 45 · email: info@huebner-giessen.com

www.huebner-giessen.com