

Checklist for encoder installation

Sender			
Company:		Contact person:	
		Phone:	
Address:		Fax:	
		Email:	
Mounting site:			
Date:			

1 Mounting solid-shaft encoders with flange (B5)

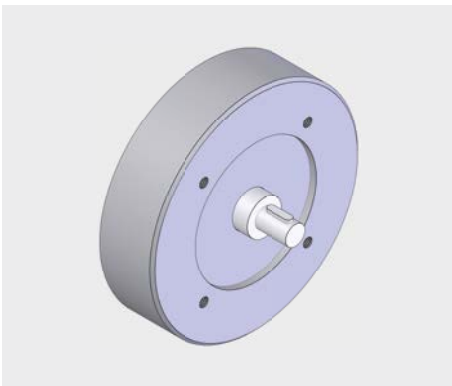

a. Mounting site / customer shaft

- I. Clean the mounting site and fastening threads.
- II. Clean and lightly grease the shaft and centering.

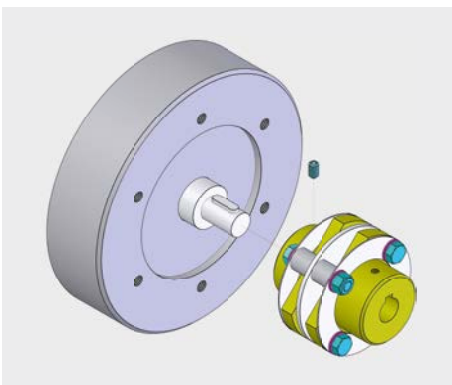

b. Mounting the coupling on the customer shaft

- I. Install the coupling smoothly. If necessary, adjust the drill holes of used couplings.
- II. Fix the coupling hub using a grub screw or regular screw (depending on the coupling design).
- III. Optional: Use an insulated coupling to protect against shaft currents.

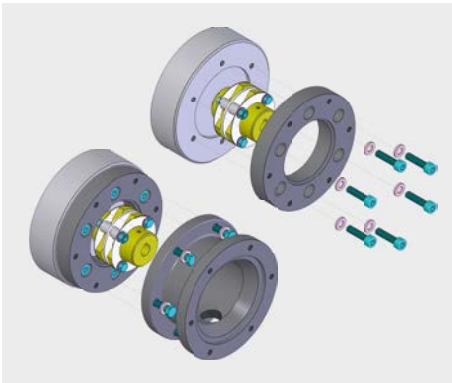

c. Attach intermediate flange and spacer if necessary

- I. Lightly grease the centering.
- II. Position the lock screw downward.

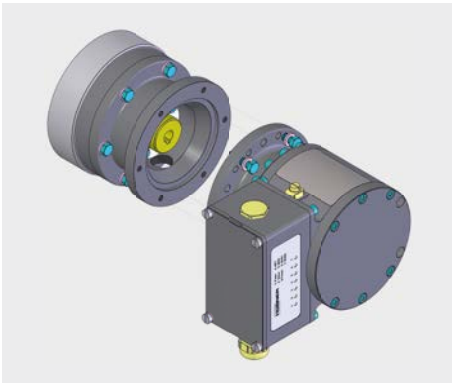

d. Insert encoder into coupling and intermediate flange

- I. Lightly grease the shaft.
- II. Align cable outlets downward or to the side.

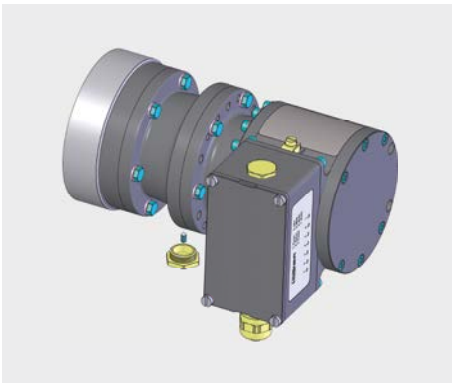

e. Attach encoder to coupling and intermediate flange

- I. Secure the encoder to the intermediate flange using screws.
- II. Unscrew the lock screw from the intermediate flange.
- III. Fix the coupling hub on the encoder shaft using a set grub screw or regular screw.
- IV. Retighten the lock screw on the intermediate flange.

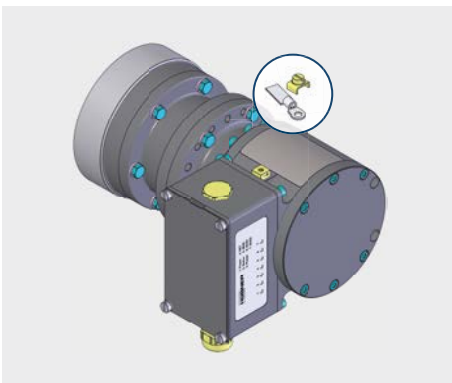

f. Ground the encoder using the grounding strap

2 Mounting solid-shaft encoders with base and flange (B35)

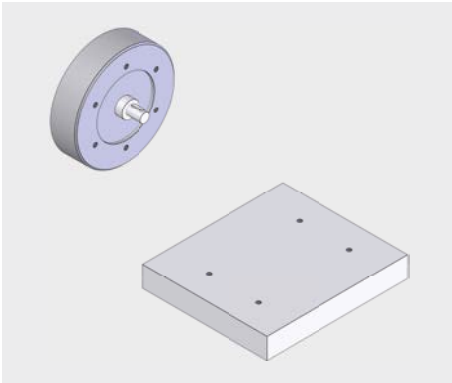

a. Mounting site / customer shaft

- I. Clean the mounting site.
- II. Clean and lightly grease the shaft.

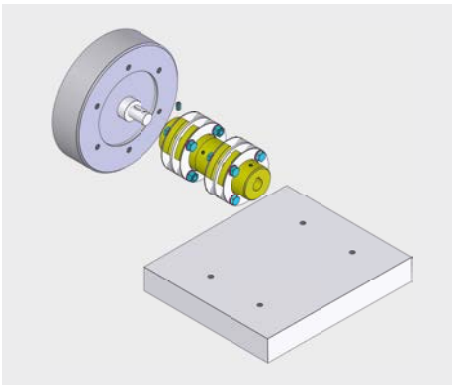

b. Mounting the coupling on the customer shaft

- I. Install the coupling smoothly. If necessary, adjust the drill holes of used couplings.
- II. Fix the coupling hub using a grub screw or regular screw (depending on the coupling design).
- II. Optional: Use an insulated coupling to protect against shaft currents.

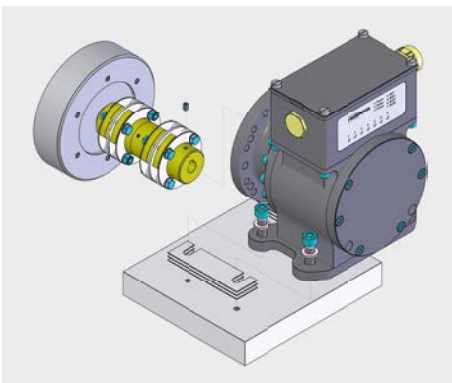

c. Install the encoder

- I. Lightly grease the encoder shaft and insert the encoder into the coupling.
- II. Attach the encoder to the base using screws. Compensate for lateral misalignment if necessary.
- III. Adjust vertical misalignment with spacer plates if required.
- IV. Fix the coupling hub on the encoder shaft using a grub screw or regular screw.

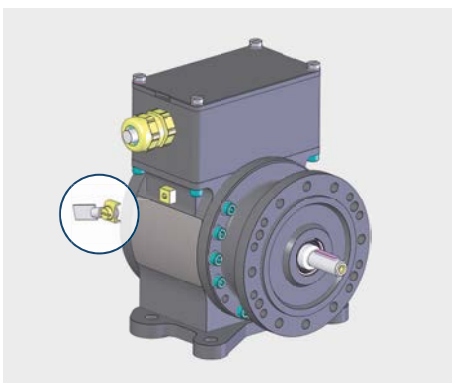

d. Ground the encoder using the grounding strap

3 Mounting hollow-shaft encoders

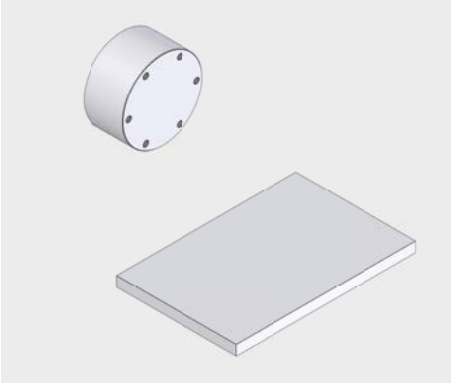

a. Mounting site / customer shaft

- I. Clean the mounting site and fastening threads.
- II. Clean and lightly grease the shaft and centering.

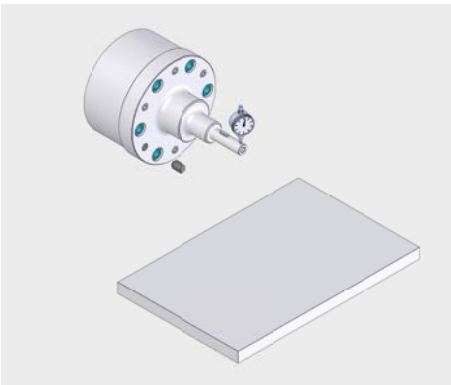

b. Mount adapter shaft on customer shaft and align with dial gauge

- I. Lightly grease the adapter shaft.
- II. Ensure the radial runout of the adapter shaft does not exceed 0.05 mm.
- III. Use ball-thrust adjustment screws for alignment if necessary. Secure the adjustment screws with Loctite® 243. Remove unused screws or secure them as well.
- IV. Optional: Use an insulated adapter shaft to protect against shaft currents.

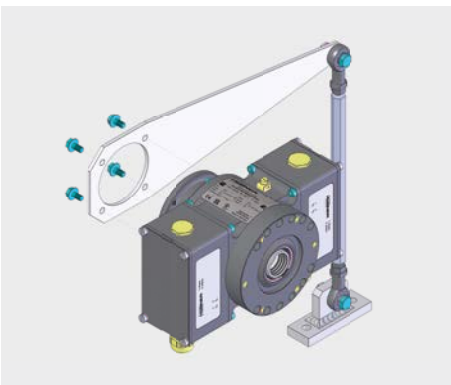

c. Attach support arm of torque bracket to hollow-shaft encoder

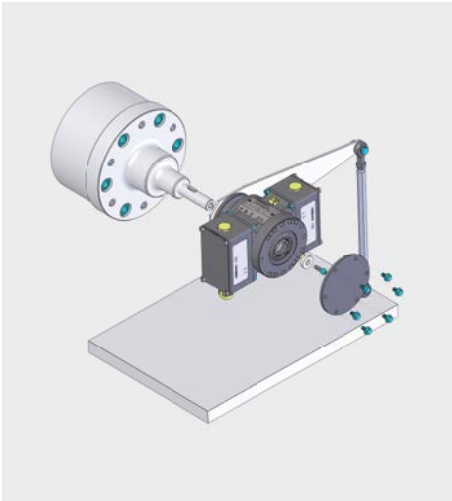

d. Mount encoder on adapter shaft

- I. Remove the back cover of the encoder if necessary.
- II. Slide the hollow-shaft encoder smoothly onto the adapter shaft.
- III. Avoid hard contact with the shaft shoulder.
- IV. Align cable outlets downward or to the side.
- V. Secure the encoder.
- VI. Reattach the back cover of the encoder if necessary.

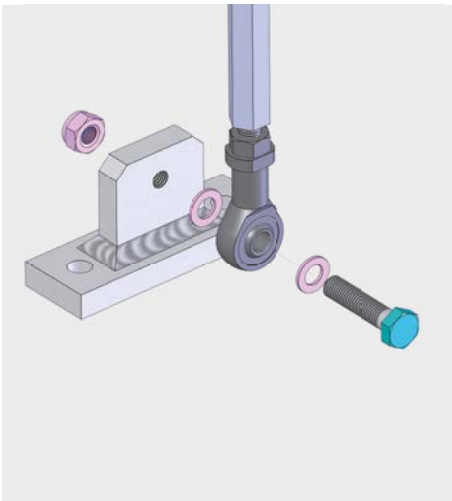

e. Attach torque bracket

- I. Without a base plate: Secure the free joint head of the torque arm directly to a fixed point, e.g. motor housing.
- II. With a base plate: Secure the base plate with screws to a fixed point, e.g. motor housing or foundation.
- III. Ensure the ideal angle between the support arm and the torque arm is 90°.
- IV. Ensure joint heads can rotate freely.
- V. Keep joint heads free of dirt or paint.
- VI. Optional: Use an insulated torque bracket.



f. Ground the encoder using the grounding strap

4 Electrical connection

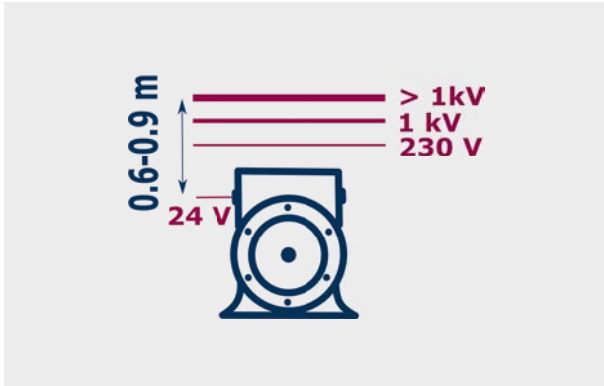

a. Maintain sufficient distance from power cables.

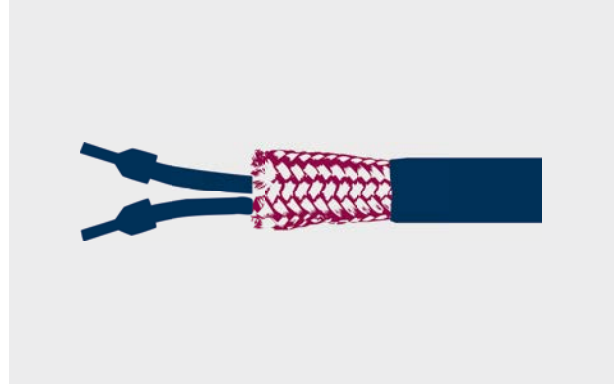

b. Use shielded cables.

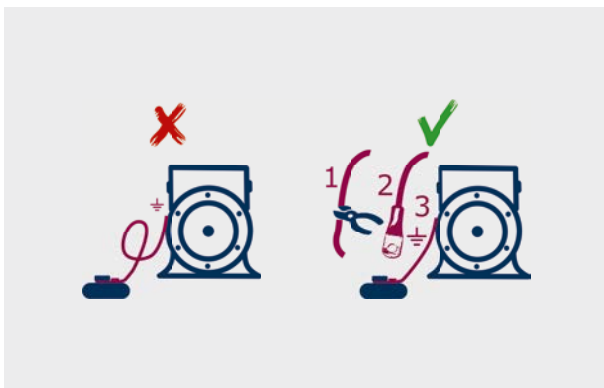

c. Place the shielding of the connection cable close to the power source using suitable clamps. Ensure a large-area connection to the ground. The grounding point must be metallic, clean, and free of paint, non-conductive coatings, grease, oil and corrosion.

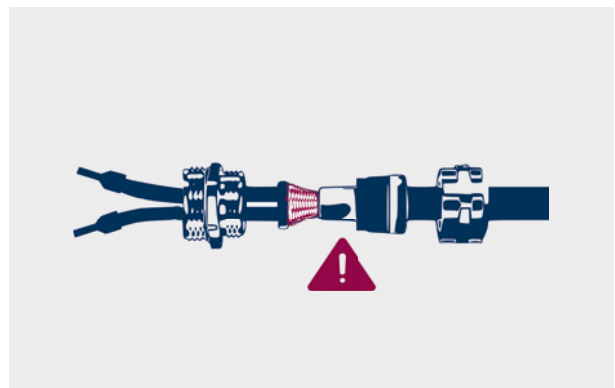

d. Shield connection in cable gland.

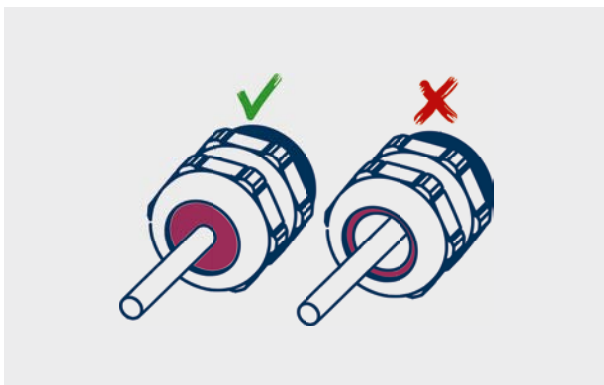

e. Use cable glands with strain relief and appropriate sealing inserts for the cable diameter.

f. Data cables for absolute encoders

- I. Use cables with a manufacturer's declaration, e.g. PROFINET or PROFIBUS.
- II. Connect shielding at the encoder and in the control cabinet.
- III. Securely fasten connectors.