

Operating and Assembly Instructions

Absolute Encoder

multiturn with Profibus® Interface

AMP 40

**Read the Operating and Assembly Instructions prior to assembly, starting installation and handling!
Keep for future reference!**

Trademark

Brand names and product names are trademarks or registered trademarks of their respective owner. Protected trademarks bearing a ™ or ® symbol are not always depicted as such in the manual. However, the statutory rights of the respective owners remain unaffected.

Manufacturer / publisher

Johannes Hübner Fabrik elektrischer Maschinen GmbH
Siemensstr. 7
35394 Giessen
Germany

Telephone: +49 641 7969 0

Fax: +49 641 73645

Internet: www.huebner-giessen.com

E-Mail: info@huebner-giessen.com

This manual has been drawn up with the utmost care and attention. Nevertheless, we cannot exclude the possibility of errors in form and content. It is strictly forbidden to reproduce this publication or parts of this publication in any form or by any means without the prior written permission of Johannes Hübner Fabrik elektrischer Maschinen GmbH.

Johannes Hübner Fabrik elektrischer Maschinen GmbH is listed by Underwriters Laboratories.

UL certificates can be requested from us.

An overview of our UL devices can be found at the following link:

<https://iq.ulprospector.com/info>

UL File Number: E351535

Subject to errors and changes due to technical improvements.

Copyright © Johannes Hübner Fabrik elektrischer Maschinen GmbH
All rights reserved.

Directory

1	General	5
1.1	Information about the Operating and Assembly instructions	5
1.2	Scope of delivery	5
1.3	Explanation of symbols	5
1.4	Disclaimer	6
1.5	Copyright	6
1.6	Guarantee terms	6
1.7	Customer service	6
2	Safety	6
2.1	Responsibility of the owner	6
2.2	Intended use	6
2.3	Non- intended use	7
2.4	Personnel	7
2.5	Personal protective equipment	7
2.6	Special dangers	8
2.6.1	Electrical current	8
2.6.2	Rotating shafts / hot surfaces	8
2.6.3	Safeguarding against restart	8
3	Technical Data	9
3.1	Type plate	9
3.2	Type code	9
3.3	Electrical and mechanical data	10
4	Transport, packaging and storage	11
4.1	Safety instructions for transport	11
4.2	Incoming goods inspection	11
4.3	Packaging / disposal	11
4.4	Storage of packages (devices)	11
5	Installation and commissioning	12
5.1	Safety instructions	12
5.2	Technical information	12
5.3	Required tools	12
5.4	Mounting preparations	13
5.5	Mounting B5 type (flange) encoders	13
5.6	Mounting B35 type (flange and foot) absolute encoders	15
5.7	Mounting tolerances for construction type B5 and B35	16
5.8	Installation	17
5.8.1	General rules	17
5.8.2	Connecting	18
5.8.3	Shield contacting for EMC cable gland with cone	18
5.8.4	Work steps for bus cover connection	19
5.8.5	Technical information	20

5.9	Maintenance information	20
5.10	Inspection schedule	20
6	Installation and commissioning.....	21
6.1	User manual	21
6.2	Profibus profile for the absolute encoder	21
6.3	Joining the encoder to the Profibus	22
6.4	Configuring the encoder	23
6.5	Parameterizing the encoder	23
6.6	Parameterization in hex code	24
6.7	Operating the encoder in the Huebner 2.1 and Huebner 2.2 profiles	24
6.8	Desired measuring units per	25
6.8.1	Desired measuring units per revolution	25
6.8.2	Desired measuring units per maximum total measuring range	25
6.8.3	Desired measuring units per physical pulse	26
6.9	Commissioning mode	26
6.10	Limit switches	26
6.11	Velocity/speed output	26
7	Data transfer modes for Profibus	27
7.1	Configuring and parameterizing the encoder	27
7.1.1	DDL_M_Set_Prm - Mode for Class 1 and Class 2	27
7.1.2	DDL_M_SET_PRM mode for HUEBNER 2.1 and HUEBNER 2.2	28
7.2	Commissioning mode	31
7.2.1	Accept preset value	32
7.2.2	Set count direction (code sequence)	32
7.2.3	Scaling the encoder with the teach-in method	33
8	Diagnostic messages	34
9	Faults	35
9.1	Fault table absolute part	35
9.2	LED display for error and status messages	36
10	Inspections	37
10.1	Safety instructions personnel	37
11	Disposal	37
11.1	Disposal procedure	37
12	Dimension drawings	38
12.1	Construction type B5 (flange)	38
12.2	Construction type B35 (flange and foot)	41
13	Dismantling	44
13.1	Safety instructions	44
13.2	Dismantling the encoder	44

1 General

1.1 Information about the Operating and Assembly instructions

These Operating and Assembly Instructions provide important instructions for working with the device. They must be carefully read prior to starting all tasks, and the instructions contained herein must be followed. In addition, applicable local regulations for the prevention of industrial accidents and general safety regulations must be complied with.

1.2 Scope of delivery

Absolute Encoder, Operating and Assembly Instructions.

1.3 Explanation of symbols

Warnings are indicated by symbols in these Operating and Assembly Instructions. The warnings are introduced by signal words that express the scope of the hazard.

The warnings must be strictly heeded; you must act prudently to prevent accidents, personal injury, and property damage.



WARNING!

Indicates a possibly dangerous situation that can result in death or serious injury if it is not avoided.



CAUTION!

Indicates a possibly dangerous situation that can result in minor injury if it is not avoided.



CAUTION!

Indicates a possibly dangerous situation that can result in material damage if it is not avoided.



NOTES!

Indicates useful tips and recommendations as well as information for efficient and trouble-free operation.



NOTES!

Do not use a hammer or similar tool when installing the device due to the risk of damage occurring to the bearings or coupling!



DANGER!

Life-threatening danger due to electric shock!

Indicates a life-threatening situation due to electric shock. If the safety instructions are not complied with there is danger of serious injury or death. The work that must be executed should only be performed by a qualified electrician.

1.4 Disclaimer

All information and instructions in these Operating and Assembly Instructions have been provided under due consideration of applicable guidelines, as well as our many years of experience.

The manufacturer assumes no liability for damages due to:

- Failure to follow the instructions in the Operating and Assembly Instructions
- Non-intended use
- Deployment of untrained personnel
- Opening of the device or conversions of the device

In all other aspects the obligations agreed in the delivery contract as well as the delivery conditions of the manufacturer apply.

1.5 Copyright



NOTES!

Content information, text, drawings, graphics, and other representations are protected by copyright and are subject to commercial property rights.

It is strictly forbidden to make copies of any kind or by any means for any purpose other than in conjunction with using the device without the prior written agreement of the manufacturer. Any copyright infringements will be prosecuted.

1.6 Guarantee terms

The guarantee terms are provided in the manufacturer's terms and conditions.

1.7 Customer service

For technical information personnel is available that can be contacted by telephone, fax or email. See manufacturer's address on page 2.

2 Safety



DANGER!

This section provides an overview of all the important safety aspects that ensure protection of personnel, as well as safe and trouble-free device operation.

If these safety instructions are not complied with significant hazard can occur.

2.1 Responsibility of the owner

The device is used in commercial applications. Consequently the owner of the device is subject to the legal occupational safety obligations and subject to the safety, accident prevention and environmental protection regulations that are applicable for the device's area of implementation.

2.2 Intended use

The device has been designed and constructed exclusively for the intended use described here.

Series AMP Absolute Encoders are used for measurement of rotations, for instance of electrical and mechanical drives and shafts.

Claims of any type due to damage arising from non-intended use are excluded; the owner bears sole responsibility for non-intended use.

For UL and CSA: For the use in NFPA 79 applications only.

2.3 Non- intended use

	<p>Warning: This device is not intended for use in residential areas and cannot ensure adequate protection of radio reception in such environments.</p>
---	--

Do not use the device in potentially explosive areas.

The device must not be subjected to mechanical loads in addition to its own weight and unavoidable vibration and shock loads that arise during normal operations.

Examples for non-permitted mechanical loads (incomplete list):

- Fastening transport or lifting tackle to the device, for example a crane hook to lift a motor.
- Fastening packaging components to the device, for example ratchet straps, tarpaulins etc.
- Using the device as a step, for example by people to climb onto a motor.

2.4 Personnel

Only skilled technical staff is allowed to perform installation, mounting, disassembly and commissioning work.

2.5 Personal protective equipment

For tasks such as assembly, disassembly or commissioning the use of personal protective equipment such as safety footwear and protective work clothing is required.

The regulations specified by the owner and that are locally specified apply.

2.6 Special dangers

Residual risks that have been determined based on a risk assessment are cited below.

2.6.1 Electrical current



DANGER!

Life-threatening danger due to electrical shock!

There is an imminent life-threatening hazard if live parts are touched. Damage to insulation or to specific components can pose a life-threatening hazard.

Therefore:

Immediately switch off the device and have it repaired if there is damage to the insulation of the power supply.

De-energize the electrical equipment and ensure that all components are connected for all tasks on the electrical equipment.

Keep moisture away from live parts. Moisture can cause short circuits.

2.6.2 Rotating shafts / hot surfaces



WARNING!

Danger of injury due to rotating shafts!

Touching rotating shafts can cause serious injuries.

Therefore:

Do not reach into moving parts/shafts or handle moving parts/shafts during operation. Close to protect from injury all access openings in flanges with the corresponding plug screw, and provided you exposed rotating components with protective covers.

Do not open covers during operation. Prior to opening the covers ensure that all parts have come to a standstill.

The encoder can become hot during prolonged use.

In case of contact risk of burns is existing.

2.6.3 Safeguarding against restart



DANGER!

Life-threatening danger if restarted without authorization!

When correcting faults there is danger of the power supply being switched on without authorization.

This poses a life-threatening hazard for persons in the danger zone.

Therefore:

Prior to starting work, switch off the system and safeguard it from being switched on again.

3 Technical Data

3.1 Type plate

Type plate example

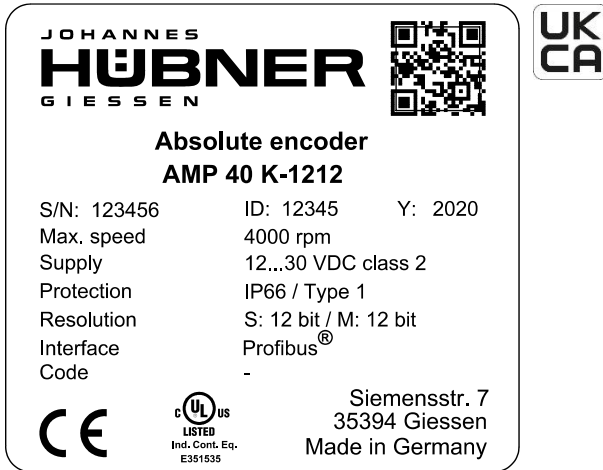

The nameplate and UKCA label are located on the side of the housing.

Nameplate-information:

- Manufacturer, Address
- Type, Year of construction
- CE marking
- Serial number (S/N)
- Resolution singleturn 12 bit / multiturn 12 bit
- Power supply
- Degree of protection (IP66)
- Max. speed
- Interface
- Code
- Certification
- QR-Code

3.2 Type code

	AMP	40	KK	12 12
Absolute encoder				
Series				
Connections				
K: 1 Terminal box				
KK: 2 Terminal boxes (redundant version)				
Resolution				
Singleturn 12 bit				
Multiturn 12 bit				

3.3 Electrical and mechanical data

Type	AMP 40 K-1212			
Supply voltage	12 V ... 30 V DC			
Resolution Singleturn	max. 12 bit (4096 steps per revolution)			
Resolution Multiturn	max. 12 bit (4096 revolutions)			
Supply current	140 mA (+24V)			
Data interface	RS 485 electrically isolated from encoder electronic			
Baud rate	(12-6-3-1,5) Mbaud (500-187,5-93,75-19,2-9,6) kbaud			
Device address	adjustable 0 -99			
Bus termination	switchable			
Coding	binär			
Programmable functions				
Multiturn or Singleturn				
CLASS 1 Mode	Counting direction			
CLASS 2 Mode	Counting direction Resolution/revolution Resolution Scaling			
Mode 2.1	CLASS 2 mode additional end switch function			
Mode 2.2	CLASS 2 mode additional end switch function and velocity output			
Protection class acc. to DIN EN 60529	Sealing	Permissible speed	Rotor moment of inertia	Breakaway torque
IP66	with labyrinth seal	$\leq 6000 \text{ min}^{-1}$	580 gcm ²	6 Ncm
IP66/IP67	with axial shaft seal	$\leq 4000 \text{ min}^{-1}$	510 gcm ²	8 Ncm
IP66/IP67	with radial shaft seal (for special applications, e.g. wet areas in rolling mills)	$\leq 3000 \text{ min}^{-1}$	510 gcm ²	9 Ncm
Vibration resistance	DIN EN 60068-2-6 / IEC 68-2-6 (10 ... 2000 Hz)			20 g (=200 m/s ²)
Shock resistance	DIN EN 60068-2-27 / IEC 68-2-27 (6 ms)			150 g (=1500 m/s ²)
Max. encoder shaft load	F _{a, max.} (axial) = 100 N F _{r, max.} (radial) = 120 N			
Shaft dimensions	11j6 x 30 mm (standard) 14j6 x 30 mm (optional)			
Weight	Type KK (construction type B5)			approx. 4 kg
Temperature range	-25 ... +85 °C		For UL and CSA: -25 ... +70 °C	

The AMP 40 is categorised in Group 1 and Class A in accordance with EN 55011 and is only intended for use in an industrial environment.

4 Transport, packaging and storage

4.1 Safety instructions for transport

	<p>CAUTION! Material damage caused by improper transport! Observe the symbols and information on the packaging: Do not throw - risk of breakage Keep dry Do not expose to heat above 40 °C or direct sunlight.</p>
---	---

4.2 Incoming goods inspection

Check the delivery immediately upon receipt for transit damage or short delivery. Inform the carrier immediately on receipt if you determine that damage has occurred during transit (take photos as proof).

4.3 Packaging / disposal

The packaging is not taken back and must be disposed of in accordance with the respective statutory regulations and local guidelines.

4.4 Storage of packages (devices)

	<p>Keep dry! Keep packages dry and free from dust; protect from moisture.</p>
---	---

	<p>Protect against heat! Protect packages from heat above 40 °C and direct sunlight.</p>
---	--

If you intend to store the device for a longer period of time (> 6 months) we recommend you use protective packaging (with desiccant).

	<p>NOTES! Turn the encoder shaft every 6 month to prevent the bearing grease solidifying!</p>
---	---

5 Installation and commissioning

5.1 Safety instructions



NOTES!

Observe the safety instructions contained in **Chapter 2** when installing or working on the device!

Personnel

Installation and commissioning must be carried out by skilled technical staff only.

5.2 Technical information



NOTES!

Do not use a hammer or similar tool when installing the device due to the risk of damage occurring to the bearings or coupling!

Ambient temperature

The max. permissible ambient temperature depends on the speed and degree of protection of the device, the signal frequency, the length of the signal cable and the place of installation (please refer to Chapter 3.3).

Degree of protection

To fulfil degree of protection requirements the diameter of the connection cable must correspond to that of the cable gland (please refer to Chapter 12 dimension drawings)!

Deep groove ball bearings

Absolute encoders AMP 40 are fitted with maintenance-free, greased "for-life" deep groove bearings. Bearings must be changed by the manufacturer only. Opening the encoder renders the guarantee null and void.

Screw retention

We recommend using Loctite® 243 threadlocker (medium strength) on all fastening screws to prevent loosening.

5.3 Required tools

- Spanners: 10 mm, 17 mm, 22 mm
- Allen keys: 2 mm, 3 mm
- Flat-blade screwdrivers:
- Assembly grease
- Loctite® 243 (medium strength threadlocker)

5.4 Mounting preparations

1. Ensure all accessories are available (please refer to Chapter 12 Dimension drawings).



NOTES!

Fastening screws and earth cable are not included in the range of supply.

2. Preparing the place of attachment: Clean the (motor) shaft, centering, bolting surfaces and fastening threads; check for damage. Repair any damage!

5.5 Mounting B5 type (flange) encoders



NOTES!

For a mounting example please refer to dimension drawing HM 16 M 110210 (Chapter 12.1).

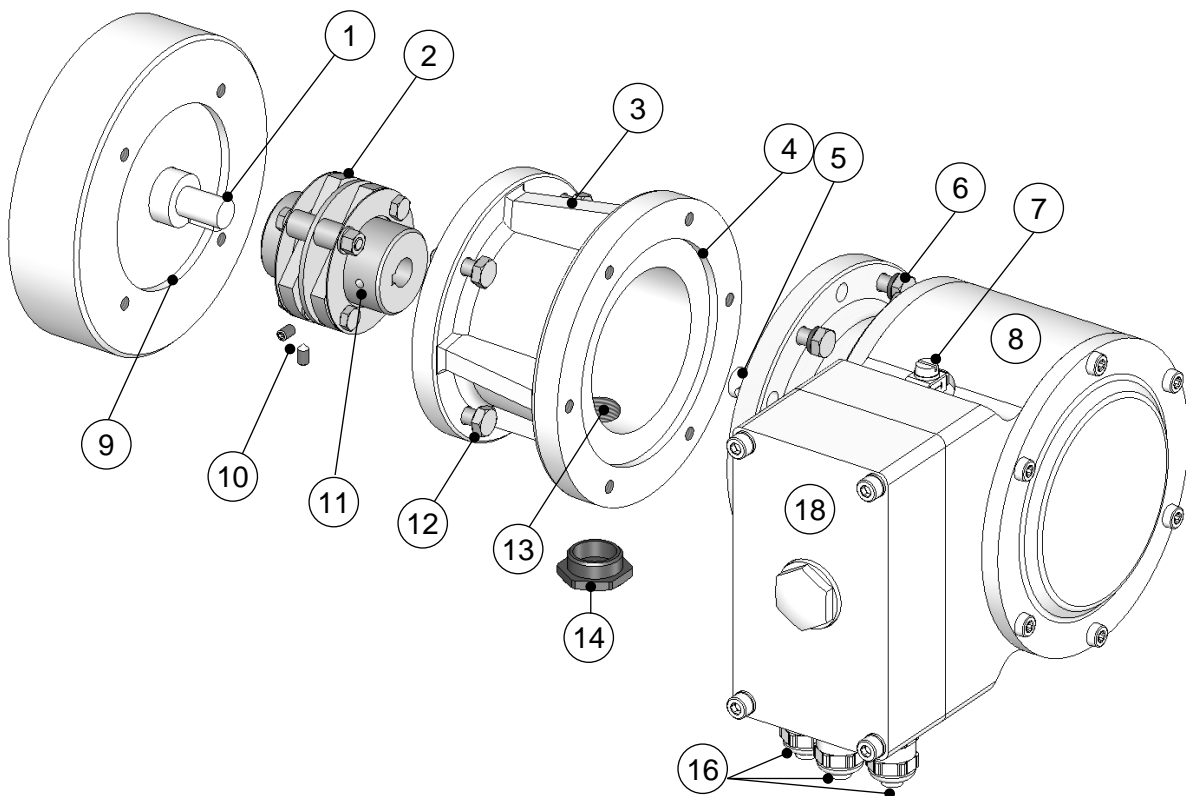

Figure 1: AMP 40 K construction type B5

1. Lightly grease the (motor) shaft (1) and centering (9).
2. Mount coupling (2) onto (motor) shaft.

**NOTES!**

You must be able to mount the coupling without force. Ream out the bores of used couplings, if necessary!

3. Secure the coupling hub on the (motor) shaft with a grub screw or cheese head screw (10) (depending on the coupling type).
4. Fasten the intermediate flange (3) to the motor using the fastening screws (12).

**NOTES!**

If possible, mount the intermediate flange in a manner that ensures the screwed sealing plug (14) points downwards!

5. Lightly grease the encoder shaft (5) and centering (4).
6. Mount the encoder (8) into both the centering (4) and coupling hub at the same time.

**NOTES!**

If possible, fit the device in a manner that ensures the cable glands (16 + 17) points downwards.

7. Secure the encoder with 4-6 screws (6) evenly distributed around the circumference of the flange.
8. Remove the sealing plug (14) from the access bore (13) to the coupling.
9. Secure the coupling hub on the encoder shaft with a grub screw or cheese head screw (11) (depending on the coupling type).

**NOTES!**

To carry out this task, it may be necessary to turn the (motor) shaft to the correct position.

10. Replace the sealing plug (14) to seal the access bore to the coupling.
11. If necessary, a ground wire can be connected to the protective conductor terminal (7).

5.6 Mounting B35 type (flange and foot) absolute encoders



NOTES!

B35 type encoders can be attached by means of a flange (B5, please refer to Chapter 5.5) or foot (B3):

For a mounting example please refer to dimension drawing HM 16 M 110209 (Chapter 12.2).

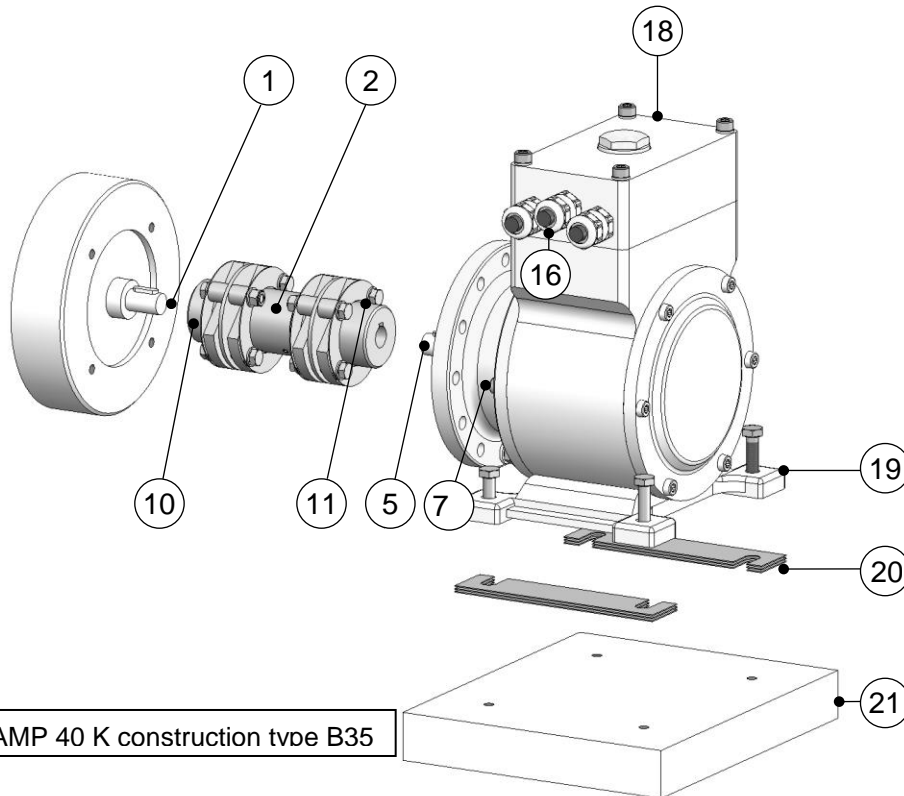

Figure 2: AMP 40 K construction type B35

1. Grease lightly the (motor) shaft (1).
2. Mount coupling (2) onto (motor) shaft.



NOTES!

You must be able to mount the coupling without force. Ream out the bores of used couplings, if necessary!



NOTES!

We recommend our zero-backlash, torsion-resistant **double-joint coupling HKD5** to attach B35 type encoders. Please refer to the catalogue *Torsion Resistant Couplings for Encoders*.

3. Secure the coupling hub on the (motor) shaft with a grub screw or cheese head screw (10) (depending on the coupling type).

4. Align the encoder shaft (5) to the (motor) shaft and insert into the coupling hub.



NOTES!

Use shims (20) to achieve the correct vertical alignment to the base plate (21).
Observe information in Chapter 5.7 about mounting errors and max. permissible mounting tolerances!

5. Fasten encoder foot with 4 M6 hexagon head screws (19).

6. Secure the coupling hub on the encoder shaft with the grub screw or cheese head screw (11) (depending on the coupling type).



NOTES!

To avoid injuries by turning parts, the coupling must be provided before introduction with a suitable cover.

5.7 Mounting tolerances for construction type B5 and B35



NOTES!

Angle misalignment and parallel displacement between the (motor) shaft and the encoder shaft are mounting errors and should be kept as small as possible.

Mounting errors

- Cause radial forces to act on the encoder shaft.
- Reduce the service life of the bearings and the coupling.
- Degrade the quality of the signals (harmonic content).

Mounting tolerances for our zero-backlash, torsion-resistant couplings HK5 and HKD5:

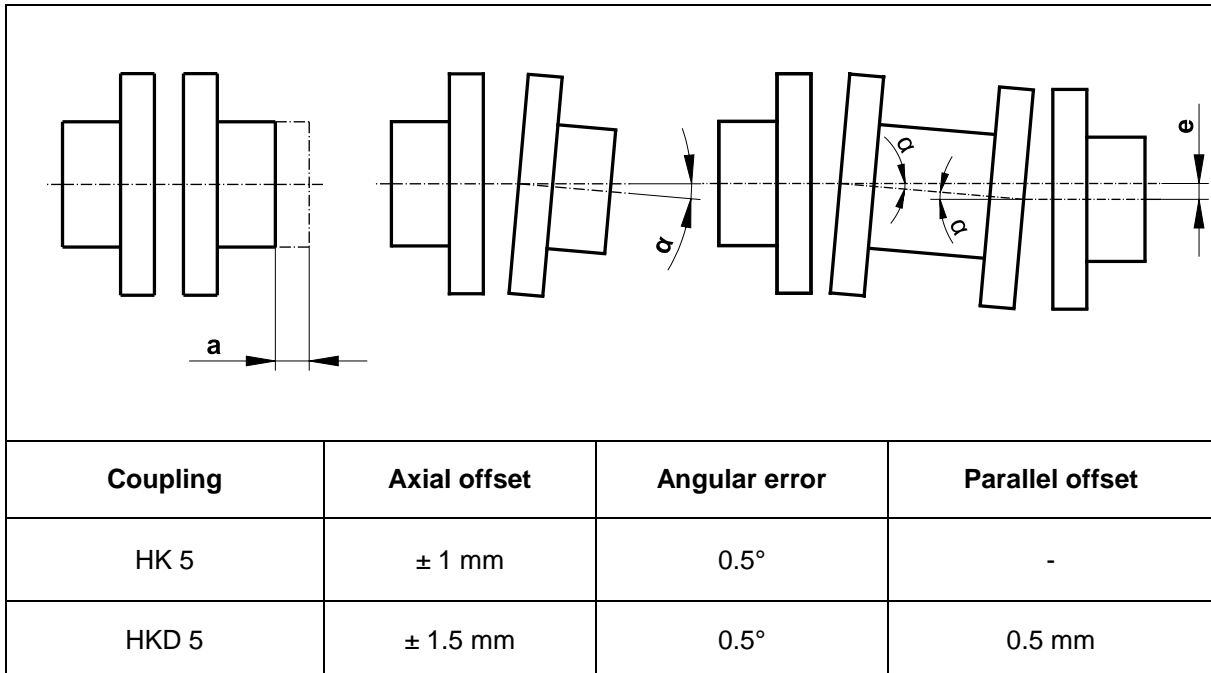

5.8 Installation

5.8.1 General rules

NOTES!

In environments with high drive power, external systems can generate high electromagnetic emissions. Adverse effects on AMP 40 operation can be avoided by observing the following guidelines:

- Uninterrupted, low-resistance machine grounding must be ensured across all parts of a plant. Ensure that the connections have good electrical contact. Poor conductivity can be caused, for example, by paint, lubricants, corrosion or similar. In practice, large cable cross-sections are required for low-resistance machine grounding.
- Generous mounting distances must be maintained from actuators with a high energy density, such as contactors, inverters, motors, solenoid valves and brakes.
- Shielding of cables must be carried out professionally, for example between the inverter and motor. Please observe the manufacturer's specifications.
- Inductances of relays, contactors, solenoid valves or brakes should be wired with suppressors. To prevent conducted interference coupling, this is necessary for relays or contactors that are connected directly to the inputs or outputs (IO). To prevent interference coupling via the air path, this also applies to all inductances in the near field of the installation. Suppressors must be connected directly to the coil: RC elements or varistors for operation with alternating current (AC) and freewheeling diodes or varistors for operation with direct current (DC), whereby freewheeling diodes are preferable.
- The AMP 40 is operated with low voltage of up to 30 V. To avoid interference coupling via the air path, it is important to plan cable routes with sufficient distance to power lines in accordance with the following diagram. This generally applicable diagram is to be used for all connections **inside** and **outside** control cabinets.

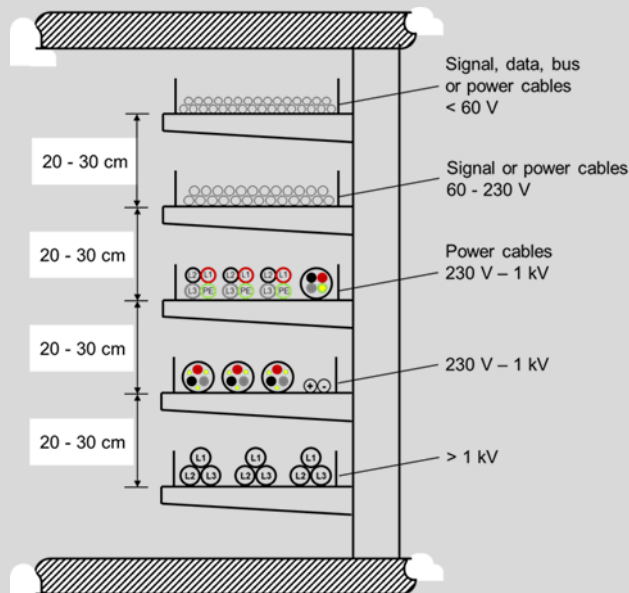

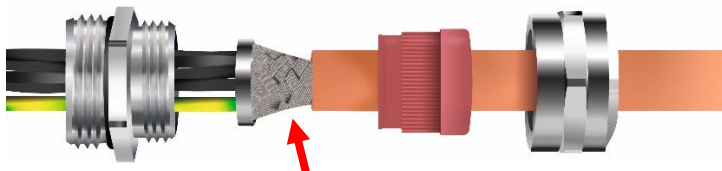

Figure 1: Scheme for planning cable routes

5.8.2 Connecting

	<ul style="list-style-type: none"> • Sufficient dimensioning of the power supply. • The conductor cross-section of the power supply cable must be designed so that the maximum voltage drop is less than 3 V. A wire cross-section of 0.75 mm² is recommended. Permissible cable diameter: 6,5...9,5 mm. (Cable diameter for UL-listed devices 8...9,5 mm). • A DC distribution network can comprise considerable cable lengths, which may be subject to interference. It is recommended that the AMP 40 is not operated on a heavily disturbed DC distribution network. If necessary, a separate power supply should be provided. To minimize interference, the DC distribution should be connected to the power supply unit in a star configuration and with symmetrical routing of the forward and return conductors (as a “twisted pair” or as a cable). • A shielded supply cable must be used for the electrical connection. The cable shield must be connected to the machine grounding on both sides. Shield connection terminals must be used to connect the cable shielding to a large surface area in the switch cabinet. The same applies to the shielding of signal cables. • A cable for connecting to ground potential must be connected to the ground terminal of the AMP 40, if not already pre-assembled (max. tightening torque 2.0 Nm). • A flat grounding strap consisting of fine stranded wire with a minimum cross-section of 6 mm² must be used for grounding. • The grounding strap must be permanently and permanently connected to a low-impedance, nearby grounding point on the system side. The grounding point must be bare metal, free of paint, non-conductive surface finishes, grease, oil and corrosion. The length of the grounding strap should not exceed 2 m.
---	---

5.8.3 Shield contacting for EMC cable gland with cone



Example –Figure: Cable gland with cone

The shield is placed on the cone. The insulation must be removed at this point. The shielding must remain intact in this area and must not be damaged.

5.8.4 Work steps for bus cover connection

1. Strip the supply cable. Suitable tools must be used to strip the insulation. The cable for the supply cable is shielded. The conductor cross-section must be at least 0.75 mm² and the cable diameter at least 6.5 mm. The cable for fiber optics does not have a shield.
2. Crimp on the wire end ferrules.
3. Strip the PROFINET cable. Suitable tools must be used for stripping.
4. Crimp on wire end ferrules depending on the cable type.
5. Open the terminal box cover.
6. Remove the locking bolts from the cable glands. The cable glands are EMC cable glands.
7. Feed the cable through the cable glands into the terminal box.
8. The shielding of the cables is connected directly to the housing via the EMC cable glands with a cone contact.
9. Tighten the cable glands until the cables are securely clamped and sealed.

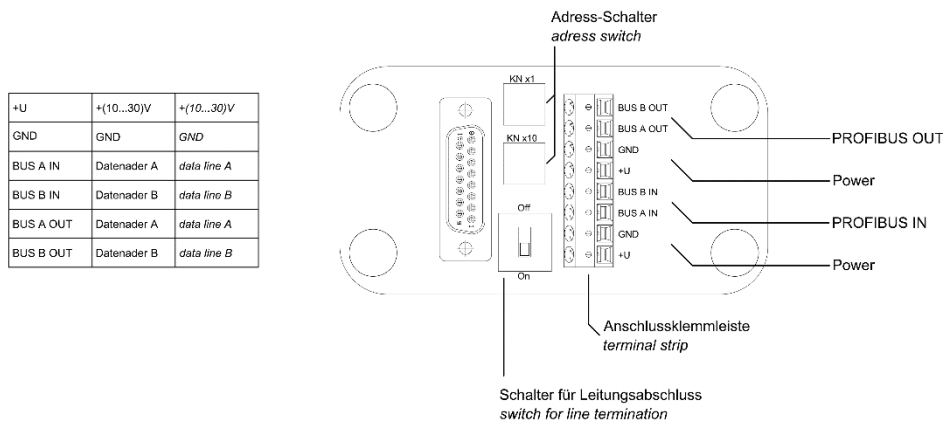

Connection diagram
PN 179-400a



NOTES!

- Observe the connection diagram.
- When the terminal box cover is open, moisture must not get into the terminal box.
- Avoid lateral tensile forces on cables so as not to impair the degree of protection of the cable gland.

The cable connection will be done in the detachable terminal box from the device. With encoder's change the interwirings, as well as the settings of device address and management connection are preserved.



Special note!

Qualified personnel may only connect the encoder.

Set up the device address:

Setting the device address has to be done in the address switches. The address can be selected from 1 to 99. If the encoder is the last device on the bus, then the switch for the bus/line termination must be set to the ON position. In other cases, this switch must be set to the OFF position.

Close the terminal box cover:

Before closing the terminal box cover check and if necessary clean both seal surfaces and the gasket. Then close the terminal box cover properly.



cables must not become jammed
Caution when the terminal box cover is open:
 During the connection of the connection cable no humidity may reach in the terminal box.



NOTES for UL and CSA!
 Do only use copper cables.

5.8.5 Technical information

Ambient temperature

The max. permissible ambient temperature depends on the speed and degree of protection of the device, the signal frequency, the length of the signal cable and the place of installation (please refer to Chapter 3.3).

5.9 Maintenance information

The device is maintenance-free. However, to guarantee optimum fault-free operations we recommend that you carry out the following inspections.

5.10 Inspection schedule

Interval	Inspections
Yearly	Inspect the coupling for damage and ensure it is free of play
	Ensure the fastening screws are properly tightened
	Ensure cable connections and connection terminals are properly tightened
After approx. 16 000 – 20 000 hours of operation or higher levels of continuous load	Check deep groove ball bearings for noise, running smoothly.

6 Installation and commissioning

6.1 User manual

The instrument can be used as a multiturn or singleturn absolute encoder. It can be configured to the Profibus® profiles CLASS 1 (Huebner 1.0), with parameterization of the count direction, or CLASS 2 (Huebner 2.0), with the additional setting of the resolution in units/turn and the total measuring range.

The profiles Huebner 2.1 and Huebner 2.2 are also available. These enable the following additional functions:

- Expanded scaling function
- Setting of code sequence (count direction), preset and automatic scaling (teach-in) during online operation in commissioning mode.
- Limit switch function
- Velocity/speed output

These functions shift a portion of the computing effort from the Profibus master to the absolute encoder, thus reducing the load on the system as a whole. However, if these extra functions are not needed, then it makes sense to keep the parameterization simple, by using a CLASS 1 or CLASS 2 profile.

6.2 Profibus profile for the absolute encoder

The AMP 40 absolute encoder is a multiturn encoder that has been designed to operate with Profibus®. It can be configured and parameterized to the following profiles, as a multiturn or singleturn encoder:

Absolute encoder profile	Parameterization options
HUEBNER 1.0 Single / Multiturn (CLASS 1)	Count direction (code sequence)
HUEBNER 2.0 Single / Multiturn (CLASS 2)	Count direction (code sequence) Switch HUEBNER 2.0 functions on/off Switch scaling functions on/off Resolution in units/revolution Total measuring range
HUEBNER 2.1 Single / Multiturn	As for HUEBNER 2.0, additionally with: Required no. of measuring units, Required resolution in units per <ul style="list-style-type: none"> - revolution - max. total measuring range - physical pulses Switch commissioning mode on/off Use preset value in online operation Change count direction (code sequence) in online operation Determine gearing factor (scaling) Switch lower limit switch on/off Lower limit switch (position) Switch upper limit switch on/off Upper limit switch (position)
HUEBNER 2:2 Single / Multiturn	As for HUEBNER 2.1, with additional velocity/speed output

Note:

The encoder can be operated in HUEBNER 1.0, HUEBNER 2.0, HUEBNER 2.1 or HUEBNER 2.2, regardless of whether a CLASS 1 or CLASS 2 master has been selected.

6.3 Joining the encoder to the Profibus

After the encoder has been installed and the electrical connections have been made, it is joined to the Profibus system. The following is an example, using the COM PROFIBUS V 5.0 installation software with an IM308C Profibus-DP master.

First of all, the manufacturer-specific bitmap files (*.bmp, *.dib) are copied to the bitmaps directory, and the GSD file is copied to the GSD directory of the COM PROFIBUS software. Next, start the COM PROFIBUS installation software. In the FILE menu, create a new configuration file in the menu item NEW, or use the menu item OPEN to call up an existing configuration file. The GSD file is now read in, using the menu item READ GSD FILES.

In the selection list, under DP Master, select the type IM308C, and under DP Slave / Encoder, select the HUEBNER encoder AMP1212, and place them in the bus graphic in the right window with a double click.

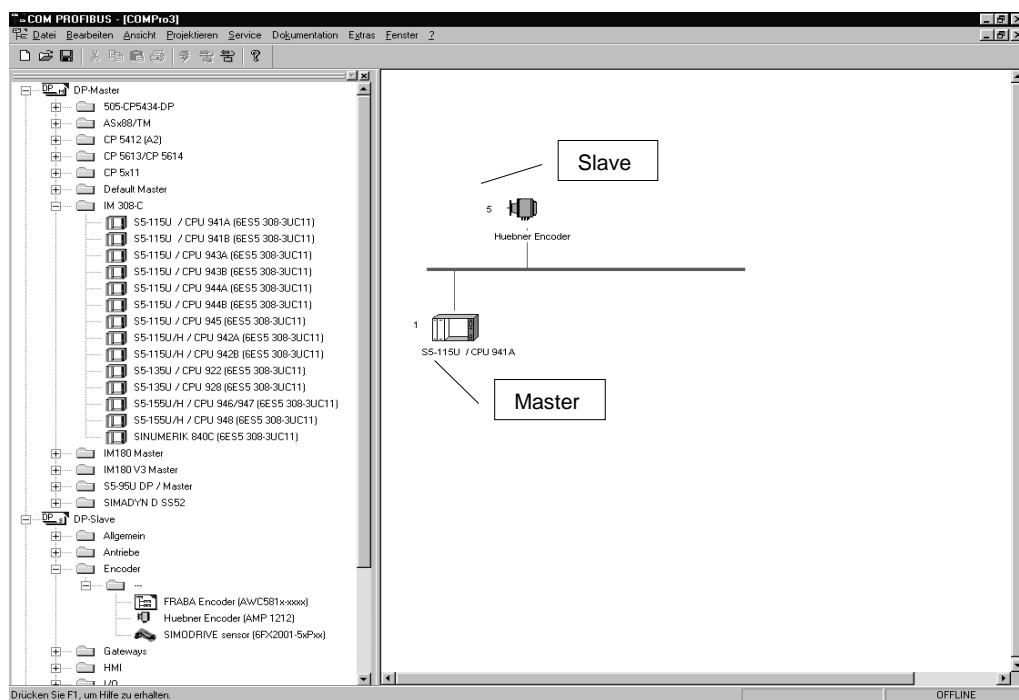

By selecting the menu item CONFIGURE / DP SLAVE CONFIGURE, or by clicking with the mouse pointer on the encoder icon, you can access the *Slave properties* window. The bus address of the encoder must be entered here, to match the setting of the address selector switches in the terminal box of the encoder.

Then continue with the *Configure* menu.

6.4 Configuring the encoder

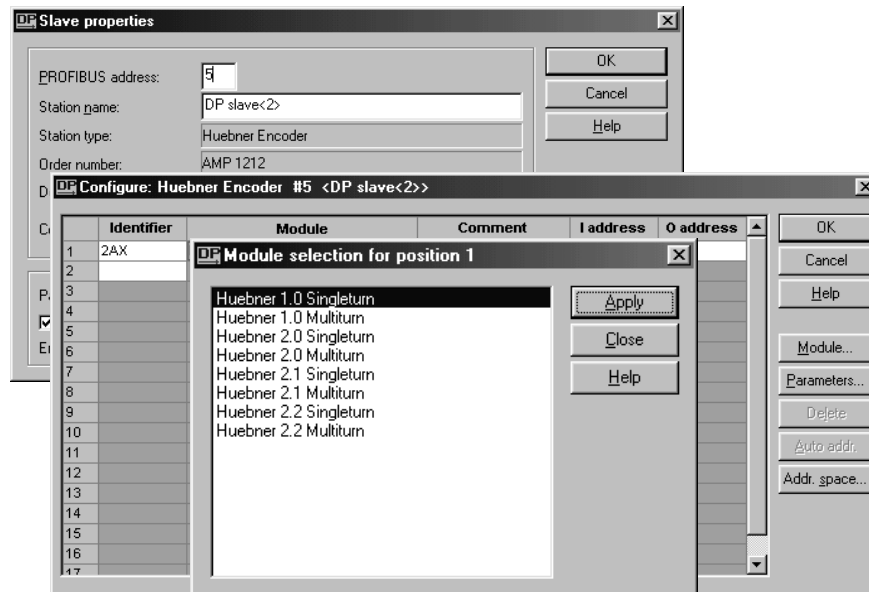

Now select the profile for the encoder operation. The input and output address are then assigned, and the parameterization can be carried out. This function can be called up by the PARAMETERS button in the CONFIGURE window, and provides a clear and simple way of setting the parameters. Parameterization through other windows has to be performed in hexadecimal format, an operation which demands precise knowledge of the significance of the individual bits and bytes.

6.5 Parameterizing the encoder

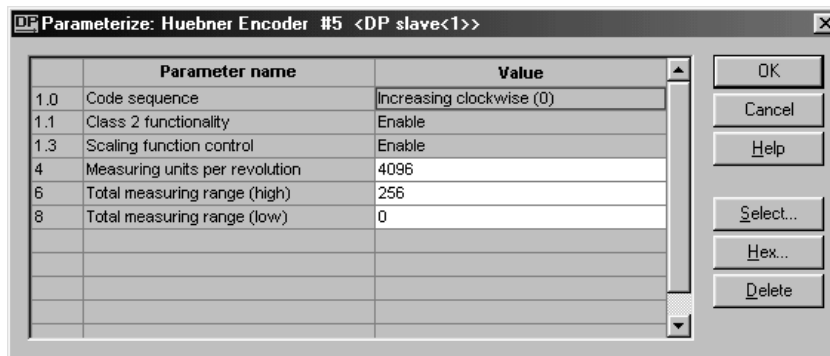

In this example, the PARAMETERIZE window shows the options for setting the parameters for an absolute encoder that has been configured for HUEBNER 2.0.

Note:

If Class 2 functionality is switched off, then the encoder operates in the HUEBNER 1.0 mode. The only option available is to change the count direction (code sequence). The resolution in units per revolution can have any value from 1 to 4096, and this determines the size of the unit. The total measuring range defines the measurement path length as the number of revolutions with the given resolution (units per revolution) until the zero position is reached again.



NOTE!

Total measuring range = units per revolution x number of revolutions
 The number of revolutions must have a value 2^n , where n can be from 1 to 12

If this is not taken into account, the encoder will detect a parameter error. This is indicated on the cover of the terminal box. The red LED lights continuously, while the green one blinks.



NOTE!

To activate the parameterization of Measuring units per revolution, Class 2 functionality and the scaling function must be switched on. The preset value then has to be reset in the normal operating mode, since it is referred to the scaled value.

6.6 Parameterization in hex code

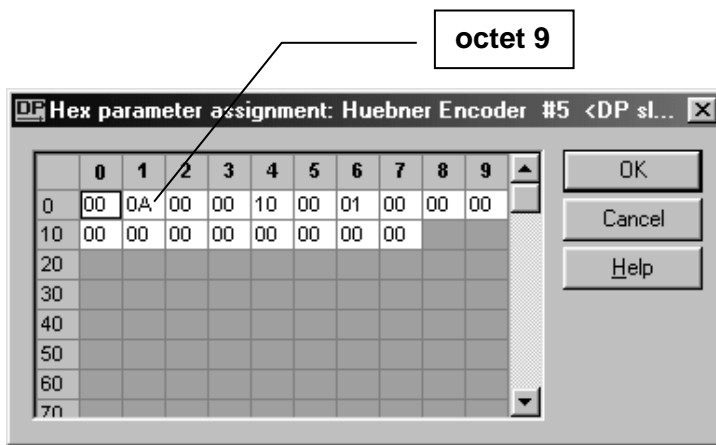

It is also possible to carry out the parameterization in the *Hex parameter assignment* window. However, this is an awkward operation, requiring precise knowledge of the functions of the individual bits and bytes.

6.7 Operating the encoder in the Huebner 2.1 and Huebner 2.2 profiles

Compared with the standard profiles, these two profiles offer several additional functions which can be parameterized through COM Profibus®, as is explained below.

The SCALING function must be activated as a precondition for using these additional functions.

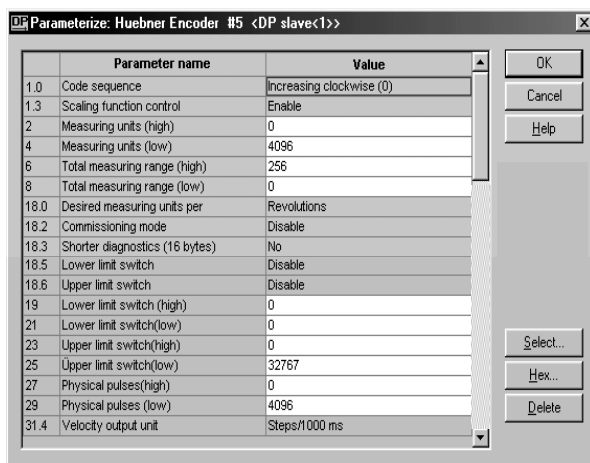

6.8 Desired measuring units per...

Compared with the HUEBNER 2.0 (CLASS 2) profile, three different scaling options are available.

Required resolution: units per revolution
max. total measuring range
physical pulse

6.8.1 Desired measuring units per revolution

Here you can define the number of units that the encoder produces per revolution. In addition, the total possible path length for measurement, and thus the number of revolutions, is defined in the fields for the total measuring range.

Example:

The required value is 8 units per revolution. The total measuring range should cover 8 revolutions, or repeat after 8 revolutions. This requires

$$8 \times 8 = 64$$

units. So 8 units must be entered for DESIRED MEASURING UNITS, and 64 units for TOTAL MEASURING RANGE.



CAUTION!

The number of revolutions must have a value of 2^n where n can be from 1 to 12. If this is not observed ambiguous position values will occur, since the transition from the maximum encoder position to the 0 position value will happen at various encoder positions.

6.8.2 Desired measuring units per maximum total measuring range

For this type of scaling, the maximum possible measuring range of the encoder is divided into a definite number of units. This number is then entered in the fields for Desired measuring units per.

Example:

The entire measuring range of the encoder is to be divided into 16384 units.

$$16384 / 4096 = 4 \text{ units per revolution}$$

The number of units that are required must be smaller than the number for the total measuring range. This type of scaling is also used in commissioning mode, for automatic scaling (teach-in).

6.8.3 Desired measuring units per physical pulse

This setting is always referred to the division of the code disk into 4096 pulse intervals. The number that is entered in the entry fields for MEASURING UNITS is the number of parts into which the value entered for PHYSICAL PULSES is to be divided.

Example:

Physical measurement pulses = 2048, required number of measuring units = 64

$$2048 / 64 = 32$$

So the required measurement unit has a length of 32 physical intervals (pulses).



CAUTION!

This value must divide into the total measuring range 2^n times. If this is not observed, ambiguous position values will occur, since the transition from the maximum encoder position to the zero position (0) will happen at various encoder positions.

6.9 Commissioning mode

If this mode is activated, then the following functions are available in online operation:

changing the count direction (code sequence)

setting the preset value

automatic scaling (teach-in)

These values are set from the Profibus master, by manipulating the status bit in the DDLM_DATA_EXCHANGE mode. A detailed description is included in a later section.

6.10 Limit switches

Two software limit switches are available, which can be activated through the fields UPPER LIMIT SWITCH and LOWER LIMIT SWITCH. The required positions for the limit switches are referred to the total measuring range that has been selected. They must not lie outside this range, and are entered in the fields UPPER LIMIT SWITCH (HIGH/LOW) and LOWER LIMIT SWITCH (HIGH/LOW).

As long as the encoder is positioned between the two switch positions, the corresponding status bit (bit 27) is set to LOW. If the position goes outside the limits, i.e. above the upper position or below the lower position, the bit is set to HIGH.

6.11 Velocity/speed output

This function can only be used with the HUEBNER 2.2 encoder profile. The following options are available for the output:

units per 1000 milliseconds

units per 100 milliseconds

units per 10 milliseconds

revolutions per minute

7 Data transfer modes for Profibus

Three data transfer modes are needed for operating the encoder on a Profibus:

When the system is started up, the data that are required for configuration and parameterization are transferred in the **DDL_M_SET_PRM** mode from the master to the encoder (attached as a slave). 16 to 39 bytes (octets) are necessary for this operation, depending on the encoder profile.

In the **DDL_M_Data_Exchange** mode, the master requests data from the encoder outputs. If the encoder is configured for Hübner 2.1 or Hübner 2.2, then some parameters can be altered in online operation.

In the **DDL_M_Slave_Diag** mode, the master requests diagnostic data from the encoder.

Normally, the configuration and parameterization in the DDL_M_Set_Prm mode when the system is started up, and the subsequent operation in the DDL_M_DATA_EXCHANGE mode are performed automatically.

The settings for the necessary functions are defined beforehand in the selection menus in the windows of the Profibus system (COMProfibus).

However, in some cases it is necessary to know the relevant commands, so that parameters can also be altered manually.

7.1 Configuring and parameterizing the encoder

The following shows which bits can be set in the DDL_M_SET_PRM mode. Octets 1-8 contain Profibus-specific data, and should not be altered.

7.1.1 DDL_M_Set_Prm - Mode for Class 1 and Class 2

Octet	Parameter	Bit – No.	
	Count direction (code sequence)	0	right = 0, left = 1
	Class 2 functionality	1	off = 0, on = 1
	Commissioning diagnostics	2	not used for AMP1212
	Scaling function	3	off = 0, on = 1
9	Reserved	4	---
	Reserved	5	---
	optional for Hübner 2.1 and 2.2	6	not for Class 1 and Class 2
	Reserved	7	
10 - 13	Resolution: units per revolution	$2^{31} - 2^0$	max. 4096
14 - 17	Total measuring range	$2^{31} - 2^0$	max. 4096 x 4096

In Class 1 operation, only the count direction (code sequence) bit can be altered.

7.1.1.1 Klasse 2 Funktionalität (Octet 9.1)

This bit can be set to 0, to switch over to Class1 operation.

7.1.1.2 Scaling function control (octet 9.3)

If this bit is cleared, the encoder has a resolution of 4096 units per revolution, and a total measuring range of 4096 x 4096 units (corresponding to 4096 revolutions). If bit 3 = 1, then it is possible to make a scaling of the units per revolution and the total measuring range.

7.1.1.3 Resolution: units per revolution (octet 10 – 13)

This value must not be larger than 4096, otherwise the output code will be ambiguous.

7.1.1.4 Total measuring range (octet 14 – 17)

The value that is set here must be an exact multiple of the resolution (in units per revolution), whereby the multiplying factor is the number of revolutions, and can only have a value 2^n (where $1 < n < 12$).



CAUTION!

**Total measuring range = units per revolution x number of revolutions
and number of revolutions = 2^n**

If any other value is used for the number of revolutions, then jumps will occur at the transition from the maximum encoder position to position 0 (zero position), resulting in ambiguous position data.

7.1.2 DDLM_SET_PRM mode for HUEBNER 2.1 and HUEBNER 2.2

The user profiles HUEBNER 2.1 and HUEBNER 2.2 are an extensions of the CLASS 2 profile. They provide additional functions that can be applied by the user. Unused functions can be switched off. This makes it possible to use online parameterization in the **DDLM_DATA_EXCHANGE mode** to set the code sequence (count direction), the preset value, and to determine the gearing factor. Furthermore, HUEBNER 2.2 allows the output of a velocity/speed value.

Bits and bytes for parameterization of HÜBNER 2.1 and HÜBNER 2.2

Octet	Parameter	Bit – Nr.	
	Count direction (code sequence)	0	right = 0, left = 1
	Class 2 functionality	1	off = 0, on = 1
	Commissioning diagnostics	2	---
	Scaling function control	3	off = 0, on = 1
9	Reserved	4	---
	Reserved	5	---
	HUEBNER 2.1 and 2.2	6	off = 0, on = 1
	Reserved	7	
10-13	Units per xxx	$2^{31} - 2^0$	see Octet 26 / bit1+0
14-17	Total measuring range		
18-25	Reserved for encoder profile		
	Measuring units	1 + 0	00H per revolution 01H per total measuring range 10H physical pulse intervals
	Commissioning mode	2	off = 0, on = 1
	Shorter diagnostics	3	off = 0, on = 1
26	Reserved	4	---
	Lower limit switch active	5	off = 0, on = 1
	Upper limit switch active	6	off = 0, on = 1
	Octet 27 – 39 active	7	off = 0, on = 1
27-30	Lower limit switch	$2^{31} - 2^0$	
31-34	Upper limit switch	$2^{31} - 2^0$	
35-38	Physical pulses	$2^{31} - 2^0$	
	Reserved	0	---
	Singleturn/Multiturn	1	single-turn = 0, multi-turn = 1
	Reserved	2	---
39	Reserved	3	---
	Velocity/speed dimension unit	5 + 4	00H units/second 01H units/100 msec 01H units/10 msec 11H rpm
	Reserved	6	---
	Reserved	7	---

7.1.2.1 HUEBNER 2.1 and 2.2 (octet 9.6)

This bit is used to enable the other encoder functions which are available in this profile (in octet 26).

7.1.2.2 Measuring units per xxx (octet 10 – 13) + required measuring units (octet 26.0 and 26.1)

The bits for the desired measuring units (octet 26.0 and 26.1) can be used to store a value in octet 10 – 13 that refers to the following ranges:

- measuring units per revolution
- measuring units, referred to the total measuring range
- physical pulses

For measuring units per revolution (octet 26.0 and 26.1, 00H)

This entry refers to one revolution of the encoder, and defines the number of units into which this single revolution is divided. Values up to 4096 can be entered. Taken together with the value for resolution referred to total measuring, as stored in octet 14 – 17, this defines the measuring range of the encoder, (see also under Total measuring range)

For measuring units referred to the total measuring range (octet 26.0 and 26.1, 00H)

This entry defines the number of measuring units over 4096 revolutions, so it is referred to the total measuring range of the encoder.

For physical pulses (i.e. physical measuring intervals) (octet 26.0 and 26.1, 00H)

The resolution is the same as the code disk, with 4096 intervals. Depending on the value for the total measuring range, the number of revolutions is a number of $2n$ with $1 < n < 12$ (see also under Total measuring range). In this mode it is possible to scale the measuring range that is defined.

To do this, the number of units into which the total measuring range is to be divided is entered in the octets 35 to 39. In addition to the direct entry, the scaling can also be determined by the teach-in method.

7.1.2.3 Commissioning mode (octet 26.2)

This switch is used to set a special status in the DDLM_SET_PRM mode, where (in a system that is ready for operation) the preset value and other parameters are transferred to the encoder, and stored there in non-volatile memory. A gearing factor can also be determined in this mode. The parameters that are established in this way should be recorded, so that they can be transferred to the encoder when the bus system is started up again in DDLM_SET_PARA mode and the commissioning mode is switched off.

7.1.2.4 Shorter diagnostics (octet 26.4)

Many (mostly older) Profibus masters cannot read in all the diagnostics bytes from the encoder. (Refer to the documentation for the master which is used.) If this bit is set, then only 16 diagnostics bytes are transferred.

7.1.2.5 Octet 27 – 39 active (octet 26.7)

When this bit is set, access is enabled to octets 27 to 39.

This enables the functions: upper and lower limit switches, scaling through physical pulses, Singleturn/Multiturn, and the dimension for the velocity/speed (only for HUEBNER 2.2).

7.1.2.6 Lower / upper software limit switches (octet 26.5 and 26.6) and (octet 27 – 34)

Setting these bits activates the lower software limit switch (octet 26.5) and the upper limit switch (octet 26.6). The position values which are required are stored in octet 27 – 30 (for the lower limit) and octet 31 – 34 (for the upper limit). This function can only be used for programming the classes HUEBNER 2.1 and 2.2.

7.1.2.7 Physical measurement pulses (octet 35 – 38)

The number of physical measuring pulses (intervals) is stored in this octet. It is the divisor for the total measuring range, and is therefore used for the scaling of the encoder.

7.1.2.8 Singleturn / Multiturn (octet 39.1)

This bit (which is normally set by the selection of the encoder class) can be used to select the encoder type.

7.1.2.9 Dimensional unit for velocity/speed (octet 39, 5+4)

If the class HUEBNER 2.2 is selected, then it is possible to output the velocity/speed. Bits 5 and 4 of octet 39 can be used to set the following types of output:

00H	units/second
01H	units/100 milliseconds
10H	units/10 milliseconds
11H	rpm

7.2 Commissioning mode

The commissioning mode is a special feature of normal operation for the encoder classes HUEBNER 2.1 and 2.2. In addition to the preset value and code sequence (count direction), which can also both be altered in normal operation, it is possible to perform a scaling in online operation, through the teach-in method. This just requires manipulating a bit in the status for the DDLM_Data_Exchange mode. To do this, the data are transferred in each cycle as four 8-bit words, as below:

Status +2 ²⁴	2 ²³ - 2 ¹⁶	2 ¹⁵ - 2 ⁸	2 ⁷ - 2 ⁰
-------------------------	-----------------------------------	----------------------------------	---------------------------------

Transfer of the data within a DDLM_DATA_EXCHANGE cycle

The status bits are interpreted as follows:

Bit 25	0 = encoder not ready	1 = encoder ready
Bit 26	0 = commissioning mode	1 = normal mode
Bit 27	0 = software limit switch min. < process value < max.	1 = software limit switch min. > process value > max.
Bit 28	0 = clockwise (looking at end of shaft)	1 = counter-clockwise (looking at end of shaft)
Bit 31	0 = normal mode	1 = set preset value

7.2.1 Accept preset value

The preset value can be taken from the encoder position, both in normal mode and in commissioning mode. The acceptance is made regardless of whether or not bit 26 is set.

	Status bits							Data bits	
	31	30	29	28	27	26	25	24 - 0	
M->S	1	0	0	0	0	x	0	process value is transferred as the preset value	
S->M	1	0	0	0	0	X	0	new process value is transferred	
M->S	0	0	0	0	0	X	0	reset to the commissioning mode	
S->M	0	0	0	0	0	x	0	new process value is output	

M = Master, S = Slave

7.2.2 Set count direction (code sequence)

In commissioning mode, the count direction can be reversed online, by using bit 28. After changing over, the encoder sends back the present direction to the master. A 0 means that the count direction is clockwise (looking at the shaft end), a 1 means it is counter-clockwise (anti-clockwise).

	Status bits							Data bits	
	31	30	29	28	27	26	25	24 - 1	0
M->S	0	0	0	1	0	0	0	bit 28 switches the direction from 0 to 1 or the reverse	
S->M	0	0	0	0/1	0/1	0	1	acknowledge new direction in bit 0	1/0
M->S	0	0	0	0	0	0	0	end changeover for bit 28 = 0	
S->M	0	0	0	0/1	0/1	0	1	continue output of process value	

M = Master, S = Slave



NOTE!

After setting the direction, the preset value has to be set again.

7.2.3 Scaling the encoder with the teach-in method

This method provides an automatic scaling of the encoder. After starting the procedure, the system moves over a defined path. Then the system is stopped, and the number of units into which the path is to be divided is entered. The motion path must not be longer than 2047 revolutions.

7.2.3.1 Start scaling

	Status bits							Data bits
	31	30	29	28	27	26	25	24 – 1
M->S	0	1	0	0	0	0	0	bit 30 = 1 = start scaling
S->M	0	1	0	0/1	0/1	0	1	acknowledge through bit 30 =1
M->S	0	0	0	0	0	0	0	rest the previous scaling
S->M	0	1	0	0/1	0/1	0	1	output of process value, with scaling factor 1

M = Master, S = Slave

After using this function, the gearing factor is set to 1 and the zero offset (preset) is cancelled.

The system must now traverse the path that was defined previously. The motion path is displayed through the process value, without scaling.

7.2.3.2 Stop scaling

	Status bits							Data bits
	31	30	29	28	27	26	25	24 – 1
M->S	0	0	1	0	0	0	0	transfer the number of units for dividing the path
S->M	0	1	1	0/1	0/1	0	1	new total measuring range (should be recorded)
M->S	0	0	0	0	0	0	0	end scaling
S->M	0	0	0	0/1	0/1	0	1	scaled process value is output

M = Master, S = Slave

With scaling, both positive and negative directions of rotation are taken into account, as well as traversing the zero point.

The following must be considered for scaling:

The number of units that is required must not exceed the physical resolution (pulses) of the motion path.

Bit 28 must be set correctly for the count direction. If necessary, it must be set again after using this function.

Since the preset value is cancelled when scaling is started, it must be set again in a subsequent operation.

The scaling is stored in non-volatile memory in the encoder. In order to be able to carry on using the scaling values if the encoder is replaced, it is a good idea to transfer the total measuring range to the Profibus master. There it is entered in the field Measuring units, and the switch Desired measuring units per xxx is set to MAXIMUM TOTAL MEASURING RANGE.

8 Diagnostic messages

The DDLM_Slave_Diag mode makes it possible for the master to call up diagnostic data from the encoder. The number of octets is 57, except for the shorter diagnostics, where the number of diagnostics bytes is limited to 16.

The diagnostic messages which are supported by the HÜBNER absolute encoder are listed below. The diagnostic data are given out in accordance with the rules of the Profibus Profile for Encoders, PNO Order No. 3.062.

Octet	Parameter	Bit – No.			Class
1–3	Station status (see Profibus® standards)				1
4	Diagnostics master add				1
5–6	PNO number	15-0	PNO number of the encoder		1
7	Extended diagnostics header		number of diagnostic bytes		1
8	Alarm message	4	memory error (EEPROM)	1 = error	1
9	Operating mode	0 1 2 3	direction of rotation Class 2 functionality diagnostics routine scaling function	0 = CW, 1 = CCW 0 = off, 1 = on 0 = off, 1 = on 0 = off, 1 = on	1
10	Encoder type	1	Singleturn/Multiturn	single-turn = 0 multi-turn = 1	1
11–14	Resolution per revolution (hardware)	0-23	single-turn resolution	4096 (10 00 H)	1
15–16	Number of revolutions (hardware)	0-23	multi-turn resolution	4096 (10 00 H)	1
20–21	Warning messages	20/4	operating time warning after 105 hours	0 = no, 1 = yes	2
24–25	Profile version	15-8 7-0	revision number index		2
26–27	Software version	15-8 7-0	revision number index		2
28–31	Operating time	23-0	is incremented every 6 minutes, while the supply voltage is applied		2
32–35	Zero point shift	23-0	preset value		2
40–43	Parameterized resolution per revolution	23-0	only if the value Resolution per revolution was entered		2
44–47	Parameterized total measuring range	23-0	parameter setting, or calculated by scaling		2
48-57	Serial number		bytes, filled with 2AH at present		2

9 Faults

9.1 Fault table absolute part

Faults	Possible cause	Remedy
Moisture in the terminal box cover	Soiled gasket or seal surfaces of terminal box cover	Clean gasket of terminal box cover and seal surfaces
	Damaged gasket of terminal box cover	Replace gasket of terminal box cover
	Cable gland/blanking plug not tightened	Tighten cable gland/blanking plug
	Unsuitable cable for cable gland	Use suitable cable and cable glands

9.2 LED display for error and status messages

Two LEDs (one red, one green) are built into the cover of the terminal box, and are visible through a window. They are used to indicate errors and the momentary status of the encoder. Each one of the LEDs can have the state; OFF, BLINKING or ON. This allows 9 possible combinations, of which 6 are used as follows:

LED display in the terminal box cover		
Red LED	Green LED	Error indication / encoder status
off	off	no supply voltage
on	blinking	Parameter or configuration error. The encoder receives wrong configuration data from the master. Possible cause: Total resolution is set to high.
on	off	Encoder has not received data for a longer period (about 40 s). Possible cause: Bus cable is devect.
blinking	on	Encoder is ready for operation but is not addressed by the master. Possible cause: Wrong address setting.
off	blinking	Commissioning mode
off	on	Normal operation mode („data exchange mode“)
on	on	waiting for configuration by the master (e.g. wrong cabling, wrong setting of the termination resistors)

Contact Hubner-Service (page 2) if none of the remedies listed above provides a solution!

10 Inspections

10.1 Safety instructions personnel



WARNING!

Skilled technical staff only are permitted to inspect the device and its installation. Observe the safety instructions contained in **Chapter 2** when inspecting or working on the device!

11 Disposal

11.1 Disposal procedure

The manufacturer is not obliged to take back the device.

The device is classed as electronic equipment and subject to the WEEE Directive; observe local, country-specific laws when disposing of the device.

For information on environmentally sound disposal please contact your local authority or a specialist disposal company.

12 Dimension drawings

12.1 Construction type B5 (flange)

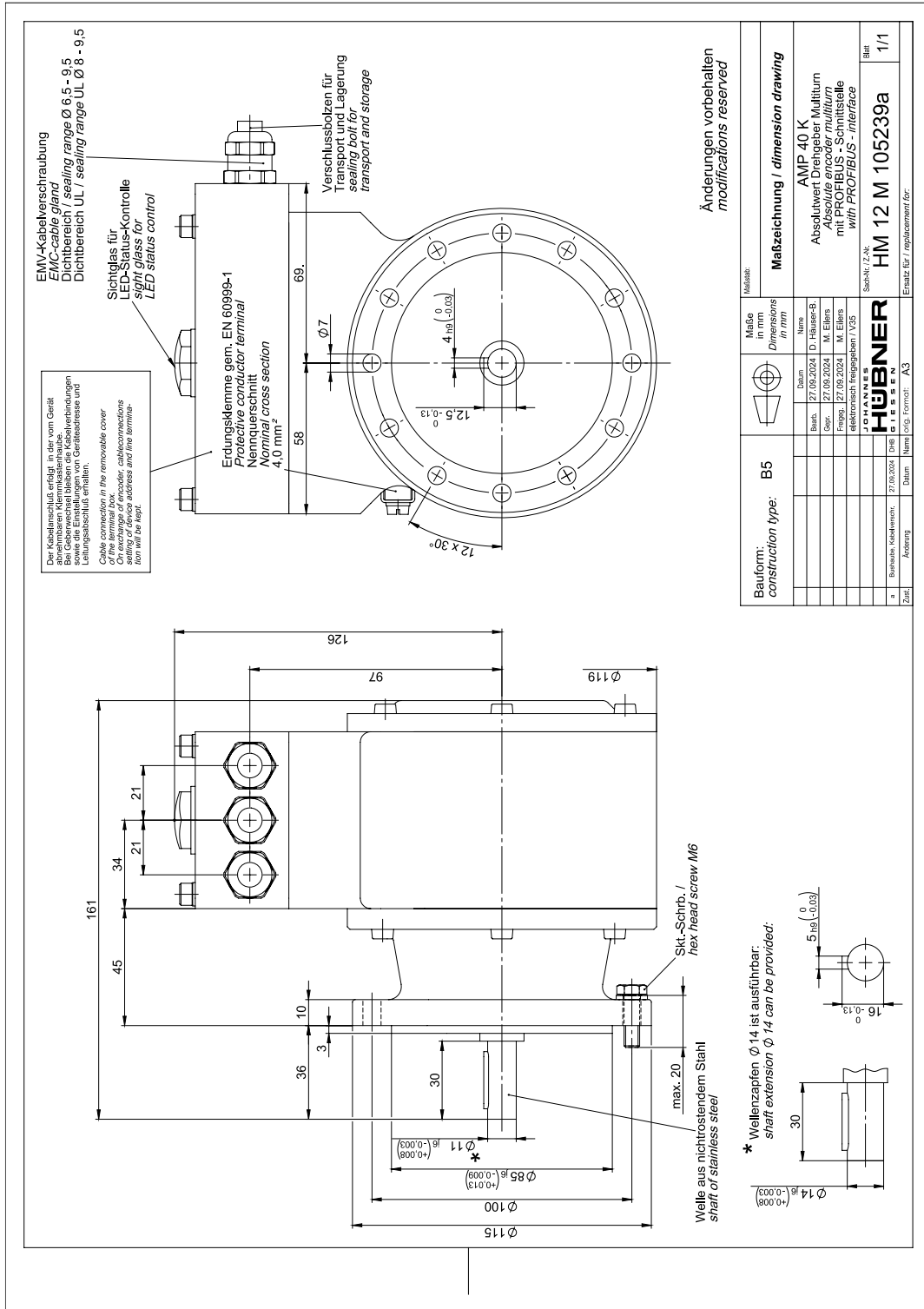

AMP 40 K

Construction type B5

HM 12 M 105239a

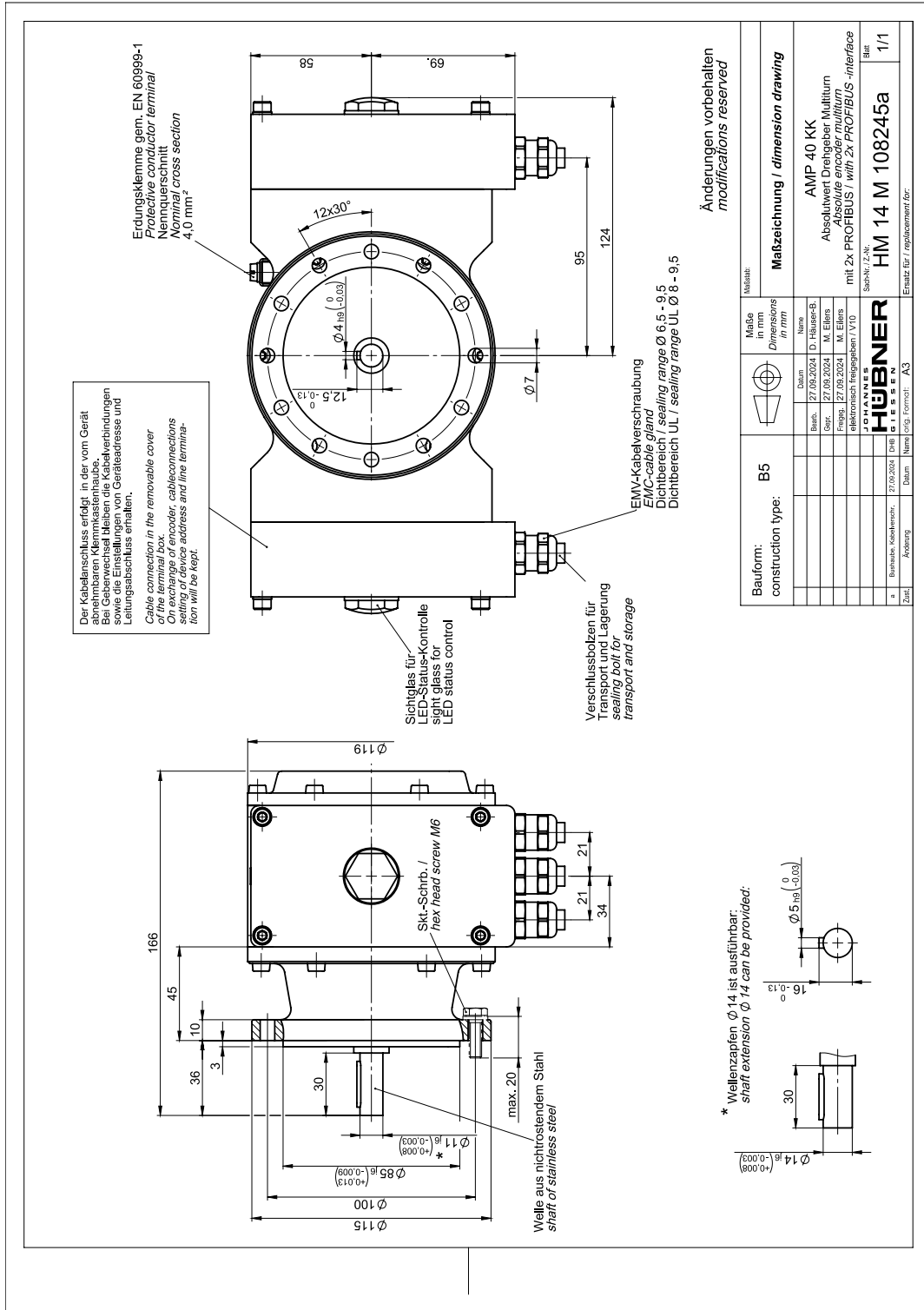

AMP 40 KK

Construction type B5

HM 14 M 108245a

EMV-Kabelverschraubung
EMC-cable gland
Dichtbereich / sealing range $\varnothing 6,5 - 9,5$
Dichtbereich UL / sealing range UL $\varnothing 8 - 9,5$

Zugang zur Kupplung
access to coupling

Zwischenflansch / intermediate flange
D - 52 863 / H - 1954A

Kupplung_L coupling:

Verdrehsteife Kupplung / Torsion-resistant coupling
HK 522 - 11/ d oder / or
HK 522 - 14/ d

Montageanleitung / Mounting instruction : Nr. 54690

Andere Durchmesser siehe Kupplungskatalog!
Other diameters see coupling catalog!

d ⁶⁷	t	u
12	13,8	4
14	16,3	5
16	18,3	5
20	22,8	6
max. bis 22	24,8	6

Andere Durchmesser siehe Kupplungskatalog!
Other diameters see coupling catalog!

Änderungen vorbehalten
modifications reserved

Maße in mm / Dimensions in mm

Maßzeichnung / dimension drawing

Anbau-Maßzeichnung
mounting dimension drawing

AMP40 K - B5

Stück-Nr./Z.Nr.:
HM 16 M 110210a

Blatt
1/1

Erstausführung / replacement for: A3

Zust. Änderung Datum Name Orig. Formel: A3

HUBNER
JOHANNES
GIESSEN
elektronisch reagieren / V10

Beinh. 30.08.2024 D. Häsel-B
Gez. 30.08.2024 M. Elkes
Freige. 30.08.2024 M. Elkes

**Mounting example for construction type B5
with flange and coupling HK 522**

HM 16 M 110210a

12.2 Construction type B35 (flange and foot)

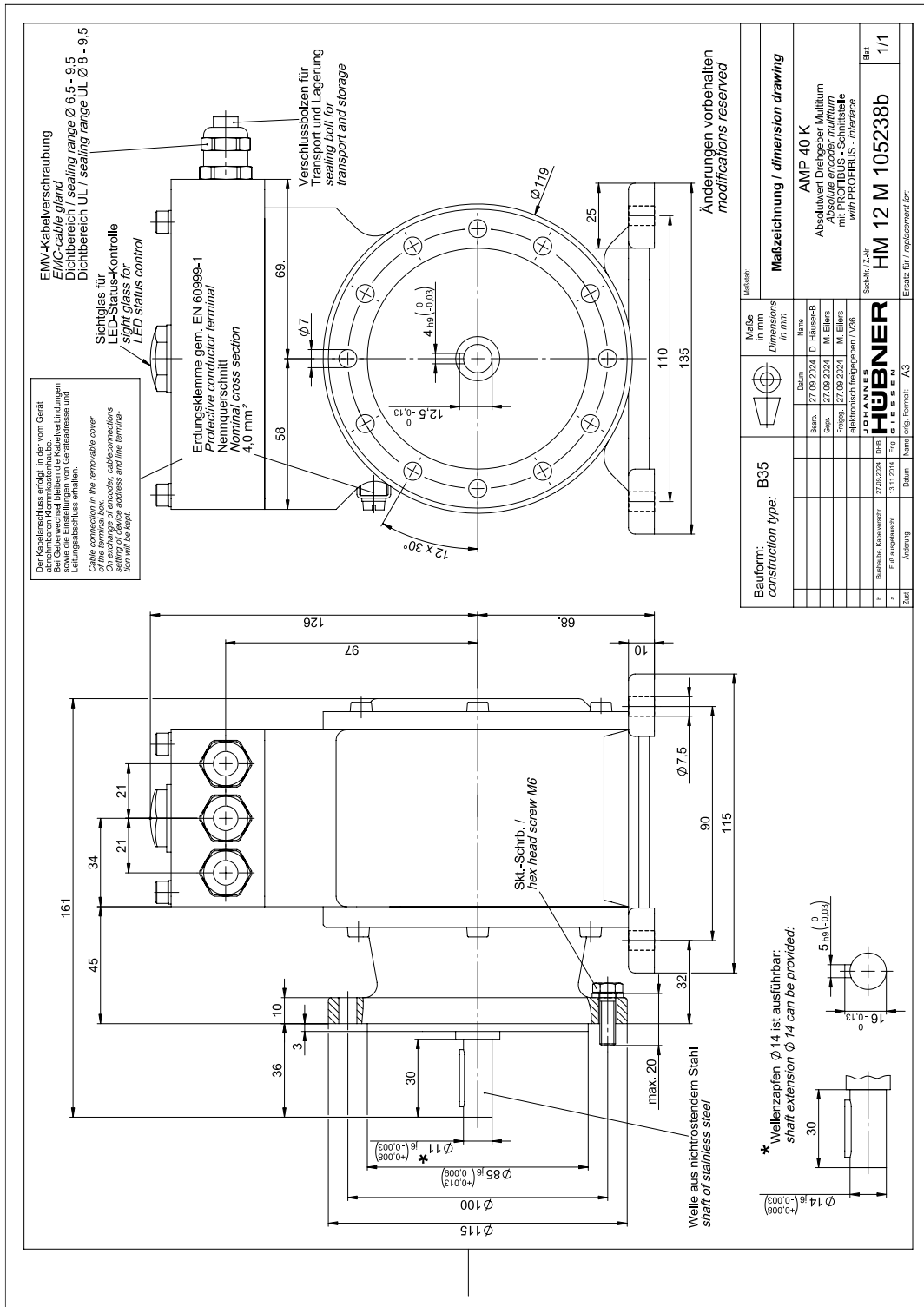

AMP 40 K

Construction type B35

HM 12 M 105238b

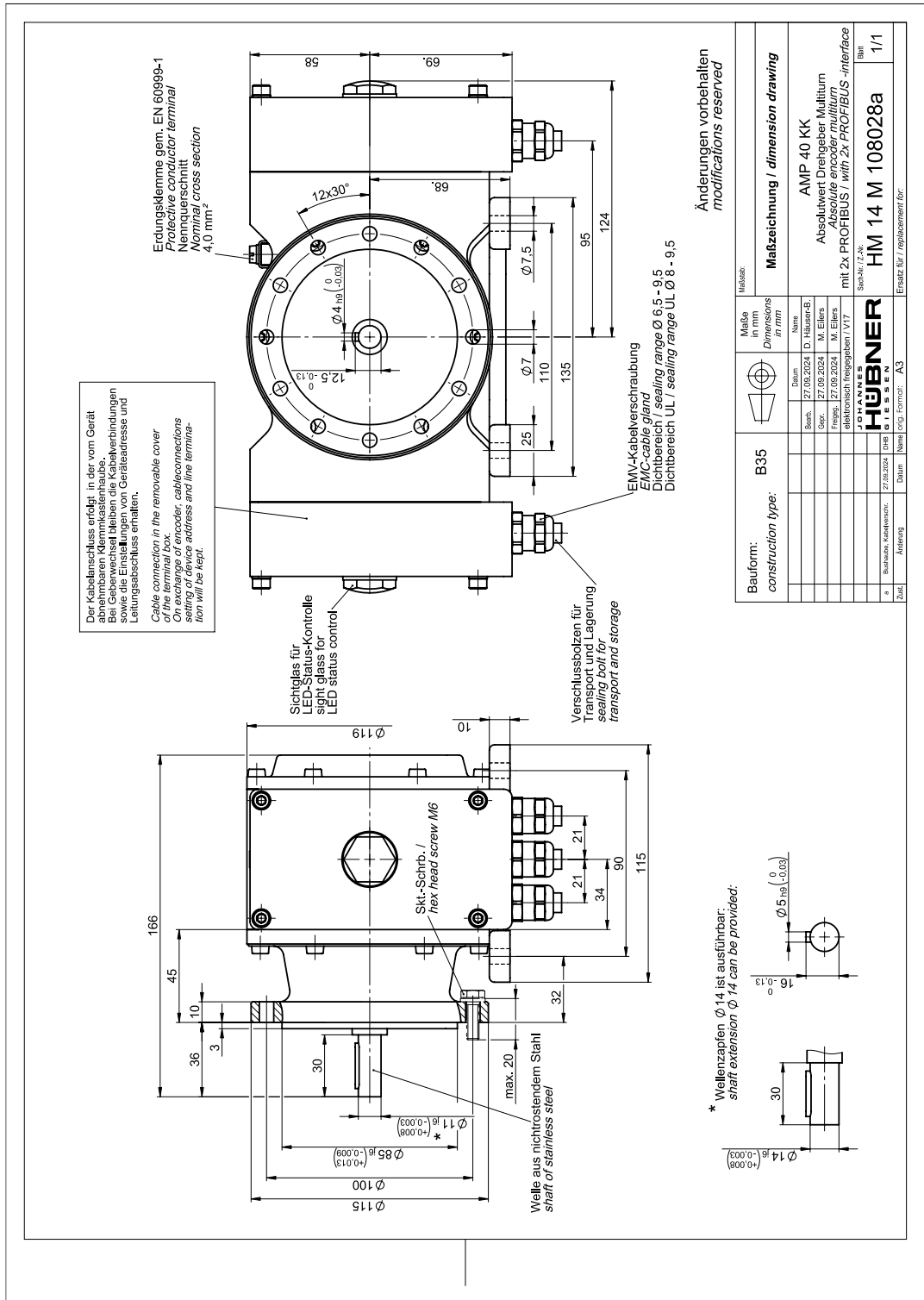

AMP 40 KK

Construction type B35

HM 14 M 108028a

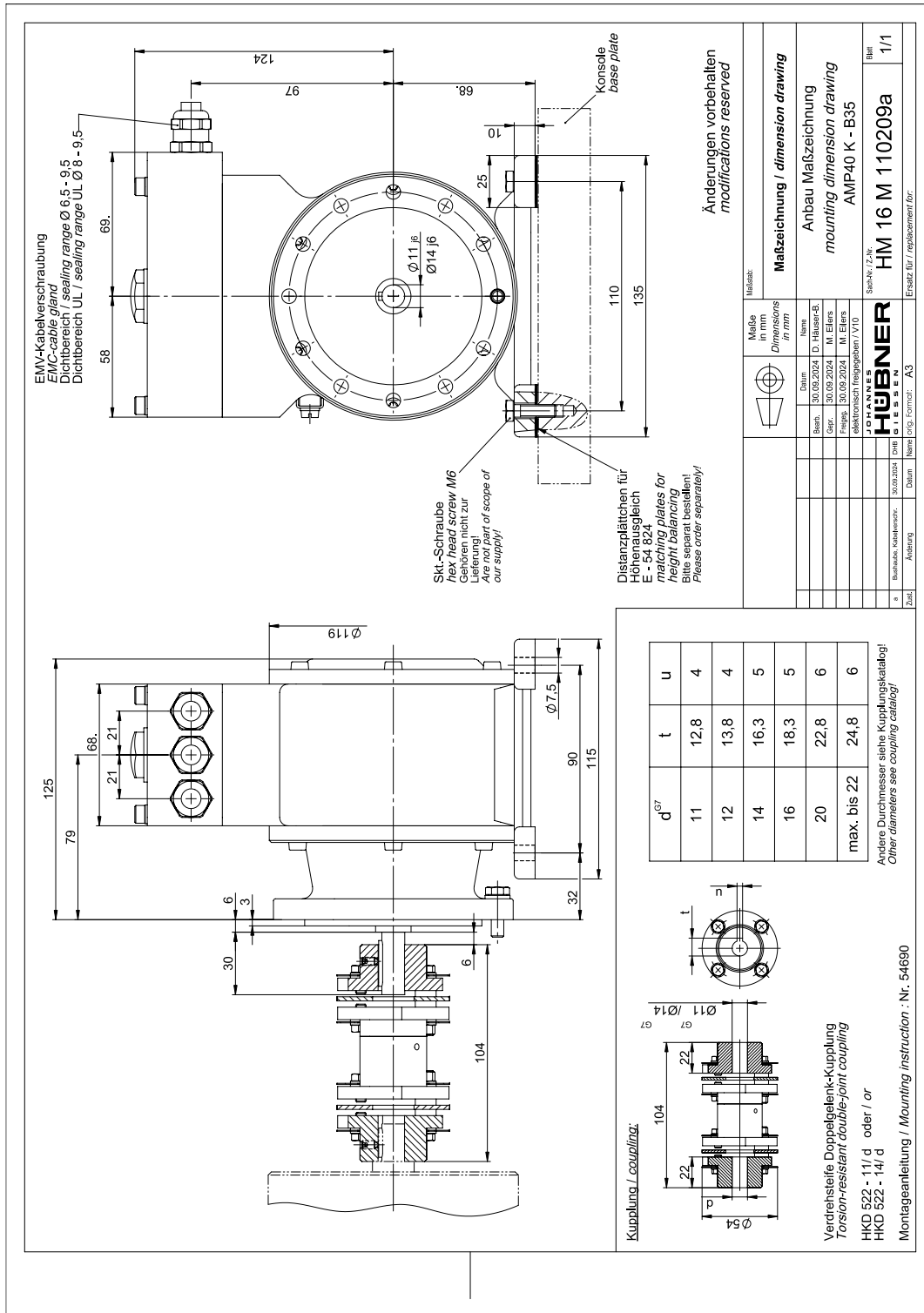

**Mounting example for construction type B35
with coupling HKD 522**

HM 16 M 110209a

13 Dismantling

13.1 Safety instructions

Personnel

Dismantling must be carried out by skilled technical staff only.



WARNING!

Observe the safety instructions contained in **Chapter 2** when inspecting or working on the device!



NOTES!

Do not use a hammer or similar tool when installing the device due to the risk of damage occurring to the bearings or coupling!

13.2 Dismantling the encoder

Remove all electrical cables from the device before dismantling. To dismantling the encoder follow the instructions given in Chapters 5.5 and 5.6 or in the reverse order.