



## Operating and Assembly Instructions

### Basic device UOM 4L-1212 / UOMH 4L-1212

in construction type B5 (flange), B35 (flange and foot) and hollow shaft design



**Read the operating and assembly instructions prior to assembly, starting installation and handling!  
Keep for future reference!**

**Trademark**

**U-ONE®** is a registered trademark of Johannes Hubner Fabrik elektrischer Maschinen GmbH.

**Windows®** is a registered trademark of Microsoft Corporation in the United States and other countries.

**Viton®** is a registered trademark by Du Pont.

**Loctite®** is a registered trademark from Henkel AG & Co. KGaA, Düsseldorf.

All other brand names and product names are trademarks or registered trademarks of their respective owner.

Protected trademarks bearing a <sup>TM</sup> or <sup>®</sup> symbol are not always depicted as such in the manual.

However, the statutory rights of the respective owners remain unaffected.

**Manufacturer / publisher**

Johannes Hübner Fabrik elektrischer Maschinen GmbH

Siemensstr. 7

35394 Giessen

Germany

Telephone: +49 641 7969 0

Fax: +49 641 73645

Internet: [www.huebner-giessen.com](http://www.huebner-giessen.com)

E-Mail: [info@huebner-giessen.com](mailto:info@huebner-giessen.com)

This manual has been drawn up with the utmost care and attention. Nevertheless, we cannot exclude the possibility of errors in form and content. It is strictly forbidden to reproduce this publication or parts of this publication in any form or by any means without the prior written permission of Johannes Hübner Fabrik elektrischer Maschinen GmbH.

Johannes Hübner Fabrik elektrischer Maschinen GmbH is listed by Underwriters Laboratories.

UL certificates can be requested from us.

An overview of our UL devices can be found at the following link:

**<https://iq.ulprospector.com/info>**

**UL File Number: E351535**

Subject to errors and changes due to technical improvements.

Copyright © Johannes Hübner Fabrik elektrischer Maschinen GmbH

All rights reserved.

## Table of contents

<b>1 General</b>	<b>5</b>
1.1 Information about the operating and assembly instructions	5
1.2 Scope of supply	5
1.3 Explanation of symbols	5
1.4 Disclaimer	6
1.5 Copyright	6
1.6 Guarantee terms	6
1.7 Customer service	6
<b>2 Safety</b>	<b>6</b>
2.1 Responsibility of the owner	6
2.2 Personnel	7
2.3 Personal protective equipment	7
2.4 Special dangers	8
2.4.1 Electrical current	8
2.4.2 Rotating shafts / Hot surfaces	8
2.4.3 Safeguarding against restart	8
<b>3 Technical Data</b>	<b>9</b>
3.1 Type plate	9
3.2 Type key	9
3.3 Electrical and mechanical data	10
3.3.1 Connected loads, environment	10
3.3.2 Mechanical Data	10
3.3.3 Degree of protection	11
3.3.4 Dimension drawings	12
<b>4 Installation and commissioning UOM(H) 4L-1212</b>	<b>20</b>
4.1 Safety instructions	20
4.2 Technical information	20
4.3 Required tools	21
4.4 Mounting preparations	21
4.5 Mounting B5 type (flange)	21
4.6 Mounting B35 type (flange and foot)	23
4.7 Mounting tolerances for Construction Type B5 and B35	24
4.8 Attaching additional devices	25
4.9 Mounting hollow-shaft type	26
4.10 Installation	28
4.10.1 General rules	28
4.10.2 Connecting	29
4.10.3 Connecting the fiber optic cable	30
4.11 Dismantling	31
4.11.1 Safety instruction	31
4.11.2 Dismantling the universal encoder type B5 and B35	31
4.11.3 Dismantling hollow shaft type	31
4.12 Electrical / fiber optic connection and commissioning	31
4.12.1 Electrical / fiber optic connection	32
4.13 Intended use	33
4.14 Improper use	33
4.15 Inspections	33

4.15.1	Safety advice for personnel .....	33
4.15.2	Maintenance information .....	33
4.15.3	Inspection schedule .....	34
4.16	Fault table .....	34
<b>5</b>	<b>Replacement parts .....</b>	<b>34</b>
<b>6</b>	<b>Transport, packaging and storage .....</b>	<b>35</b>
6.1	Safety information concerning transport .....	35
6.2	Goods inward inspection .....	35
6.3	Packaging (disposal) .....	35
6.4	Storing packages (devices) .....	35
6.5	Returning devices (repairs/goodwill/warranty).....	35
6.6	Disposal .....	35

## 1 General

### 1.1 Information about the operating and assembly instructions

These operating and assembly instructions provide important instructions for working with the device. They must be carefully read prior to starting all tasks, and the instructions contained herein must be followed.

In addition, applicable local regulations for the prevention of industrial accidents and general safety regulations must be complied with.

For other, non SIL certified electronic function modules please refer to the separate Operating and Assembly Instructions.

### 1.2 Scope of supply

The scope of supply for the basic device includes the universal encoders UOM 4L-1212 or UOMH 4L-1212, the fastening screws as well as the Operating and Assembly Instructions.

The exact scope of supply is listed in the order confirmation.

### 1.3 Explanation of symbols

Warnings are indicated by symbols in these operating and assembly instructions. The warnings are introduced by signal words that express the scope of the hazard.

The warnings must be strictly heeded; you must act prudently to prevent accidents, personal injury, and property damage.



**WARNING!**

Indicates a possibly dangerous situation that can result in death or serious injury if it is not avoided.



**CAUTION!**

Indicates a possibly dangerous situation that can result in minor injury if it is not avoided.



**CAUTION!**

Indicates a possibly dangerous situation that can result in material damage if it is not avoided.



**NOTES!**

Indicates useful tips and recommendations as well as information for efficient and trouble-free operation.



**NOTES!**

Do not use a hammer or similar tool when installing the device due to the risk of damage occurring to the bearings or coupling!



**DANGER!**

**Life-threatening danger due to electric shock!**

Indicates a life-threatening situation due to electric shock. If the safety instructions are not complied with there is danger of serious injury or death. The work that must be executed should only be performed by a qualified electrician.

## 1.4 Disclaimer

All information and instructions in these (assembly) instructions have been provided under due consideration of applicable guidelines, as well as our many years of experience.

The manufacturer assumes no liability for damages due to:

- Failure to follow the instructions in the (assembly) instructions
- Non-intended use
- Deployment of untrained personnel
- Opening of the device or conversions of the device

In all other aspects the obligations agreed in the delivery contract as well as the delivery conditions of the manufacturer apply.

## 1.5 Copyright



### NOTES!

Content information, text, drawings, graphics, and other representations are protected by copyright and are subject to commercial property rights.

It is strictly forbidden to make copies of any kind or by any means for any purpose other than in conjunction with using the device without the prior written agreement of the manufacturer. Any copyright infringements will be prosecuted.

## 1.6 Guarantee terms

The guarantee terms are provided in the manufacturer's terms and conditions.

## 1.7 Customer service

For technical information personnel is available that can be reached per telephone, fax or email. See manufacturer's address on page 2.

# 2 Safety



### DANGER!

This section provides an overview of all the important safety aspects that ensure protection of personnel, as well as safe and trouble-free device operation.

If these safety instructions are not complied with significant hazard can occur.

## 2.1 Responsibility of the owner

The device is used in commercial applications. Consequently the owner of the device is subject to the legal occupational safety obligations, and subject to the safety, accident prevention, and environmental protection regulations that are applicable for the devices area of implementation.

---

## **2.2 Personnel**

Qualified personnel only are permitted to install, mount, program, commission, operate, maintain and take out of service the devices.

Qualified personnel are people who have received

- training to qualify as an electrician or
- instructions from qualified trades personnel

entitling them to work with and on devices, systems, machinery and plant in accordance with generally accepted standards and safety engineering guidelines.

In addition, the owner is obliged to deploy only personnel who

- are familiar with the fundamental regulations covering work safety and accident prevention,
- have read and understood the chapter "Safety" in these Operating and Installation Instructions,
- and are familiar with the basic and specialist standards that apply to the specific application.

## **2.3 Personal protective equipment**

Wear personal protective equipment such as safety shoes and safety clothing to minimise risks to health and safety when carrying out work such as installation, disassembly or commissioning. Adhere to all applicable statutory regulations as well as the rules and standards determined by the owner.

## 2.4 Special dangers

Residual risks that have been determined based on a risk analysis are cited below.

### 2.4.1 Electrical current



**DANGER!**

**Life-threatening danger due to electrical shock!**

There is an imminent life-threatening hazard if live parts are touched. Damage to insulation or to specific components can pose a life-threatening hazard.

**Therefore:**

Immediately switch off the device and have it repaired if there is damage to the insulation of the power supply.

De-energize the electrical equipment and ensure that all components are connected for all tasks on the electrical equipment.

Keep moisture away from live parts. Moisture can cause short circuits.

### 2.4.2 Rotating shafts / Hot surfaces



**WARNING!**

**Danger of injury due to rotating shafts and hot surfaces!**

Touching rotating shafts can cause serious injuries.

**Therefore:**

Do not reach into moving parts/shafts or handle moving parts/shafts during operation.

Close to protect from injury all access openings in flanges with the corresponding plug screw, and provided you exposed rotating components with protective covers.

Do not open covers during operation. Prior to opening the covers ensure that all parts have come to a standstill.

The encoder can become hot during prolonged use.

In case of contact risk of burns is existing.

### 2.4.3 Safeguarding against restart



**DANGER!**

**Life-threatening danger if restarted without authorization!**

When correcting faults there is danger of the power supply being switched on without authorization.

This poses a life-threatening hazard for persons in the danger zone.

**Therefore:**

Prior to starting work, switch off the system and safeguard it from being switched on again.



### 3 Technical Data

#### 3.1 Type plate

The following figure shows an example of a type plate.

The type plate and UKCA label are located on the side of the housing.

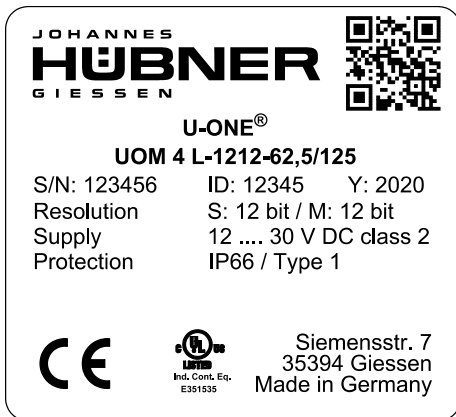

Type plate information:

- Manufacturer, address
- CE-mark
- Type, year of construction (Bj/Y)
- Serial number (S/N)
- Commission number (C/N)
- Max. speed
- Supply voltage
- Switching voltage / max. switching current
- Certification
- Resolution
- QR-Code

#### 3.2 Type key

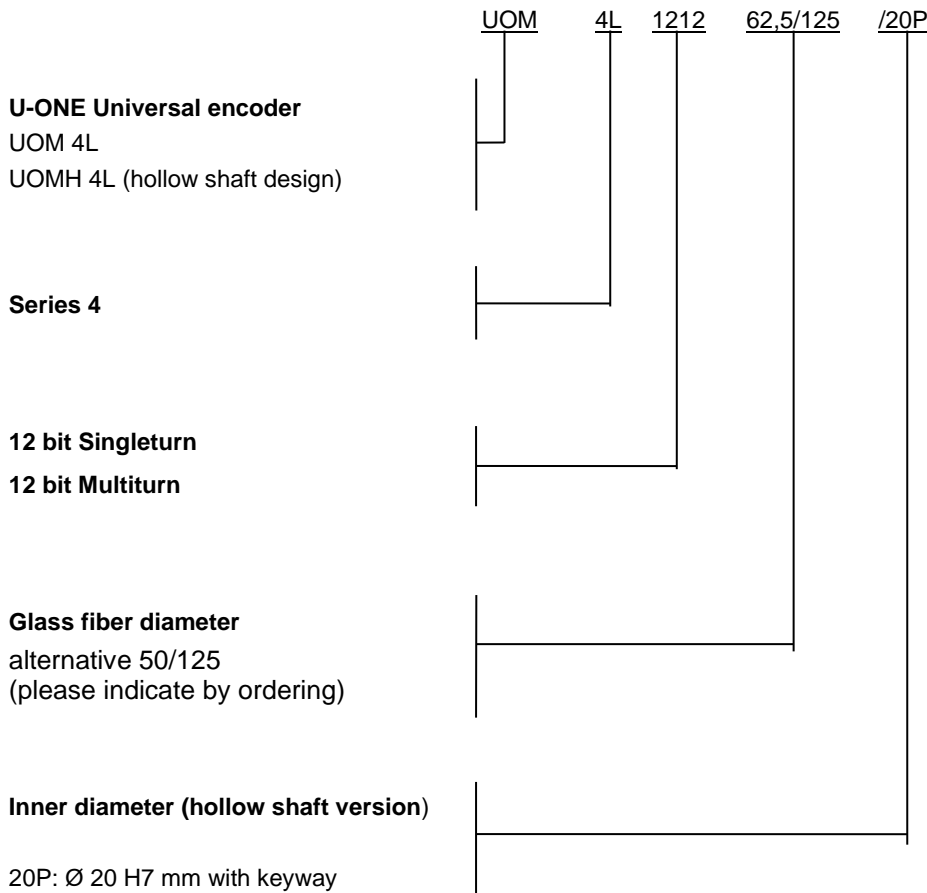

### 3.3 Electrical and mechanical data

#### 3.3.1 Connected loads, environment

Basic device UOM(H) 4L-1212	Electrical Data	Worth
	Supply voltage	12 ... 30 V DC
	Power consumption	max. 2 W
	Resolution incremental	1024 symmetrical square wave pulses
	Absolut Singleturn	12 Bit (4096 steps per Revolution)
	Absolut Multiturn	12 Bit (4096 Revolutions)
	Signal transmission	by means of fiber optic cable for cable 50/125µm or 62,5/125µm
	Connection diagram see page 32	EL 667 b
	Device temperature range	-25 to +85°C

The UOM(H) 4L-1212 is categorised in Group 1 and Class A in accordance with EN 55011 and is only intended for use in an industrial environment.

Basic device UOM 4L-1212:	Mechanical Data	Worth
	Shaft end	11j6x30 mm (Standard) 14j6x30 mm (optional)
	Degree of protection	IP 55 or IP 66 according EN 60529
	max. permissible speed	3000 rpm
	Electrically and fiber optic connection	Terminal box COMBICON terminal strip 2 x ST-plug connection for fiber optics cable 50/125 µm or 62,5/125 µm
Basic device UOMH 4L-1212	Inner diameter	20 H7 with keyway

#### 3.3.2 Mechanical Data

Description		Worth	
UOM 4L-1212	Max. encoder shaft load	$F_{a \text{ max. (axial)}}$ = 100 N $F_{r \text{ max. (radial)}}$ = 120 N	
	Shaft end	11j6 x 30 mm (standard) 14j6 x 30 mm (optional)	
	Weight	UOM 4L-1212 with one shaft end with two shaft ends	Approx. 3,4 kg Approx. 4,3 kg
UOMH 4L-1212	Weight	UOMH 4L-1212	Approx. 4,1 kg

### 3.3.3 Degree of protection

Degree of protection acc.to DIN EN 60529	Sealing	Permissible speed	Rotor moment of inertia (1 shaft end)	Breakaway torque	
UOM 4L-1212	IP 55	Standard	≤ 3000 rpm	Approx. 975 gcm <sup>2</sup>	Approx. 8 Ncm
	IP 66	with axial shaft seal	≤ 3000 rpm	Approx. 975 gcm <sup>2</sup>	Approx. 10 Ncm
	IP 66	with radial shaft seal (for special applications, e.g. wet areas in rolling mills)	≤ 3000 rpm	Approx. 975 gcm <sup>2</sup>	Approx. 11 Ncm
UOMH 4L-1212	IP 55	Standard	≤ 3000 rpm	Approx 2440 gcm <sup>2</sup>	Approx.15 Ncm
	IP 66	with axial shaft seal	≤ 3000 rpm	Approx. 2440 gcm <sup>2</sup>	Approx.30 Ncm
	IP 66	with radial shaft seal (for special applications, e.g. wet areas in rolling mills)	≤ 3000 rpm	Approx. 2440 gcm <sup>2</sup>	Approx.35 Ncm
Vibration resistance	DIN IEC 68-2-29 (50...2000 Hz)		20g		
Shock resistance	DIN IEC 68-2-29		100g		



#### NOTES!

Thermal factors influencing the permissible maximum speed of the UOM(H) 4 L are determined by the place of installation. The maximum ambient temperature of the place of installation should not exceed 70°C ...75 °C (85 °C version).

It is possible to determine the maximum permissible ambient temperature for the UOMH 4 as follows:

$$n_{therm,zul.} = \frac{85\text{ °C} - T_{umg}}{9 \cdot 10^{-3} \frac{K}{1/min}}$$

T<sub>umg</sub>.: Temperature of the relevant attachment point

Verification measurements may be required in some individual cases.

3.3.4 Dimension drawings

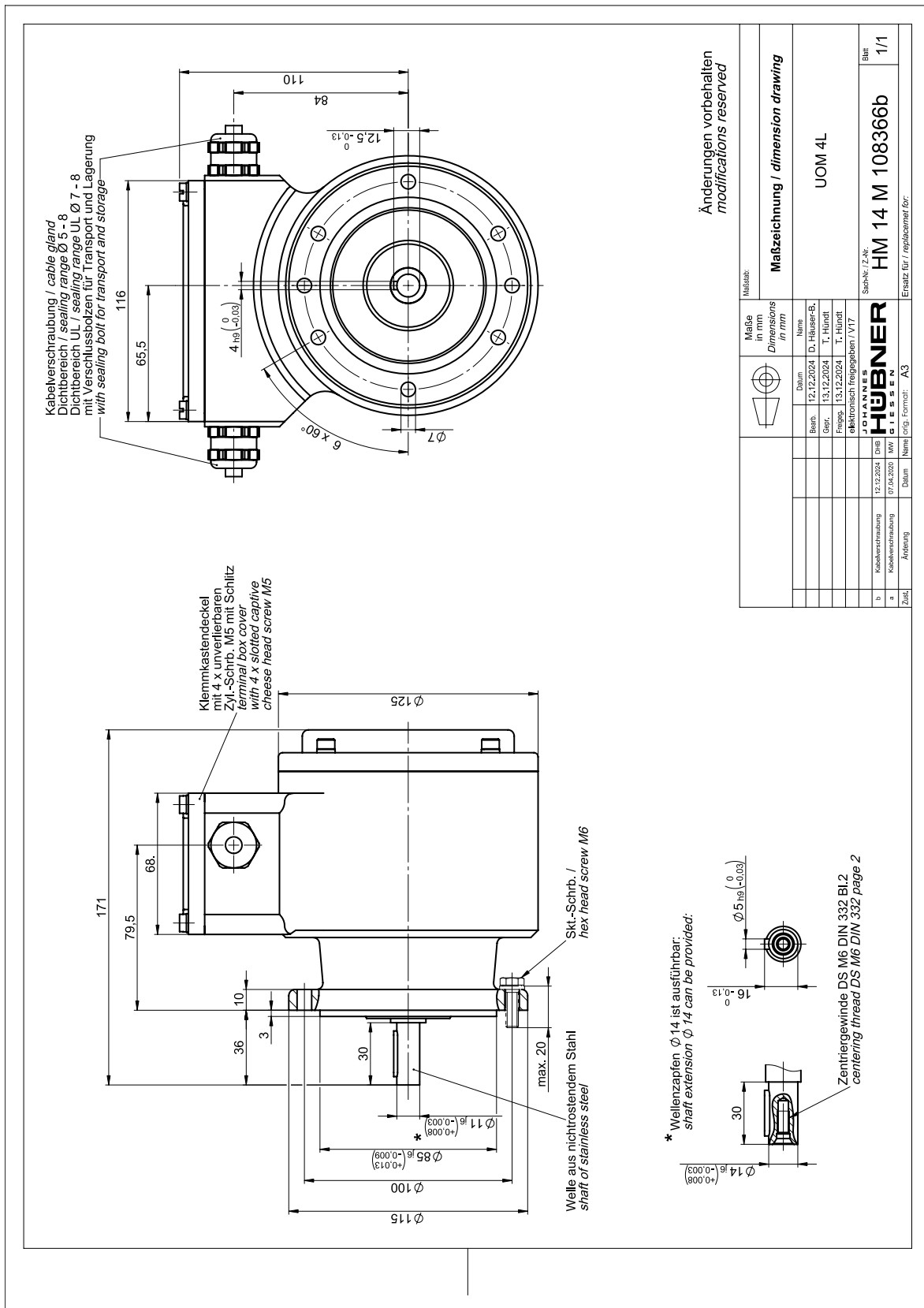

# Universal Encoder System U-ONE®

## Basic device UOM(H) 4L-1212

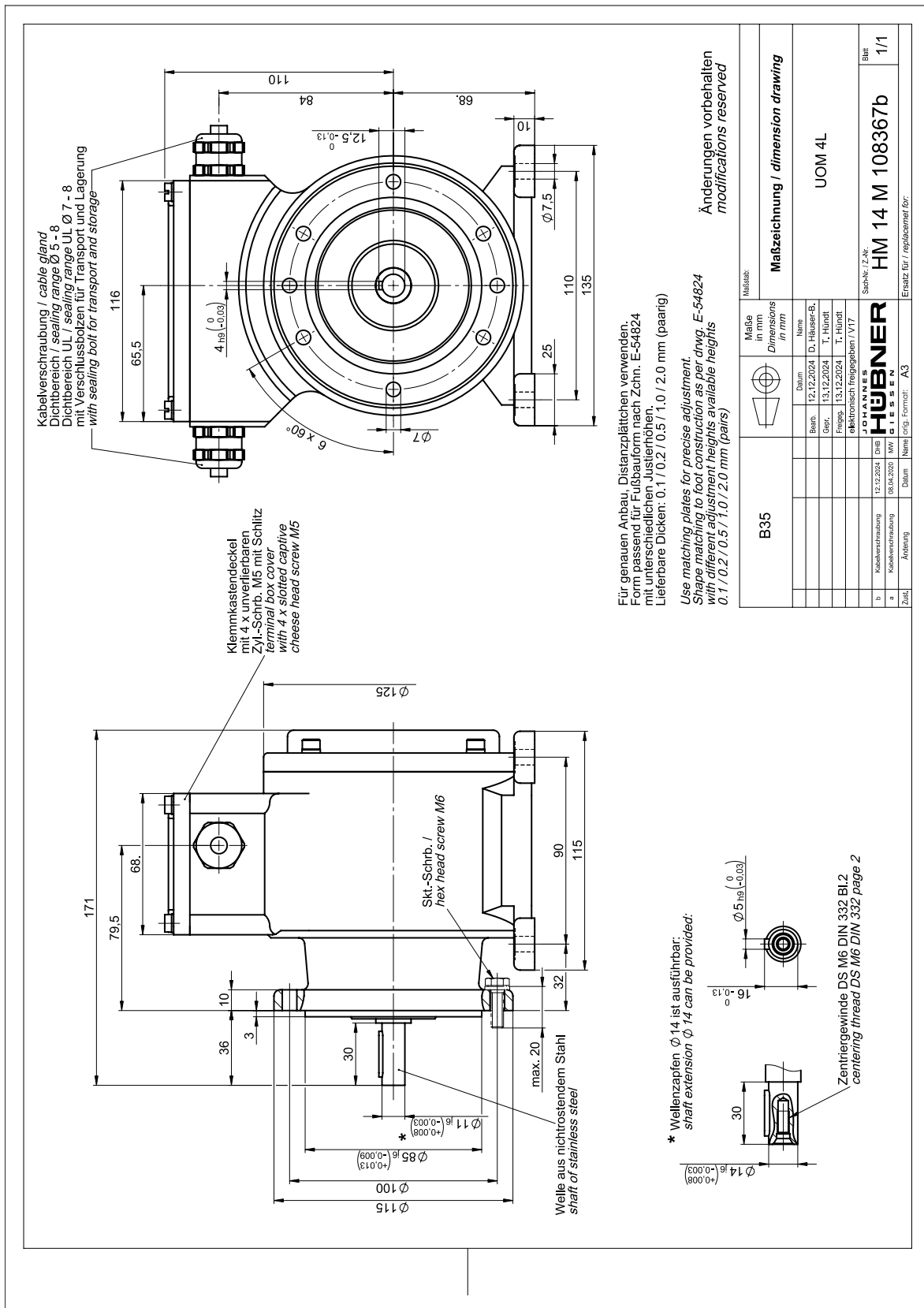

Für genauen Anbau, Distanzplättchen verwenden.  
Form passend für Fußbauforn nach Zchn. E-54824  
mit unterschiedlichen Justierhöhen.  
Lieferbare Dicken: 0.1 / 0.2 / 0.5 / 1.0 / 2.0 mm (paarig)

Use matching plates for precise adjustment.  
Shape matching to foot construction as per drwg. E-54824  
with different adjustment heights available heights  
0.1 / 0.2 / 0.5 / 1.0 / 2.0 mm (pairs)

Änderungen vorbehalten  
modifications reserved

B35		Maße in mm Dimensions in mm		Maßzeichnung / dimension drawing	
Adaptung	Datum	Name	Drwg. Format	A3	
	12.12.2024	D. Hübner-B.			
	13.12.2024	T. Hündt			
	13.12.2024	T. Hündt			
		elektronisch freigegeben / V17			
		JOHANNES HÜBNER GIESSEREI		Stap-Nr. / Z.Nr.	
				HM 14 M 108367b	
				Blatt	
				1/1	

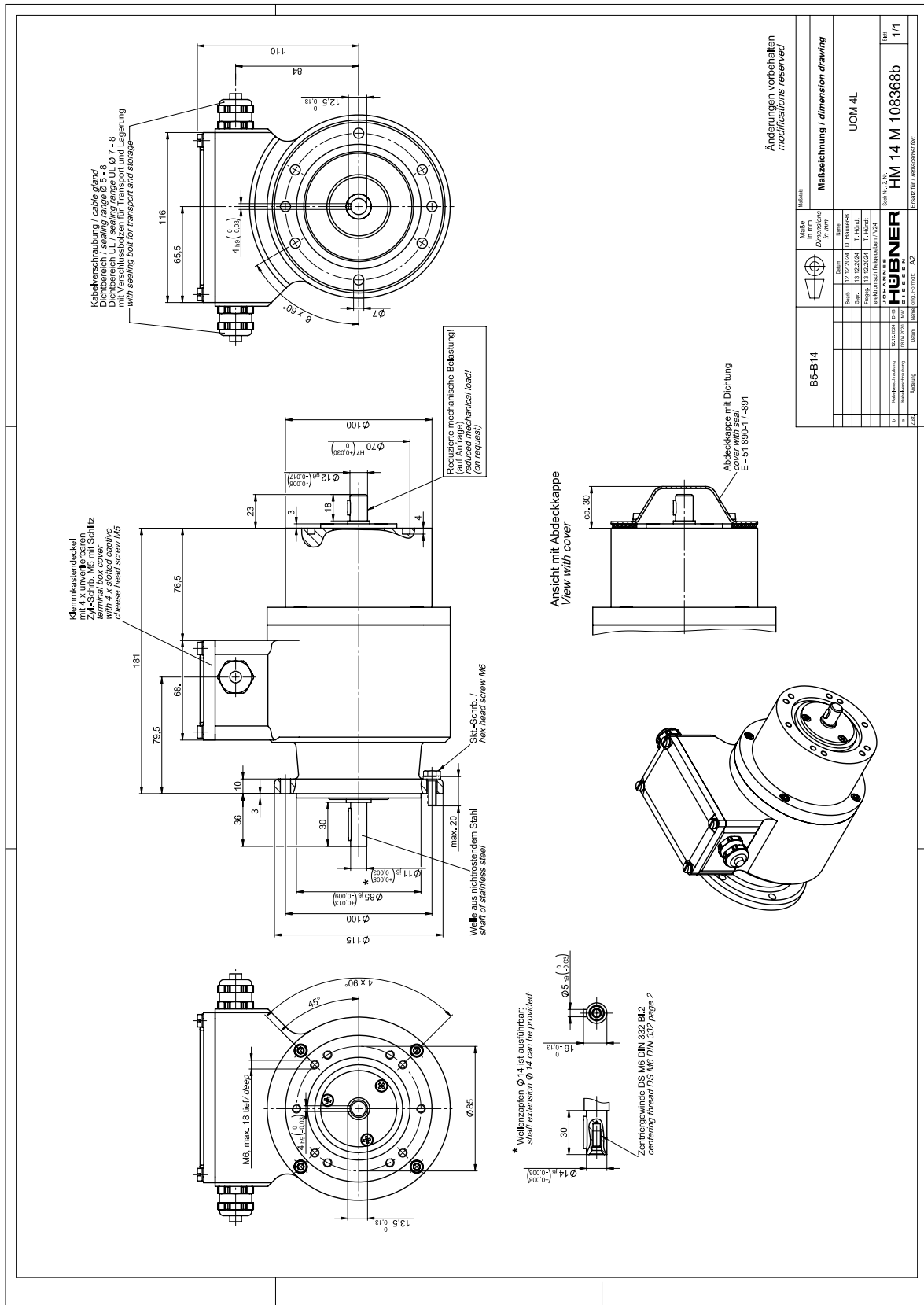

# Universal Encoder System U-ONE<sup>®</sup>

## Basic device UOM(H) 4L-1212

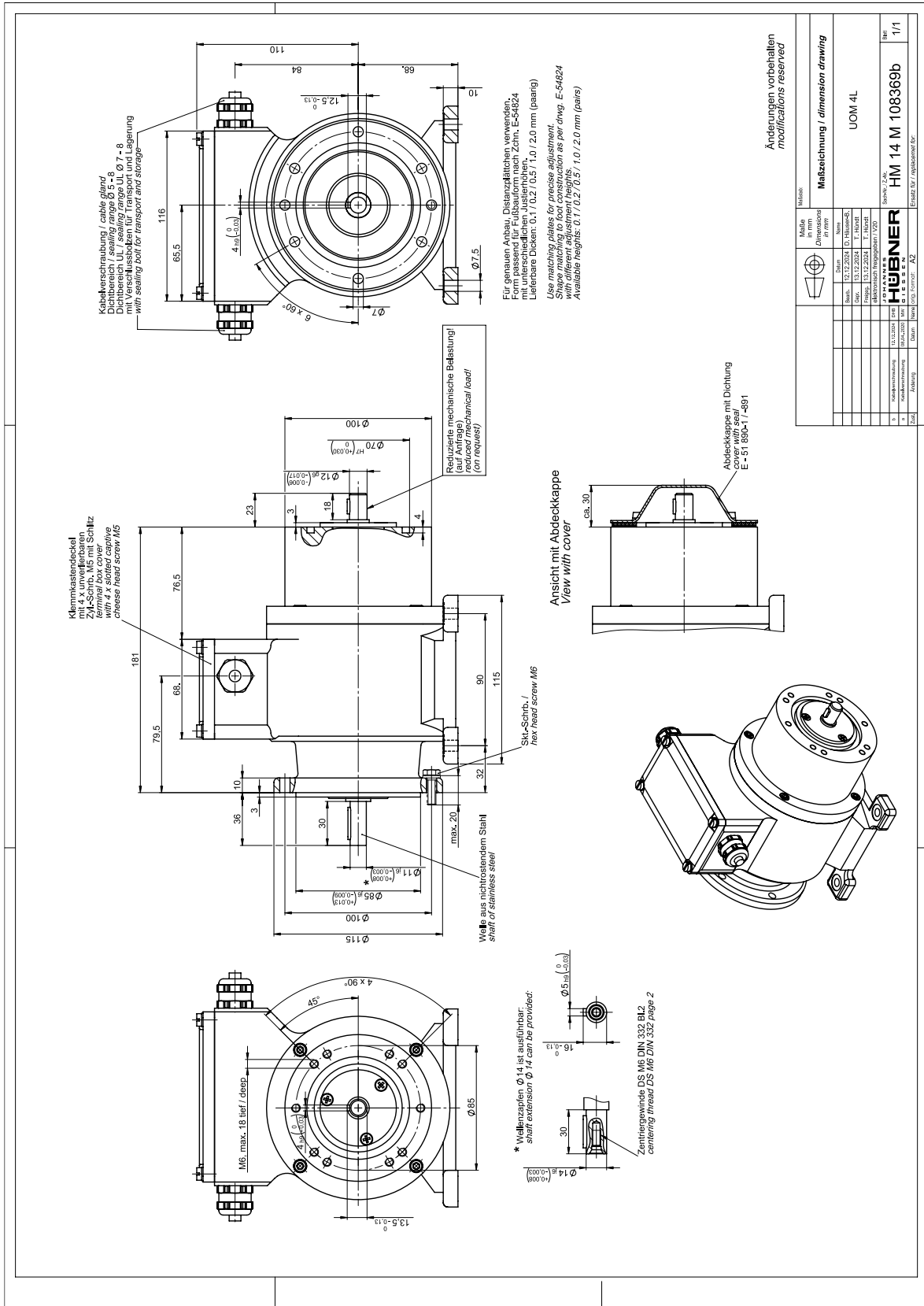

U-ONE<sup>®</sup>

Construction type B35/B14

HM 14 M 108369b

**Kabelverschraubung / cable gland**  
Dichtbereich / sealing range  $\varnothing$  5 - 8  
Dichtbereich UL / sealing range UL  $\varnothing$  7 - 8  
mit Verschraubungen für Transport und Lagerung  
with sealing bolts for transport and storage

**M20 x 1.5**

**Getriebe-Nocken-Endschalter**  
Geared cam limit switches  
Baureihe / series 110, B3  
 $\varnothing$ 10 f7 x 21 \*\*  
Firma Stromag

**Zwischenflansch ZWI-SR**  
intermediate flange  
EI-102227

**Zwischenflansch ZWI-Fla**  
intermediate flange  
D-56072  
Kupplung / coupling type  
HK5333 - 12 / 10 \*\*

**UO 4L**  
B35 / B14  
\* Sonderausführung  
special type

**\*\* Sonderpassfeder 4 breit**  
special feather key

Für genaueren Anbau Distanzplättchen verwenden.  
Form passend zur Fußbauform nach Zorn, E-54824  
mit unterschiedlichen Justierhöhen lieferbare Dicken.  
*Use matching plates for precise adjustment.*  
*Shape matching to foot construction as per drawing, E-54824*  
*with different adjustment heights available heights*  
*0; 1/0,20; 3/1,02; 6 mm (pairs)*

**Änderungen vorbehalten**  
modifications reserved

C	281
B	221
A	156
Getriebegrösse / Geared size	L

**Maßzeichnung / dimension drawing**  
UOM4 L / UOM41 L  
mit Getriebe-Nocken-Endschalter Reihe 110  
with geared cam limit switches

**Stromag / Z.A.N.**  
HM 11 M 104513b  
Blatt 1/1

**U-ONE®**

Maße in mm / Dimensions in mm	Name	Datum	U-ONE®
Bearb.	03.12.2024	D. Häuser-E.	
Geogr.	13.12.2024	T. Hündt	
Freigegeben	13.12.2024	T. Hündt	
Elektronisch freigegeben / V24			
<b>JOHANNES HÜBNER GIESSEN</b>			
Änderung	03.12.2024	DHB	
Zust.	09.04.2020	DHB	
Änderung	Name: HÜB	Format: A3	

**\* AS-Wellenzapfen  $\varnothing$ 14j6 ist ausführbar**  
DE shaft  $\varnothing$ 14j6 can be provided

**U-ONE®**

**Construction type B35/B14 with geared cam limit switch**

**HM 11 M 104513b**



# Universal Encoder System U-ONE®

## Basic device UOM(H) 4L-1212

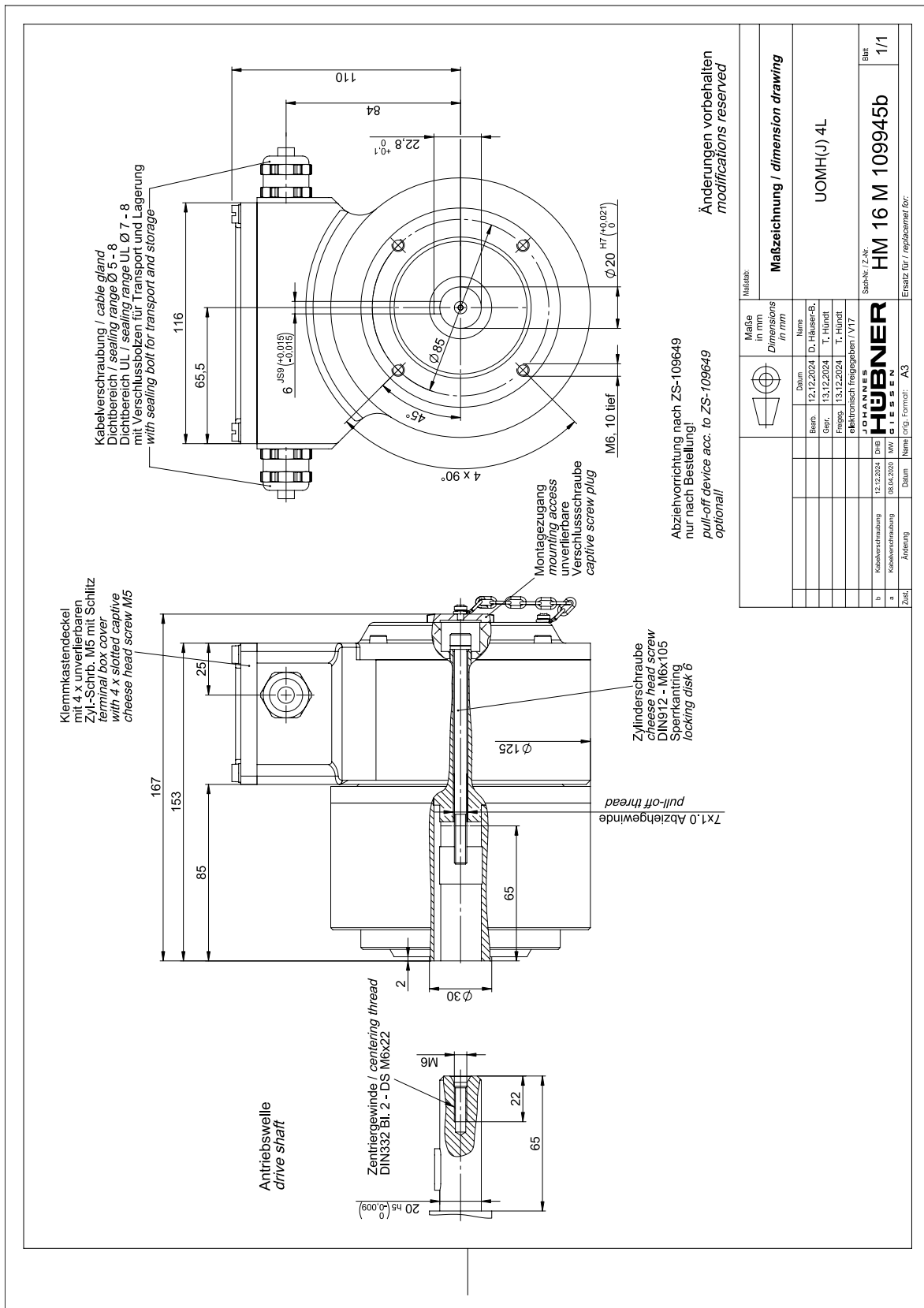

Maße in mm Dimensions / / mm		Name	
Bearb.	12.12.2024	D. Hülser-B.	
Gepr.	13.12.2024	T. Hundt	
Freige.	13.12.2024	T. Hundt	
elektronisch freigegeben / V17			
JOHANNES HÜBNER GIESSSEN			
Stap-Nr. / Z.Nr.	HM 16 M 109945b		
Blatt	1/1		
Einsatz für / replacement for:			
Adaption	Datum	Name	Form: A3
	08.04.2020	MV GIESSSEN	

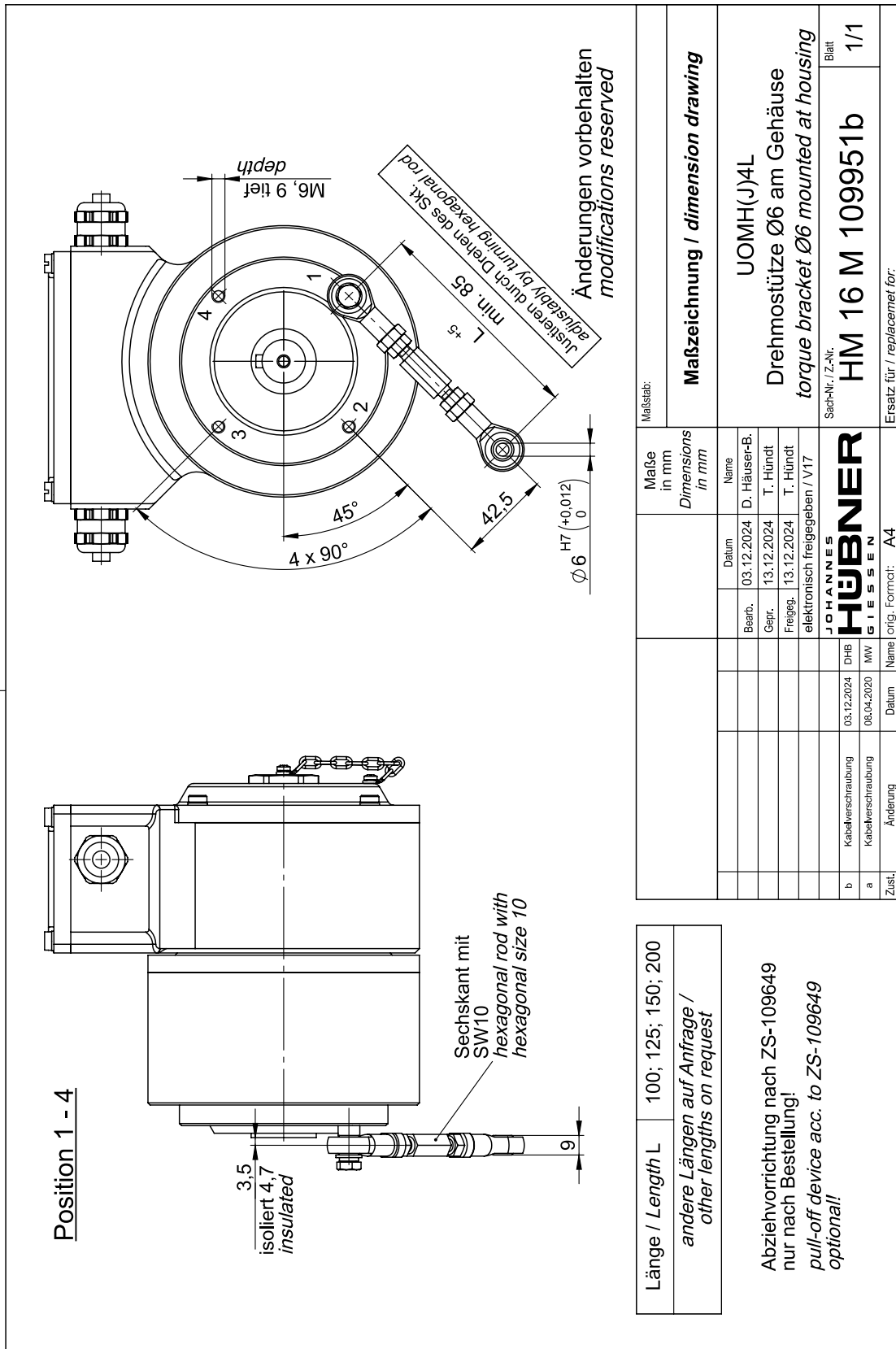

# Universal Encoder System U-ONE®

## Basic device UOM(H) 4L-1212

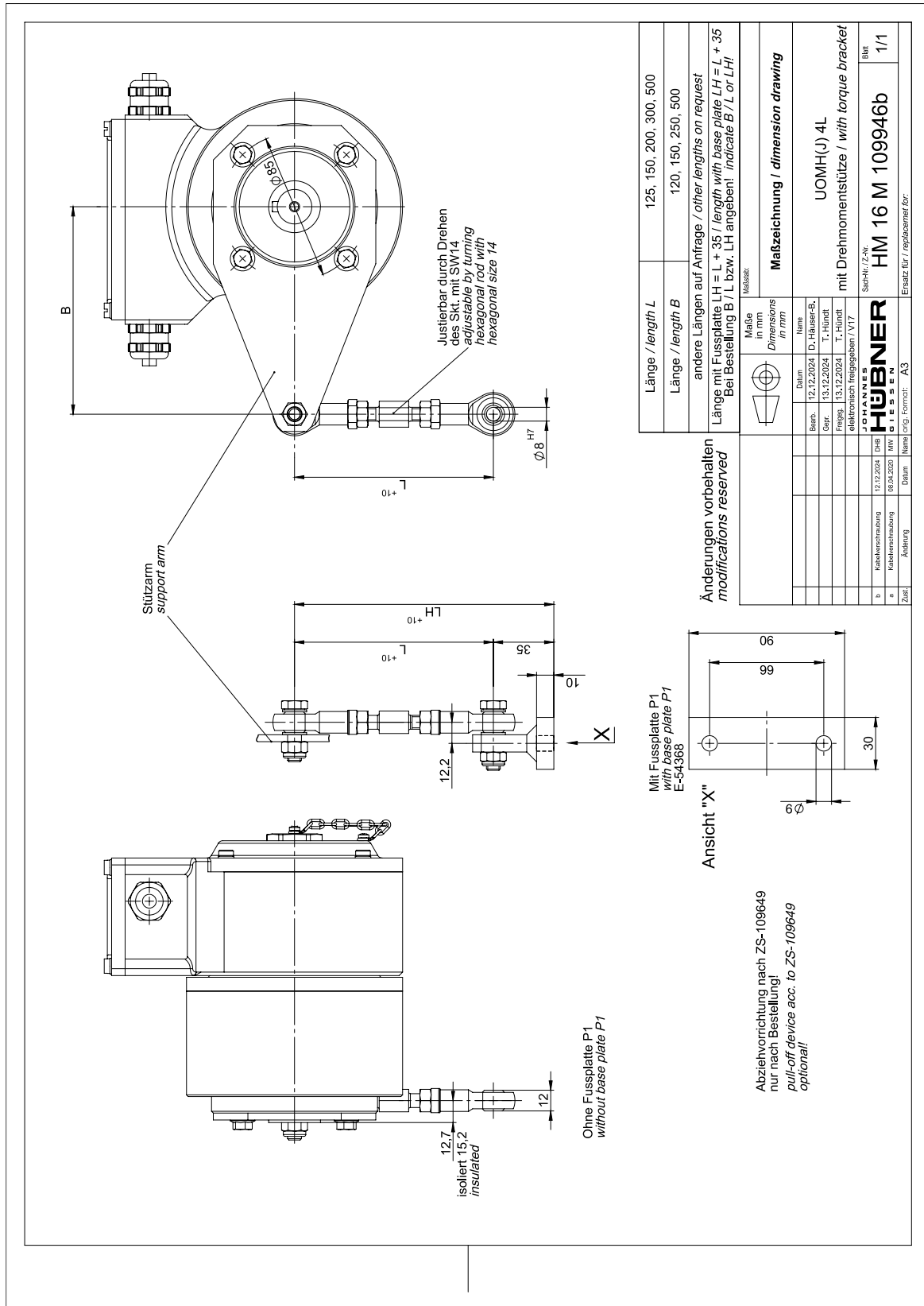

## 4 Installation and commissioning UOM(H) 4L-1212

### 4.1 Safety instructions



**NOTES!**

Observe the safety instructions contained in **Chapter 2** when installing or working on the device!

In conjunction with the electronic function modules UO-EM-D2 and UO-EM-EGS4 the universal U-ONE 4 series encoder system is a switching device designed to ensure the safety of machines, devices and systems in line with application requirements, and contribute towards the overall classification of a given safety category.

**Inspection**

Observe and adhere to all relevant regulations, guidelines and laws when utilising the UO-EM-EGS4 to monitor overspeeds in safety-relevant machines and systems. Inspect the device on a regular basis. Inspections must be recorded in a log book (see Inspection schedule chapter 4.15.3). Furthermore, we remind you of your obligation to adhere to the various relevant country-specific laws, guidelines and standards. You must also observe the supplied operating and installation instructions that in addition to specifying safety and commissioning procedures for the device, individual components and the entire system also define regular inspection schedules (electrical and mechanical functional testing).

**Personnel**

Installation and commissioning must be carried out by qualified personnel only. (See chapter 2.2).

### 4.2 Technical information



**NOTES!**

Do not use a hammer or similar tool when installing the device due to the risk of damage occurring to the bearings or coupling!

**Ambient temperature**

The max. permissible ambient temperature depends on the speed and degree of protection of the device, the signal frequency, the length of the signal cable and the place of installation (please refer to Chapter 3.3).

**Degree of protection**

To fulfill degree of protection requirements the diameter of the connection cable must correspond to that of the cable gland (please refer to Chapter 3.3.4 dimension drawings)

**Deep groove ball bearings**

The universal encoder from the series U-ONE® 4 is fitted with maintenance-free, lifetime lubricated deep groove ball bearings. Opening the device renders the guarantee null and void, and withdrawal of SIL approval.

**Screw retention**

We recommend applying Loctite® 243 (medium strength threadlocker) to all fastening screws to prevent them becoming loose.

### 4.3 Required tools

- Spanners: 10 mm, 13 mm, 22 mm, 24 mm
- Allen keys: 2 mm, 3 mm, 5 mm
- Flat-blade screwdrivers:
- Assembly grease (acid-free)
- Loctite® 243 (medium strength threadlocker)

### 4.4 Mounting preparations

1. Ensure all accessories are available (please refer to Chapter 3.3.4 dimension drawings).
2. Preparing the place of attachment: Clean the (motor) shaft, centering, bolting surfaces and fastening threads; check for damage. Repair any damage!

### 4.5 Mounting B5 type (flange)

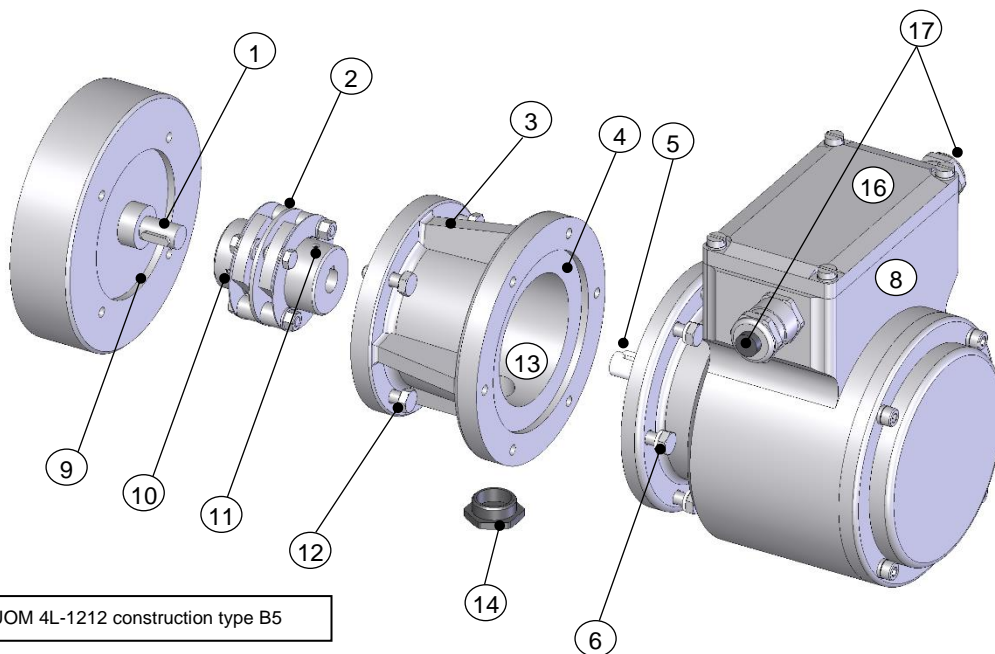

Fig.1: UOM 4L-1212 construction type B5

1. Lightly grease the (motor) shaft (1) and centering (9).
2. Fit coupling (2) onto (motor) shaft.



#### NOTES!

You must be able to mount the coupling without force. Ream out the bores of used couplings, if necessary! We recommend our zero-backlash, torsion-resistant HK 5 coupling to attach the UOM 4 L-1212. Please refer to the catalogue Torsion Resistant Couplings for encoders.

3. Secure the coupling hub on the (motor) shaft with a grub screw or cheese head screw (10) (depending on the coupling type).
4. Fasten the intermediate flange (3) to the motor using the fastening screws (12).



**NOTES!**

If possible, fit the intermediate flange in a manner that ensures the screwed sealing plug (14) points downwards!

5. Lightly grease the universal encoder shaft (5) and centering (4).
6. Fit the universal encoder UOM 4L-1212 (8) into both the centering (4) and coupling hub at the same time.



**NOTES!**

You must be able to mount the coupling without force. Ream out the bores of used couplings, if necessary!

7. Secure the universal encoder UOM 4L-1212 with 4 - 6 screws (6) evenly distributed around the circumference of the flange.
8. Remove the sealing plug (14) from the access bore (13) to the coupling.
9. Secure the coupling hub on the universal encoder shaft with a grub screw or cheese head screw (11) (depending on the coupling type).



**NOTES!**

To carry out this task, it may be necessary to turn the (motor) shaft to the correct position.

10. Close the access opening to the coupling with the screw plug (14).

#### 4.6 Mounting B35 type (flange and foot)



**NOTES!**

B35 type encoders can be attached by means of a flange (B5, please refer to Chapter 4.5) or foot (B3):

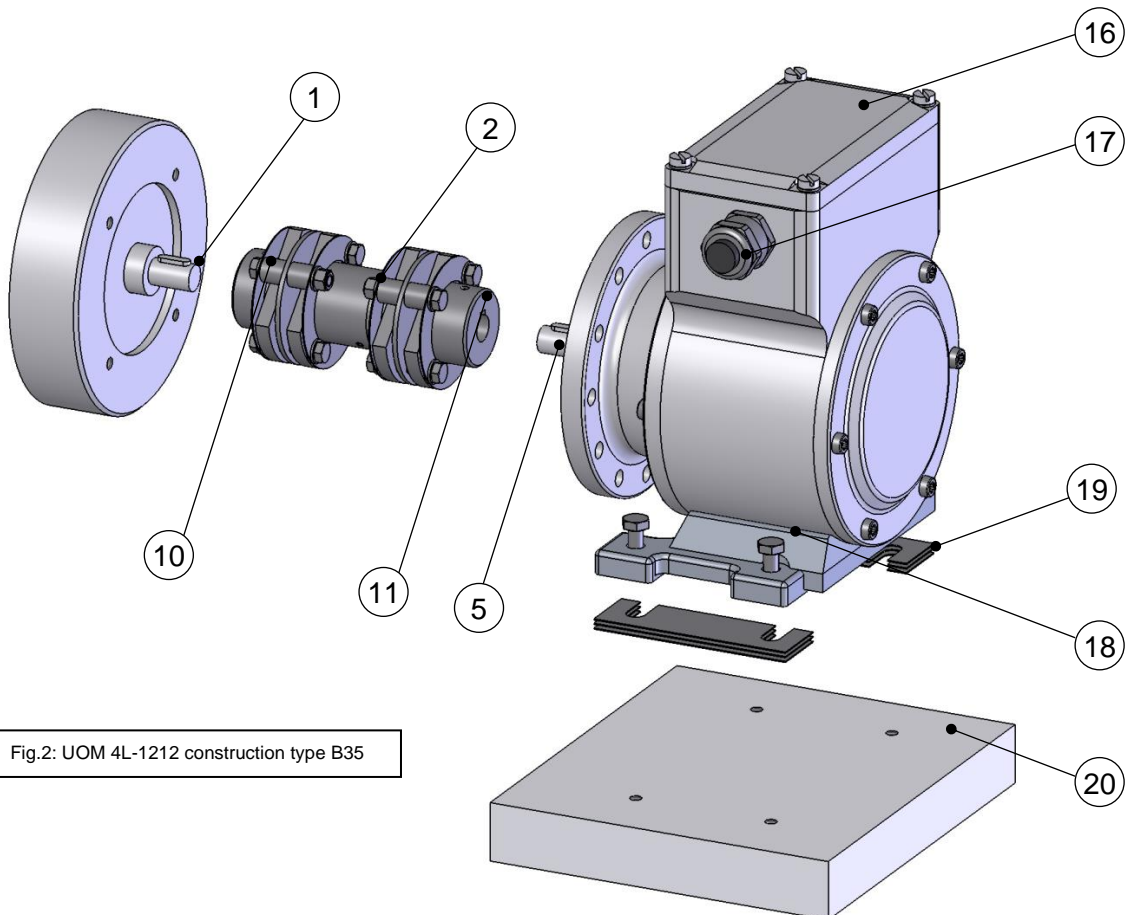

Fig.2: UOM 4L-1212 construction type B35

1. Grease the (motor) shaft lightly(1).
2. Fit coupling (2) onto (motor) shaft.



**NOTES!**

You must be able to mount the coupling without force. Ream out the bores of used couplings, if necessary!



**NOTES!**

We recommend our zero-backlash, torsion-resistant **double-joint coupling HKD5** to attach B35 type encoders. Please refer to the catalogue *Torsion Resistant Couplings for Encoders*.

3. Secure the coupling hub on the (motor) shaft with a grub screw or cheese head screw (10) (depending on the coupling type).

4. Align the universal encoder shaft (5) to the (motor) shaft and insert into the coupling hub.



**NOTES!**

Use shims (19) to achieve the correct vertical alignment to the base plate (20).  
**Observe information in Chapter 4.7 about mounting errors and max. permissible mounting tolerances!**

5. Fasten universal encoder foot with 4 M6 hexagon head screws (18).

6. Secure the coupling hub on the universal encoder shaft with the grub screw or cheese head screw (11) (depending on the coupling type).



**NOTES!**

To avoid injuries by turning parts, the coupling must be provided before introduction with a suitable cover.

**4.7 Mounting tolerances for Construction Type B5 and B35**



**NOTES!**

Angle misalignment and parallel displacement between the (motor) shaft and the encoder shaft are mounting errors and should be kept as small as possible.

**Mounting errors**

- Cause radial forces to act on the encoder shaft.
- Reduce the service life of the bearings and the coupling.
- Degrade the quality of the signals (harmonic content).

Mounting tolerances for our zero-backlash, torsion-resistant couplings HK5 and HKD5:

Coupling	Axial offset a	Angular error $\alpha$	Parallel offset e
HK 5	$\pm 1$ mm	0.5°	-
HKD 5	$\pm 1.5$ mm	0.5°	0.5 mm



## 4.8 Attaching additional devices



### NOTES!

The universal encoder (1) in B5/B14 or B35/B14 has a second shaft extension and a B14 type flange on the non-drive end, onto which it is possible to fit an additional device with a B5 flange via an intermediate flange (2), for example an incremental encoder, absolute encoder, cam limit switch (3) or an overspeed switch.

This design option makes it possible to combine up to two devices.

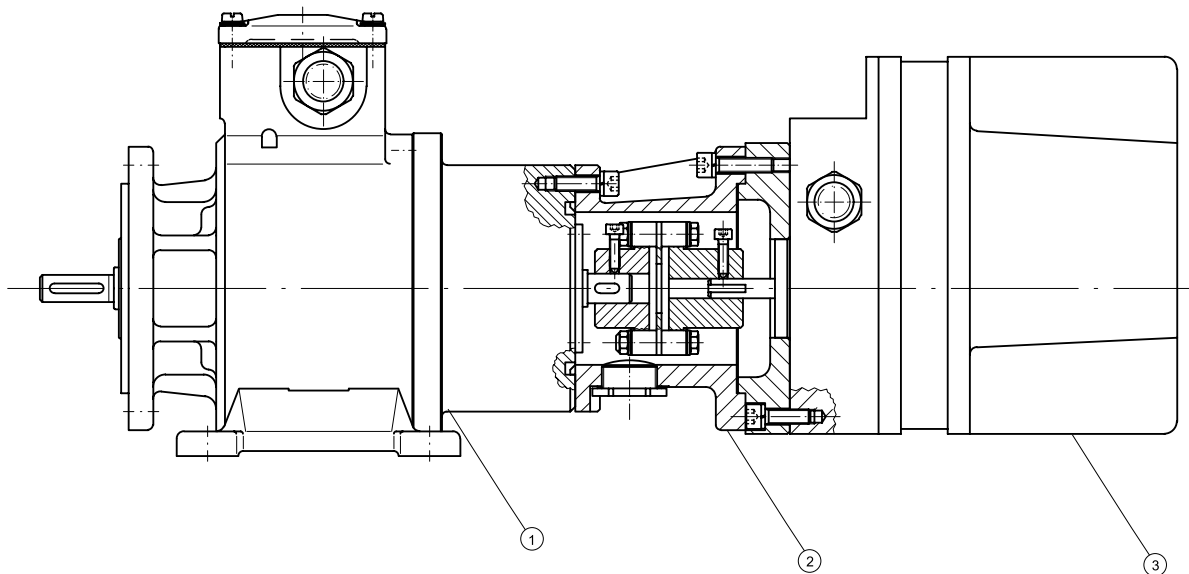

Fig.3: UOM 4L-1212 construction type B35 with coupled geared cam limit switch

When supplied ex works the second shaft end is protected by a cover plate

1. Remove the cover plate.



### NOTES!

Ensure no liquids or dirt are allowed ingress into the device when the cover plate is removed.



### WARNING!

If no second device is added ensure the cover plate is fitted to protect and cover the second shaft end. This prevents the risk of injury and maintains the protection class rating of the device. Replace the cover plate if there is any delay when fitting a second device.

#### 4.9 Mounting hollow-shaft type

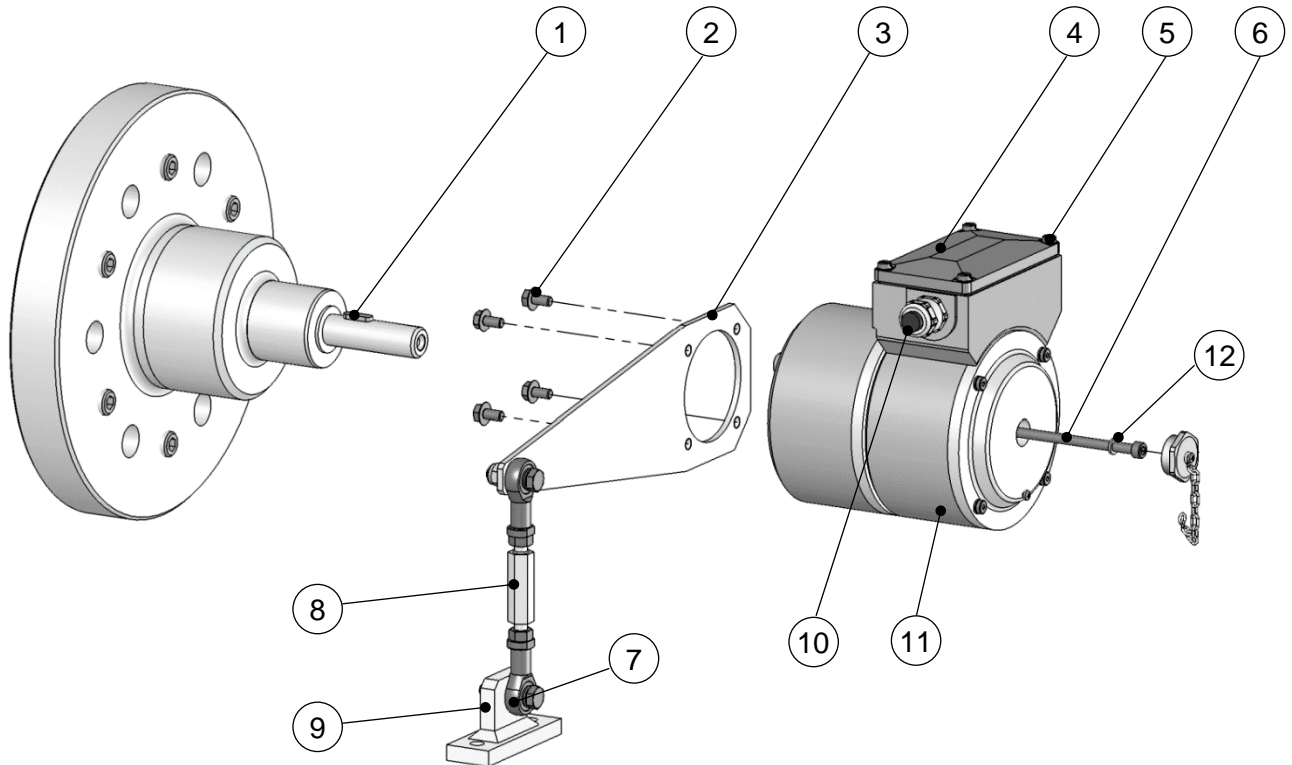

1. Mount adapter shaft (1) and align using dial gauge.

**NOTES!**

The maximum radial run-out of the adapter shaft is 0.05 mm.

If necessary, use the ball thrust adjustment screw to align the adapter shaft. Secure ball thrust screws with Loctite® 243. Remove unused ball thrust screws or secure with Loctite® 243. Max. tightening torque for M12 approx. 25 Nm, for M16 approx. 35 Nm.

Use parallel keys to DIN 6885.

Please also observe the supplement data sheet *Mounting accuracy for hollow shaft encoders*.

You should also observe the Installation instructions supplied with the adapter shaft when installing!



2. Grease the adapter shaft lightly.
3. Secure the torque bracket (3) to the hollow-shaft device (11) with 4 tensilock screws (2).
4. Mount the hollow-shaft device to the adapter shaft.

**NOTES!**

The hollow shaft device must slide easily onto the adapter shaft. Never use excessive force, otherwise the bearings may be damaged. If necessary, use emery cloth or a file to produce a better fit between the adapter shaft and the key. Do not allow the device to hit hard against the collar of the shaft.



5. Secure the hollow-shaft device using the cheese head screw (6) and locking collar (12) size 6.
6. Seal installation access.

7. Fastening the torque bracket:

Ideally, the bracket arm (3) should be mounted at an angle of 90° to the link rod (8).

Fastening without base plate:

Secure the link rod head (7) of the link rod (8) to a fixed point (for example on the motor housing).

Fastening with base plate:

Secure the base plate (9) to a fixed point with two hexagon head screws (for example on the motor housing or the foundations).



**NOTES!**

Once fitted the link rod must rotate easily around the link rod heads! Failure to observe this point may result in damage to the bearings!



**NOTES!**

The link heads are maintenance free. However, ensure they remain free from soiling and paint!

## 4.10 Installation

### 4.10.1 General rules

#### NOTES!

In environments with high drive power, external systems can generate high electromagnetic emissions. Adverse effects on UOM(H) 4L-1212 operation can be avoided by observing the following guidelines:

- Uninterrupted, low-resistance machine grounding must be ensured across all parts of a plant. Ensure that the connections have good electrical contact. Poor conductivity can be caused, for example, by paint, lubricants, corrosion or similar. In practice, large cable cross-sections are required for low-resistance machine grounding.
- Generous mounting distances must be maintained from actuators with a high energy density, such as contactors, inverters, motors, solenoid valves and brakes.
- Shielding of cables must be carried out professionally, for example between the inverter and motor. Please observe the manufacturer's specifications.
- Inductances of relays, contactors, solenoid valves or brakes should be wired with suppressors. To prevent conducted interference coupling, this is necessary for relays or contactors that are connected directly to the inputs or outputs (IO). To prevent interference coupling via the air path, this also applies to all inductances in the near field of the installation. Suppressors must be connected directly to the coil: RC elements or varistors for operation with alternating current (AC) and freewheeling diodes or varistors for operation with direct current (DC), whereby freewheeling diodes are preferable.
- The UOM(H) 4L-1212 is operated with low voltage of up to 30 V. To avoid interference coupling via the air path, it is important to plan cable routes with sufficient distance to power lines in accordance with the following diagram. This generally applicable diagram is to be used for all connections **inside** and **outside** control cabinets.

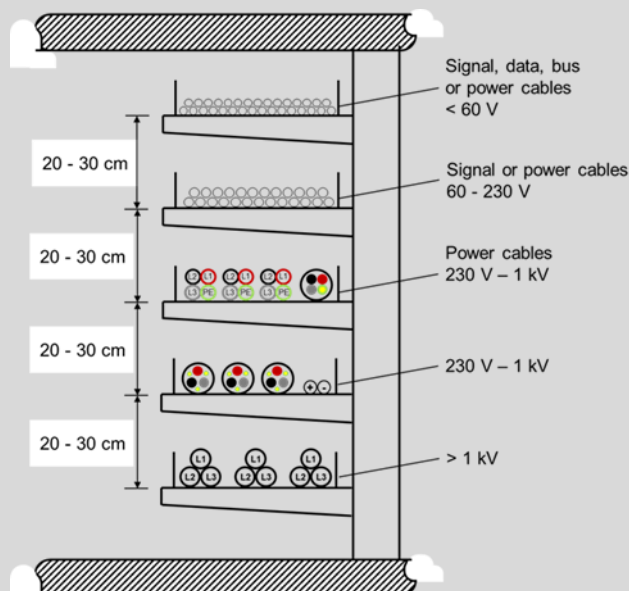

Figure : Scheme for planning cable routes

#### 4.10.2 Connecting



- Sufficient dimensioning of the power supply.
- The conductor cross-section of the power supply cable must be designed so that the maximum voltage drop is less than 3 V. A wire cross-section of 0.75 mm<sup>2</sup> is recommended. Permissible cable diameter: 8 - 5 mm.  
(Cable diameter for UL-listed devices 8 - 7 mm).
- A DC distribution network can comprise considerable cable lengths, which may be subject to interference. It is recommended that the UOM(H) 4L-1212 is not operated on a heavily disturbed DC distribution network. If necessary, a separate power supply should be provided. To minimize interference, the DC distribution should be connected to the power supply unit in a star configuration and with symmetrical routing of the forward and return conductors (as a “twisted pair” or as a cable).
- A shielded supply cable must be used for the electrical connection. The cable shield must be connected to the machine grounding on both sides. Shield connection terminals must be used to connect the cable shielding to a large surface area in the switch cabinet. The same applies to the shielding of signal cables.
- A cable for connecting to ground potential must be connected to the ground terminal of the UOM(H) 4L-1212, if not already pre-assembled (max. tightening torque 2.0 Nm).
- A flat grounding strap consisting of fine stranded wire with a minimum cross-section of 6 mm<sup>2</sup> must be used for grounding.
- The grounding strap must be permanently and permanently connected to a low-impedance, nearby grounding point on the system side. The grounding point must be bare metal, free of paint, non-conductive surface finishes, grease, oil and corrosion. The length of the grounding strap should not exceed 2 m.

#### 4.10.3 Connecting the fiber optic cable

The fiber optic cable is inserted into the terminal box of the UOM(H) 4L-1212 via the second cable gland and is connected to a ST plug at the fiber optic output. Several sealing inserts for different cable diameters are included with the basic unit for the FO cable gland. The outer sheath of the fiber optic cable must be firmly seated in the sealing insert of the cable gland.

In the terminal box, the fiber optic cable without an outer sheath must be laid in a loop without kinks.



Figure: Fiber optic cable and supply cable in the terminal box of the UOM(H) 4L-1212

For fixed cable installations, either a non-slotted or a slotted sealing insert in the sizes 2 x 3 mm, 1 x 5...8 mm, 1 x 7...10.5 mm can be used in the cable gland of the fiber optic cable. The non-slotted sealing insert requires a tool to fit the ST plug due to the narrow internal diameter. Slotted sealing inserts enable device installation with pre-assembled fiber optic cables.



#### **ATTENTION!**

UL-/CSA-conformity is only given for the non-slotted sealing insert (pre-assembled). When using a slotted sealing insert (enclosed), the UL-/CSA test mark must therefore be covered with the enclosed sticker.

## 4.11 Dismantling

### 4.11.1 Safety instruction

#### Personnel

Dismantling must be carried out by qualified personnel only.



#### WARNING!

Observe the safety instructions contained in **Chapter 2** when dismantling the device!



#### NOTES!

Do not use a hammer or similar tool when installing the device due to the risk of damage occurring to the bearings or coupling!

### 4.11.2 Dismantling the universal encoder type B5 and B35

To dismantling the universal encoder, follow the instructions given in Chapters 4.5 and 4.6 in the reverse order.

### 4.11.3 Dismantling hollow shaft type

Dismantle the hollow shaft device follow the instructions in Chapter 4.9 in the reverse order.

## 4.12 Electrical / fiber optic connection and commissioning



#### NOTES!

You must observe applicable EMC guidelines when routing cables!

#### 4.12.1 Electrical / fiber optic connection

1. Open the terminal box cover (16, Fig. 1:)



**CAUTION!**

Do not allow moisture to enter the terminal box when the cover is open!

2. Remove the cable gland sealing bolt (17, Fig. 1:)
3. Feed the cable into the terminal box through the cable gland.
4. Tighten the cable gland using a spanner.



**NOTES!**

Prior to delivery cable glands and blanking plugs are tightened finger tight only. To ensure that the terminal box is reliably sealed tighten all cable glands and blanking plugs before starting up for the first time.

5. Use a spanner to tighten the cable gland until the cable is securely clamped and properly sealed.



**NOTES!**

Prevent lateral pulling forces acting on the cable and plugs so as not to impair the degree of protection of the cable gland.

6. Connect the supply voltage and fiber optic cables



**CAUTION!**

Exercise care when operating the actuation rocker of the PCB terminal. Carefully plug in the ST connector paying attention to connector coding!

#### connection diagram EL 667b

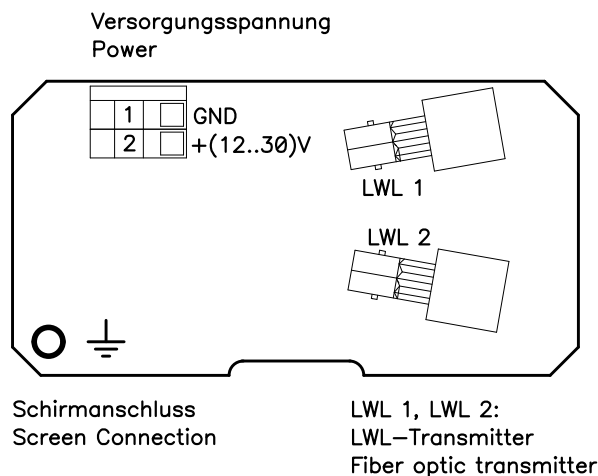

7. Close the terminal box cover.



**NOTES!**

Before closing the terminal box cover check and if necessary clean both seal surfaces and the gasket.



**CAUTION!**

Ensure when closing the terminal box cover that no cable becomes jammed.



**NOTES for UL and CSA!**

Do only use copper cables



### 4.13 Intended us

The system manufacturer must check that the characteristics of the measuring system satisfy his application-specific safety requirements. The responsibility or decision regarding the use of the measuring system lies with the system manufacturer.

**For UL and CSA:** For the use in NFPA 79 applications only.

**Intended use also includes:**

- observing all instructions in this operating and assembly instructions
- observing the nameplate and any prohibition or instruction symbols on the device
- observing the operating instructions from the machine/system manufacturer
- operating the measuring system within the limit values specified in the technical data
- ensuring that the fail-safe processing unit (F-Host) fulfils all required safety functions
- safe mounting (form-closed) of the measuring system to the driving axis

### 4.14 Improper use



**Warning:**

This device is not intended for use in residential areas and cannot ensure adequate protection of radio reception in such environments.

- Do not use the device in potentially explosive areas.
- The device must not be used for medical purposes.
- The device must not be subjected to mechanical loads in addition to its own weight and unavoidable vibration and shock loads that arise during normal operations.

Examples for non-permitted mechanical loads (incomplete list):

- Fastening transport or lifting tackle to the device, for example a crane hook to lift a motor.
  - Fastening packaging components to the device, for example ratchet straps, tarpaulins etc.
  - Using the device as a step, for example by people to climb onto a motor.
- It is not permitted to use the device in locations higher than 3000 m above sea level.

### 4.15 Inspections

#### 4.15.1 Safety advice for personnel



**WARNING!**

Skilled technical staff only are permitted to inspect the device and its installation. Observe the safety instructions contained in **Chapter 2** when inspecting or working on the device!

#### 4.15.2 Maintenance information

The device is maintenance-free. However, to guarantee optimum fault-free operations we recommend that you carry out the following inspections.

Qualified personnel only are permitted to carry out the inspection work described here. In particular, we remind you that you must observe and adhere to all operating and owner-relevant accident prevention regulations, laws regarding the safeguarding of machinery and plant as well as application and country-specific regulations, laws and standards.

#### 4.15.3 Inspection schedule



**NOTES!**

No other actions are required to be carried out on the device in addition to the following cyclical inspections described in this inspection schedule. Any attempt to tamper with the device will result in the warranty being rendered null and void!

Interval	Inspections
Yearly	Inspect the coupling for damage and absence of play
	Ensure all fastening screws are properly tightened
	Ensure cable connections and connection terminals are properly tightened
	Check the torque bracket (applies to hollow shaft devices only): check link heads can move freely. You must be able to turn the link rod manually. If it proves difficult to move, lightly oil the link rod heads or apply lubricant spray.
Following approx 16 000 – 20 000 hours of operation / higher levels of continuous load	Check deep groove ball bearings for noise, running smoothly. Bearings must be replaced by the manufacturer only.

#### 4.16 Fault table

Fault	Possible cause	Remedy
Moisture in the terminal box	Soiled gasket or seal surfaces of terminal box cover	Clean gasket of terminal box cover and seal surfaces
	Gasket of terminal box cover damaged	Replace gasket of terminal box cover
	Cable gland/blanking plug not tightened	Tighten cable gland/blanking plug
	Unsuitable cable for cable gland	Use suitable cable and cable glands

Contact Hübner-Service (page 2) if none of the actions listed above provide a solution!

## 5 Replacement parts

The replacement parts listed below can be obtained via the service address on page 2.

Replacement Part	Comment
Cover	Cover for the 2 <sup>nd</sup> shaft end or for the hollow shaft bore (NDE)
Axial tensioning disk/ring	For hollow shaft design
Terminal box – screw plug	To seal unused cable gland threads
Cable gland	M20x1,5
Terminal box cover	Including flat seal and screws
Feather key	Specify shaft dimensions or feather key dimensions
Programming cable and software	
Screw plug M12x1,5	To close of the access to the coupling



**NOTES!**

When ordering replacement parts always specify the serial number of the device!

## 6 Transport, packaging and storage

### 6.1 Safety information concerning transport



**CAUTION!**

**Material damage caused by improper transport!**

Observe the symbols and information on the packaging:

- Do not throw - risk of breakage
- Keep dry
- Do not expose to heat above 40 °C or direct sunlight.

### 6.2 Goods inward inspection

Check the delivery immediately upon receipt for transit damage or short delivery.

Inform the carrier immediately on receipt if you determine that damage has occurred during transit (take photos as proof).

### 6.3 Packaging (disposal)

The packaging is not taken back; dispose of according to the respective valid statutory provisions and local regulations.

### 6.4 Storing packages (devices)



**Keep dry**

Keep packages dry and free from dust; protect from moisture.

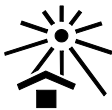

**Protect against heat**

Protect packages from heat above 40 °C and direct sunlight.

If you intend to store the device for a longer period of time (> 6 months) we recommend you use protective packaging (with desiccant).



**NOTES!**

Turn the shaft of the device every 6 month to prevent the bearing grease solidifying!

### 6.5 Returning devices (repairs/goodwill/warranty)

Devices that have come into contact with radioactive radiation or radioactive materials are not taken back.

Decontaminate devices that have may come into contact with harmful chemical or biological substances before returning.

They must also be accompanied by a safety clearance certificate.

### 6.6 Disposal

The manufacturer is not obliged to take back the device.

The device is classed as electronic equipment and subject to the WEEE Directive; observe local, country-specific laws when disposing of the device.

For information on environmentally sound disposal please contact your local authority or a specialist disposal company.