

Operating and Assembly Instructions

Incremental hollow shaft encoder FGJ 5

**Read the Operating and Assembly Instructions prior to assembly, starting installation and handling!
Keep for future reference!**

Trademark

Brand names and product names are trademarks or registered trademarks of their respective owner. Protected trademarks bearing a TM or ® symbol are not always depicted as such in the manual. However, the statutory rights of the respective owners remain unaffected.

Manufacturer / publisher

Johannes Hübner
Fabrik elektrischer Maschinen GmbH
Siemensstraße 7
35394 Giessen
Germany
Phone: +49 641 / 7969-0
Fax: +49 641 / 73645
E-Mail: info@huebner-giessen.com
www.huebner-giessen.com

The manual has been drawn up with the utmost care and attention. Nevertheless, we cannot exclude the possibility of errors in form and content. It is strictly forbidden to reproduce this publication or parts of this publication in any form or by any means without the prior written permission of Johannes Hübner Fabrik elektrischer Maschinen GmbH
Subject to errors and changes due to technical improvements.

Copyright © Johannes Hübner
Fabrik elektrischer Maschinen GmbH
All rights reserved.

Directory

1	General	5
1.1	Information about the operating manual	5
1.2	Scope of delivery	5
1.3	Explanation of symbols	5
1.4	Disclaimer	6
1.5	Copyright.....	6
1.6	Guarantee terms.....	6
1.7	Customer service.....	6
2	Safety.....	6
2.1	Responsibility of the owner.....	6
2.2	Intended use	6
2.3	Non- intended use	7
2.4	Personal protective equipment	7
2.5	Personnel.....	7
2.6	Special dangers	7
2.6.1	Electrical current.....	7
2.6.2	Rotating shafts / Hot surfaces.....	7
2.6.3	Safeguarding against restart.....	7
3	Technical Data	8
3.1	Type plate	8
3.2	Electrical and mechanical data	8
3.3	Type code	11
4	Transport, packaging, and storage	12
4.1	Instruction for transport.....	12
4.2	Goods inward inspection	12
4.3	Packaging (disposal)	12
4.4	Storing packages (devices)	12
5	Installation and commissioning.....	13
5.1	Safety instructions	13
5.2	Mounting of the encoder (mechanically).....	13
5.2.1	Assembly instruction for hollow shaft devices	13
5.3	Connecting the encoder.....	15
5.3.1	Connections	15
5.3.2	Technical notes	15
6	Disassembly.....	16
6.1	Safety instructions	16
6.2	Disassembly of the encoder	16
7	Troubles	17
7.1	Troubles table	17
8	Inspections.....	18
8.1	Safety instructions	18

8.2	Maintenance information	18
8.3	Inspection schedule	18
9	Disposal.....	18
10	Dimension drawings.....	19
11	Connection Diagrams.....	23

1 General

1.1 Information about the operating manual

These Operating and Assembly Instructions provide important instructions for working with the device. They must be carefully read prior to starting all tasks, and the instructions contained herein must be followed.

In addition, applicable local regulations for the prevention of industrial accidents and general safety regulations must be complied with.

1.2 Scope of delivery

Hollow shaft encoder FGJ 5, Operating and Assembly Instructions.

1.3 Explanation of symbols

Warnings are indicated by symbols in these Operating and Assembly Instructions. The warnings are introduced by signal words that express the scope of the hazard.

The warnings must be strictly heeded; you must act prudently to prevent accidents, personal injury, and property damage.



WARNING!

Indicates a possibly dangerous situation that can result in death or serious injury if it is not avoided.



CAUTION!

Indicates a possibly dangerous situation that can result in minor injury if it is not avoided.



CAUTION!

Indicates a possibly dangerous situation that can result in material damage if it is not avoided.



NOTES!

Indicates useful tips and recommendations as well as information for efficient and trouble-free operation.



NOTES!

Do not use a hammer or similar tool when installing the device due to the risk of damage occurring to the bearings or coupling!



DANGER!

Life-threatening danger due to electric shock!

Indicates a life-threatening situation due to electric shock. If the safety instructions are not complied with there is danger of serious injury or death. The work that must be executed should only be performed by a qualified electrician.

1.4 Disclaimer

All information and instructions in these Operating and Assembly Instructions have been provided under due consideration of applicable guidelines, as well as our many years of experience.

The manufacturer assumes no liability for damages due to:

- Failure to follow the instructions in the
- Non-intended use
- Deployment of untrained personnel
- Opening of the device or conversions of the device

In all other aspects the obligations agreed in the delivery contract as well as the delivery conditions of the manufacturer apply.

1.5 Copyright



NOTES!

Content information, text, drawings, graphics, and other representations are protected by copyright and are subject to commercial property rights.

It is strictly forbidden to make copies of any kind or by any means for any purpose other than in conjunction with using the device without the prior written agreement of the manufacturer. Any copyright infringements will be prosecuted.

1.6 Guarantee terms

The guarantee terms are provided in the manufacturer's terms and conditions.

1.7 Customer service

For technical information personnel are available that can be reached per telephone, fax, email, or via the Internet, see manufacturer's address on page 2.

2 Safety



DANGER!

This section provides an overview of all the important safety aspects that ensure protection of personnel, as well as safe and trouble-free device operation. If these safety instructions are not complied with significant hazard can occur.

2.1 Responsibility of the owner

The device is used in commercial applications. Consequently the owner of the device is subject to the legal occupational safety obligations and subject to the safety, accident prevention and environmental protection regulations that are applicable for the device's area of implementation.

2.2 Intended use

The device has been designed and constructed exclusively for the intended use described here.

Series FGJH 5 hollow shaft encoders are used for measurement of rotations, for instance of electrical and mechanical drives and shafts.

Claims of any type due to damage arising from non-intended use are excluded; the owner bears sole responsibility for non-intended use.

2.3 Non- intended use

The device may not be used in explosion-threatened areas.

On the device no other mechanical load may be exercised except his dead weight and the oscillations without fail appearing during the company and pushes.

Examples of inadmissible mechanical charges (incomplete listing):

- Connection of transport or lifting means in the device, e.g., load hook for raising of an engine.
- Connection of packaging parts in the device, e.g., instep belts, tarpaulin, etc.
- Use of the device as a step, e.g., for going up of a person on an engine.

2.4 Personal protective equipment

For tasks such as assembly, disassembly or commissioning the use of personal protective equipment such as safety footwear and protective work clothing is required.

The regulations specified by the owner and that are locally specified apply.

2.5 Personnel

Only trained, specialized personnel is allowed to perform installation, mounting, disassembly and commissioning work.

2.6 Special dangers

Residual risks that have been determined based on a risk analysis are cited below.

2.6.1 Electrical current



DANGER!

Life-threatening danger due to electrical shock!

There is an imminent life-threatening hazard if live parts are touched. Damage to insulation or to specific components can pose a life-threatening hazard.

Therefore:

Immediately switch off the device and have it repaired if there is damage to the insulation of the power supply.

De-energize the electrical equipment and ensure that all components are connected for all tasks on the electrical equipment.

Keep moisture away from live parts. Moisture can cause short circuits.

2.6.2 Rotating shafts / Hot surfaces



WARNING!

Danger of injury due to rotating shafts and hot surfaces!

Touching rotating shafts can cause serious injuries.

Therefore:

Do not reach into moving parts/shafts or handle moving parts/shafts during operation.

Close to protect from injury all access openings in flanges with the corresponding plug screw, and provided you exposed rotating components with protective covers.

Do not open covers during operation. Prior to opening the covers ensure that all parts have come to a standstill.

The encoder can become hot during prolonged use.

In case of contact risk of burns is existing.

2.6.3 Safeguarding against restart



DANGER!

Life-threatening danger if restarted without authorization!

When correcting faults there is danger of the power supply being switched on without authorization.

This poses a life-threatening hazard for persons in the danger zone.

Therefore:

Prior to starting work, switch off the system and safeguard it from being switched on again.

3 Technical Data

3.1 Type plate

Type plate example:



The type plate and UKCA label are located on the side of the housing.

Type plate information:

- Manufacturer, Address, CE-mark
- Type
- Serial number (S/N)
- Date of manufacturing (Y)
- Number of pulses (PPR)
- Degree of protection (IP)
- Supply
- Output
- ID number
- QR-code

3.2 Electrical and mechanical data

Pulse rates	Account
Preferred pulse rates (nickel disks)	1024, 2000
Pulse rates available	512, 1000, 1200, 1800, 2048, 2500

Connection data	
Supply voltage	12 ... 30 V DC (Option: 5 VDC)
No load-current	approx. 100 mA at 30 V (without Option)
Outputs	Differential line-driver, resistant to sustained short-circuit, current limited, short-circuit.
Pulse height (HTL)	approx. as supply voltage
Internal resistance	50 Ω per output
Pulse height (TTL)	5 V to RS 422
Slew rate	50 V / μs

Pulse duty factor	1 : 1 ± 5 %
Square wave displacement 0°, 90°	to 50 KHz < 3 % to 150 KHz < 5 %
Max. frequency	0 to 100 kHz. (to 150 kHz on request)
Encoder temperature ranges	
Standard	0°C ... + 70°C
Special temperature	-25°C... + 85°C
Special output voltage 5V (TTL)	
Pulse height	5V, RS422 compatible (TIA/EIA-Standard)
Supply voltage	12 ... 30 V DC

Protection class DIN EN 60529	Sealing	Mechanical speed	Description	Breakaway torque
IP 66 only AS	Radial shaft seal	≤ 1200 rpm	Protection against dust and water spray	approx. 56...60 Ncm
IP 66 both sides	Radial shaft seal	≤ 1100 rpm	Protection against dust and water spray	approx. 70 Ncm

Weight	Type K	7,5 kg
--------	--------	--------

Signal outputs																			
<p>Basic version (n = pulses / revolution). One pulse channel (basic) with n direct square wave pulses, corresponding to the segment division and LED monitoring output. (optional).</p>																			
<p>Option 90 2nd pulse channel as basic version, but with 90° electrical phase shift.</p>																			
<p>Option N / N2 Marker pulse, mechanically fixed. One square wave pulse per revolution.</p>																			
<p>Option G Additional inverted output signals for basic and 90° channels, marker pulse puls LED check.</p>																			
<p>Option F With 2 or 4 times as many pulses as the basic version. No direction of motion can be derived from the multiple number of pulses. Required: option 90.</p>																			
<p>Option B Fast and precise sensing of rotational direction at each edge of the basic and 90° channels. Required: option 90.</p>	<table border="1" style="margin-left: auto; margin-right: auto;"> <thead> <tr> <th rowspan="2"></th> <th colspan="2">Output</th> <th rowspan="2"></th> </tr> <tr> <th>L</th> <th>R</th> </tr> </thead> <tbody> <tr> <td>cw</td> <td>0</td> <td>1</td> <td>Option B, B2</td> </tr> <tr> <td>ccw</td> <td>1</td> <td>0</td> <td>Option B, B2</td> </tr> <tr> <td>Stillstand</td> <td>0</td> <td>0</td> <td>Option B2</td> </tr> </tbody> </table>		Output			L	R	cw	0	1	Option B, B2	ccw	1	0	Option B, B2	Stillstand	0	0	Option B2
	Output																		
	L	R																	
cw	0	1	Option B, B2																
ccw	1	0	Option B, B2																
Stillstand	0	0	Option B2																
<p>Option B2 As option B, but with standstill sensing..</p>																			
<p>Option V Electronic pulse doubling of basic and 90° channels by multiple evaluation.</p>																			
<p>Option L2 Power output up to 150 mA for basic channel, 90° channel and the corresponding inverted signals.</p>																			
<p>Option J Reduced rotational frequency modulation by means of optically adjusted pulse disk.</p>																			

3.3 Type code

	FGH	J	5	K	1024	G	90G	NG	2F	J	40P
Incremental hollow shaft encoder											
Encoder with isolated bearings											
Series											
Connection method											
K: Terminal box											
S: EMC industrial plug											
R: 12-pol. round plug											
C: 2 m cable connection											
L: Fibre optic connection											
Pulses per revolution											
1024, 2048											
Basic signal output											
Basic channel 0° (A)											
Pulse channel 90° (B)											
Each with inverted signals											
NG: Option reference pulse with inverted signal											
2F: Option 2F											
4F: Option 4F											
B: Option B											
B2: Option B2											
V: Option V											
J: Option J (J can be combined with V)											
Hollow shaft bore											
Only with hollow shafts											
Ø 40											
Drive shaft connection											
P: feather key											

4 Transport, packaging, and storage

4.1 Instruction for transport



CAUTION!

Material damage caused by improper transport!

Observe the symbols and information on the packaging:

- Do not throw - risk of breakage
- Keep dry
- Do not expose to heat above 40 °C or direct sunlight.

4.2 Goods inward inspection

Check the delivery immediately upon receipt for transit damage or short delivery.

Inform the carrier immediately on receipt if you determine that damage has occurred during transit (take photos as proof).

4.3 Packaging (disposal)

The packaging is not taken back and must be disposed of in accordance with the respective statutory regulations and local guidelines.

4.4 Storing packages (devices)



Keep dry

Keep packages dry and free from dust; protect from moisture.

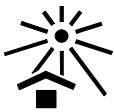

Protect against heat

Protect packages from heat above 40 °C and direct sunlight.

If you intend to store the device for a longer period of time (> 6 months) we recommend you use protective packaging (with desiccant).



NOTES!

Turn the shaft of the device every 6 month 10 times to prevent the bearing grease solidifying, which may lead to the destruction of the device.

5 Installation and commissioning

5.1 Safety instructions

Personnel

Only trained, specialized personnel should perform installation and commissioning work.



Observe safety instructions of **chapter 2** before starting any tasks (installation/testing).

5.2 Mounting of the encoder (mechanically)

Mounting and disassembly by means of a hammer or similar tools is not permitted (warranty void).

5.2.1 Assembly instruction for hollow shaft devices

1. Mount the adapter flange and align precisely with dial gauge; if necessary optimize the alignment with ball pressure adjusting screws.
2. Secure the ball pressure screws with Loctite. Remove pressure screws that are not used, or likewise secure them with a thread-lock lacquer.

Max. tightening torque for M12 approximately 24 Nm; for M16 approximately 63 Nm.



Abb. 1



Abb. 2

The hollow shafts have tapped holes on both sides at the front. For removal use screws to attach the mounting sleeve, and use a puller to draw off the unit. A suitable mounting sleeve is recommended for each plant area (specify on ordering).

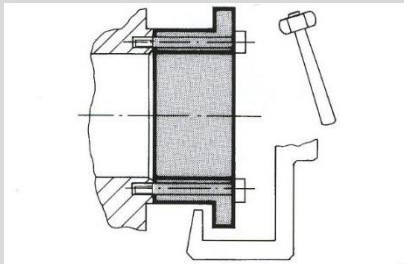
Mount hollow shaft encoders using mounting sleeve only.

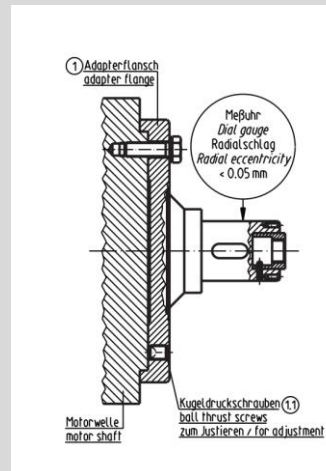

NOTE!

The radial deviation of the shaft (\Leftrightarrow Fig. 2 Pos. 1) should not exceed 0,05 mm.

3. Use feather keys in accordance with DIN 6885.

4. Mount the torque bracket/torque arm on the housing.



NOTE!

Comply with the information provided in the supplemental data sheet entitled "Mounting Accuracy of hollow shaft encoders".

5. Check the mounting position relative to the terminal box, adjust if necessary.
6. Push the device onto the shaft that has been lightly greased.



CAUTION!

Danger of damage to shaft and device if improperly handled.

Ensure that there are no hard impacts on hollow shaft and housing.
Use the mounting sleeve.

7. Fastening Axial tightening disc with 4x M4 on the adapter shaft.
8. Tighten the fastening screws on the link head of the torque bracket. Fix the nuts in place with locknuts.
9. Check the attached torque brackets: The link rod must be easy to turn within the link head, and the link heads should not tilt. If this instruction is not followed there is a danger of bearing damage.
10. Connect the cabling in the terminal box (see connecting diagrams, chapter 11).

5.3 Connecting the encoder

5.3.1 Connections

Cable glands are closed with a stopper to protect the devices on transport and storage.

Cable connections:

Have to be executed according to the encoder type.

Connection diagrams have to be considered!

See chapter 11 and in the terminal box cover. To fulfil degree of protection requirements the diameter of the connection cable must correspond to that of the cable gland (please refer to Chapter 10, Dimension drawings). Cable outlet should show preferably downwards.

Option:

R: 12 – pole round plug

S: EMC industrial plug

C: Connection cable

Wiring arrangement and shielding:

(EMC measurement)

The cable shielding to be connected on both ends.

The shield of the signal cable can be connected directly to the housing of the encoder by the cable gland.

The common guidelines for EMC concerned cable routing have to be considered!

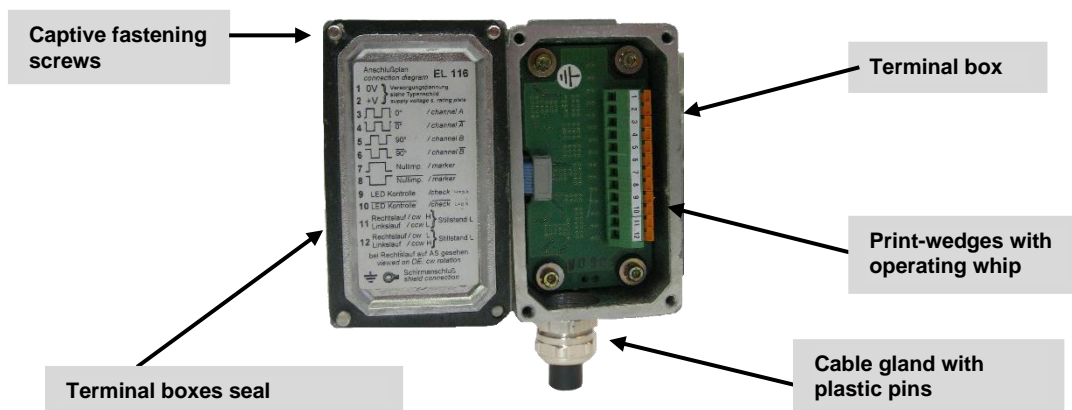

Important instruction!

Competent persons may only connect the encoder.

Closing the terminal box cover

Check the seal of the terminal box cover, clean it if soiled. Then duly close the cover.



Cable must not be pinched

Attention with open terminal boxes.

Moisture should not get into the terminal box when connecting the cable.

5.3.2 Technical notes

Ambient temperature

The max. perm. ambient temperature depends on speed and protection class (shaft sealing) of the encoder as well as on frequency, signal cable length and mounting situation. See chapter 3.2.

Protection class

To comply with the protection class the signal cable diameter must be appropriate to the cable gland! See chapter 5.3.1.

6 Disassembly

6.1 Safety instructions



Personnel

Dismantling must be carried out by skilled technical staff only.

Attention: Observe safety instructions 2 before starting any tasks. (Installation/maintenance/disassembly).

6.2 Disassembly of the encoder

Disassembly of the hollow shaft encoder has to be done in reverse sequence.

For short adapter shafts the disassembly with the dismantling device can be done completely.

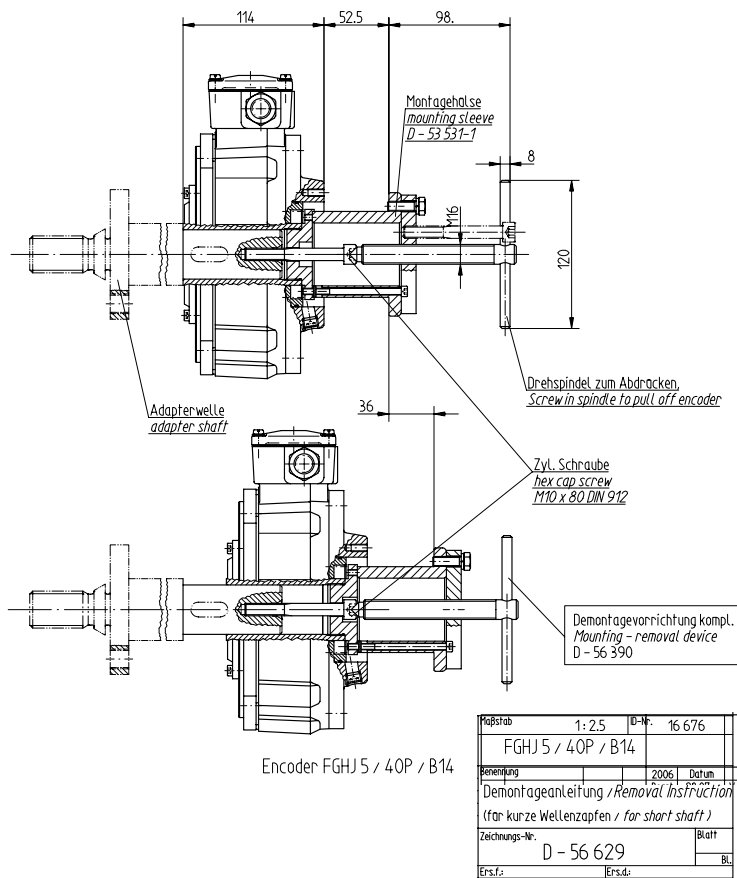

Maßstab	1:2,5	D-Nr.	16 676
FGJ 5 / 40P / B14			
Genehmigung		2006	Datum
Demontageanleitung / Removal instruction (for kurze Wellenzapfen / for short shaft)			
Zeichnungs-Nr.	D - 56 629		Blatt
Ers.f.		Ers.d.	Bl.

7 Troubles

7.1 Troubles table

Malfunction	Possible cause	Trouble shooting
Moisture in the terminal box	Seal of terminal box cover Cable gland Cable dia too small	Contact Hübner Service Check by specialized personnel Change cables
No output signals	No supply voltage Mixed connection cables	Connect supply voltage Check polarity
Disturbed output signals	Improper control cable shield not connected	Use data cables, pairwise drilled and common shielded
Missing output signals	Ouptut stages overloads Short – circuit of output signals	Check connections Check with connection diagram

Hübner – Service address see page 2

8 Inspections

8.1 Safety instructions



Personnel

Dismantling must be carried out by skilled technical staff only.

Attention: Observe safety instructions 2 before starting any tasks.
(Installation/maintenance/disassembly).

8.2 Maintenance information

The device is maintenance free. However the following tests are recommended to ensure optimal, problem free operation.

8.3 Inspection schedule

Interval	Tests	Tasks
Every 12 month	Check coupling	Qualified person
Every 12 month	Check the fastening screws for firm seat	Qualified person
Every 12 month	Check the cable connections	Qualified person
After approx. 16000 to 20000 operating hours and high long-term loading	Check deep-groove ball bearing for ease of movement and noise.	Qualified person
	Worn ball bearings have to be replaced only by the Manufacturer	Hübner – Giessen Service

9 Disposal

The manufacturer is not obligated to take back electronics waste. The device consists of hybrid components, and in part must be disposed of as special waste (electronic scrap) according to country-specific legislation.

Local municipal authorities or specialized disposal companies provide information on environmentally responsible disposal.

10 Dimension drawings

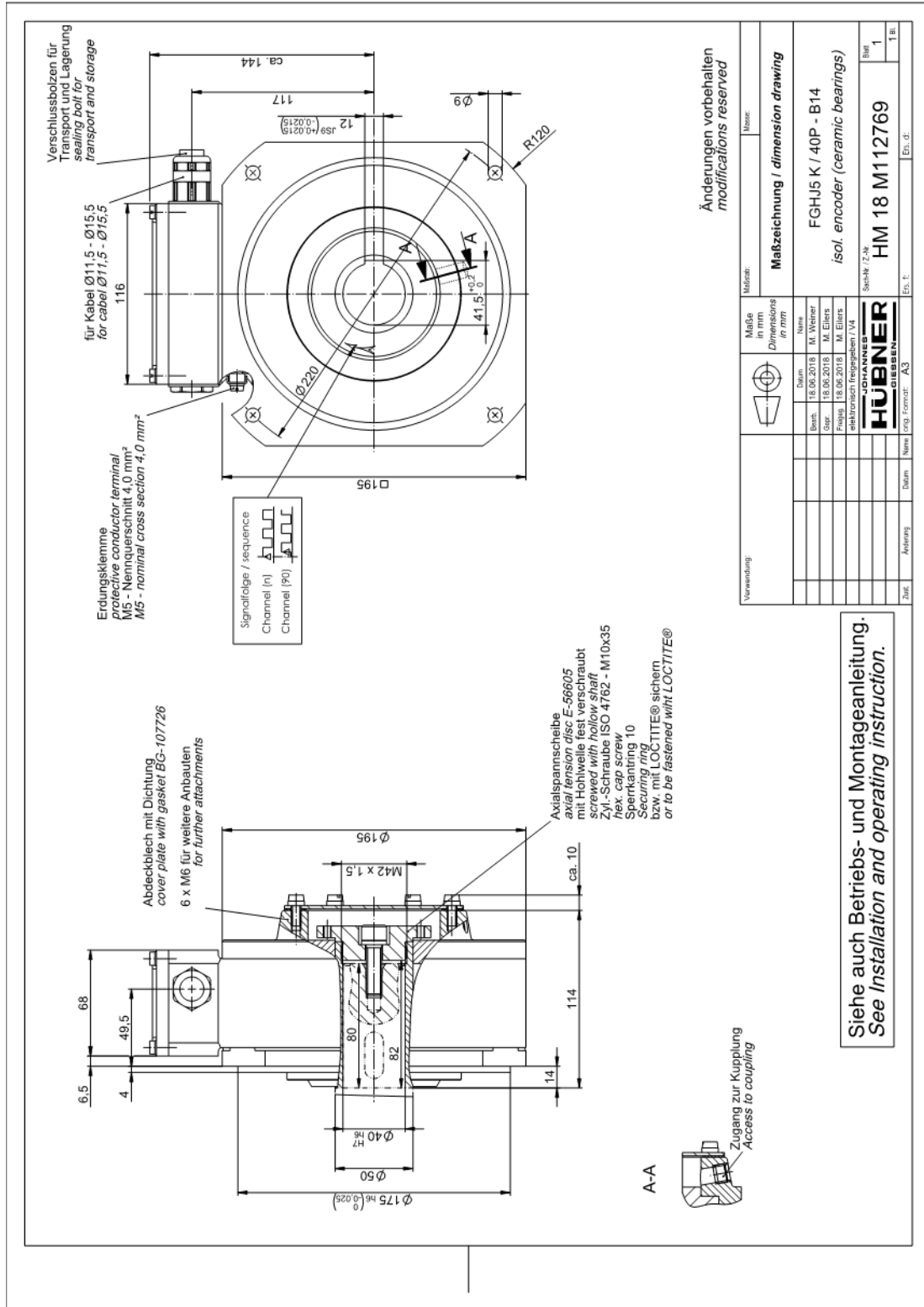

FGJ 5 K... 40P/ B14

HM 18 M 112769

Incremental Hollow Shaft Encoder FGJH 5

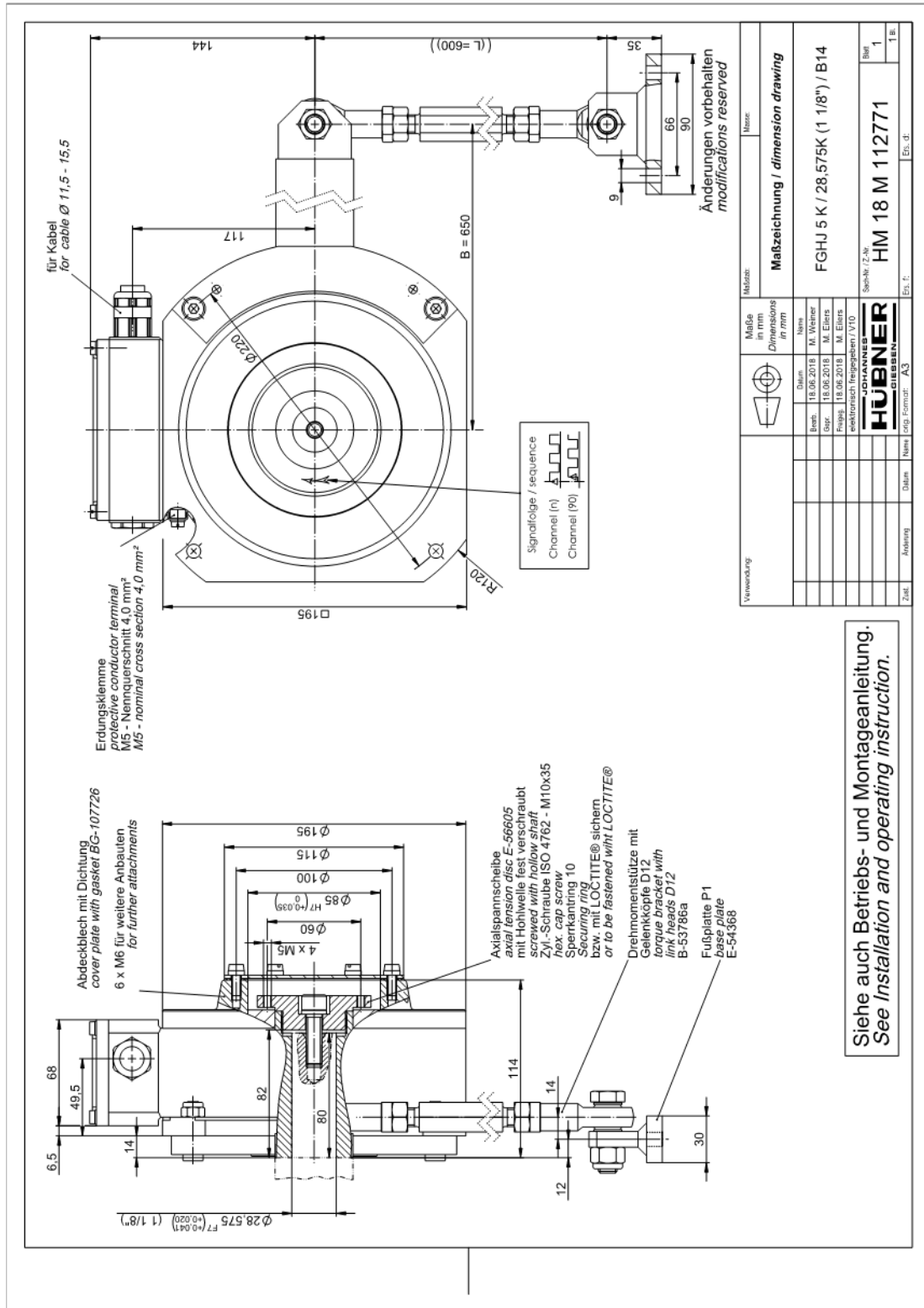

FGJH 5 K/28,575K (1 1/8")

HM 18 M 112771

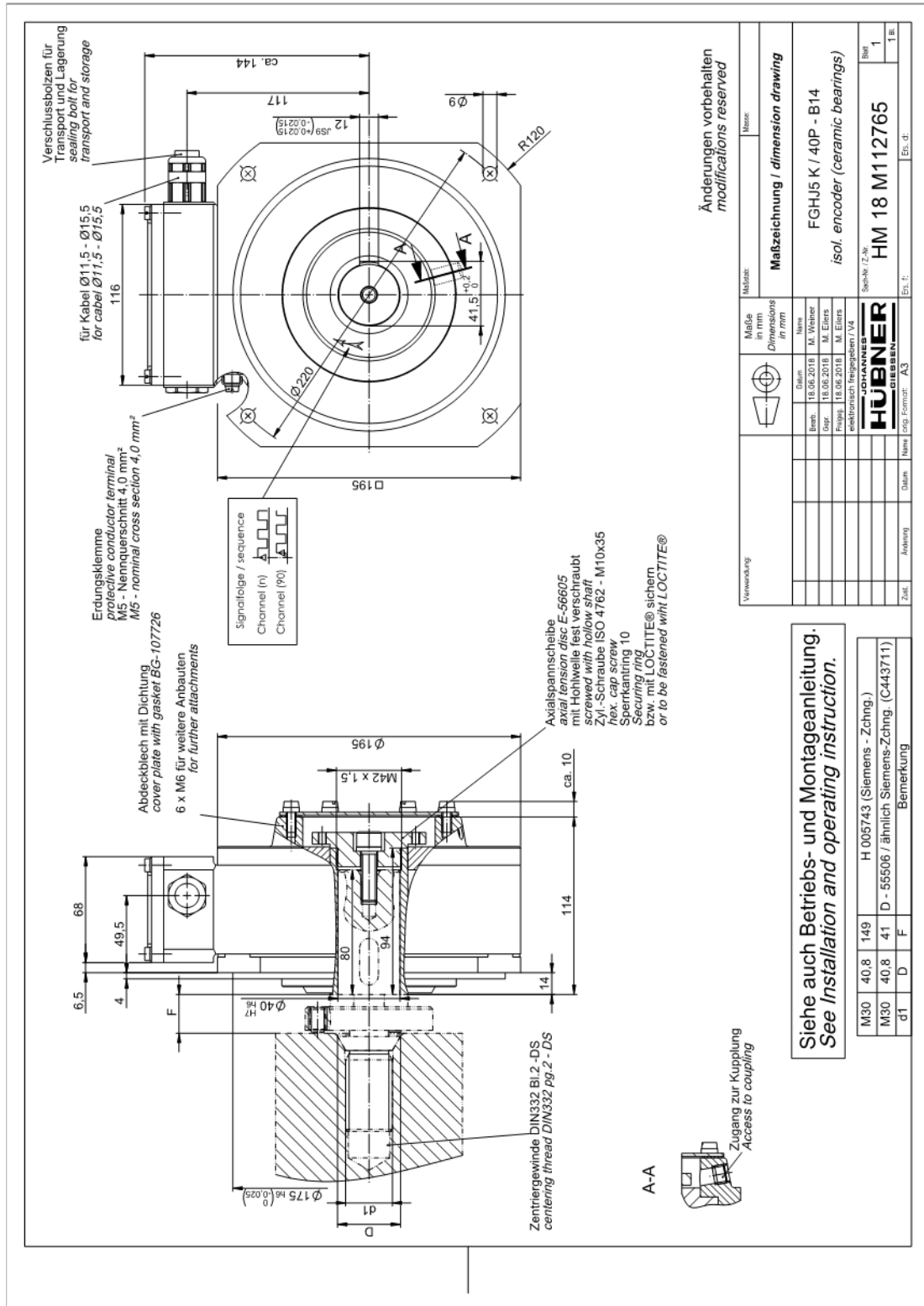

FGJ 5 K/40P/B14

HM 18 M 112765

11 Connection Diagrams

12-pol. Bandklemme Typ Phoenix
12-pole strip clamping type Phoenix

Schirmung:
Der Schirm der Signalleitung ist über die Kabelverschraubung direkt mit dem Gehäuse verbunden.
Shield:
The shield of the signal cable is directly connected with the housing of the encoder by the cable gland.

	EL 816	EL 816-1	EL 816-2	EL 816-3	EL 816-4	EL 816-5	EL 816-6	EL 816-7
OV	1	1	1	1	1	1	1	1
+ ... V ¹⁾	2	2	2	2	2	2	2	2
0'	3	3; 7	3	3	3	3	3	3
0̄'	4	4; 8	4	4	4	4	4	4
90'	5	5; 9	5	5	5	5	5	5
90̄'	6	6; 10	6	6	6	6	6	6
N	7	---	---	7	7	7	---	7
N̄	8	---	---	8	---	8	---	8
M	9	11	9	9	8	9	9	---
M̄	10	12	10	10	---	10	10	---
2F	---	---	7	11	9	---	---	11
4F	---	---	8	12	10	---	7	12
4F̄	---	---	---	---	---	---	8	---
R	11	---	11	---	11	---	11	9
L	12	---	12	---	12	---	12	10
Schaltgang 1	---	---	---	---	---	11	---	---
Schaltgang 2	---	---	---	---	---	12	---	---

+ ... V¹⁾ Versorgungsspannung nach Typenschildangabe
supply voltage see rating plate

Verwendung: FG .. (A)K

Allgemeintoleranzen DIN ISO 2768m

OFZ nach DIN ISO 1302

Maßstab:

Werkstoff:

Datum: 03.06.14

Name: Diriam

Benennung: Anschlussplan
Connection diagram

Zeichnungs Nr.: EL 816

Blatt: Bl.

z.B. e.g.: FG.K-1000 G - 90 G - N G

0' channel A
0' inv. channel A inv.
90' channel B
90' inv. channel B inv.
Nullimpuls marker
Nullimp. inv. marker inv.

FGJ 5

Standard

Terminal box

Anschlusskabel direkt angelötet
6x2x0,56 paarig verseilt, geschirmt

Connection cable soldered-on directly
6x2x0,56 twin-stranded, shielded

rot red — + (12 - 30)V } Versorgungsspannung
schwarz black — 0V } supply voltage

orange orange — 0' / channel A
schwarz black — 0' inv. / channel A inv.

blau blue — 90' / channel B
schwarz black — 90' inv. / channel B inv.

gelb yellow — Nullimpuls / marker
schwarz black — Nullimpuls inv. / marker inv.

grün green — LED Kontrolle / check H = o.k.
schwarz black — LED Kontrolle inv. / check inv. L = o.k.

braun brown — Rechtslauf / cw H } Stillstand L
schwarz black — Linkslauf / ccw L }
Rechtslauf / cw L } Stillstand L
Linkslauf / ccw H }

Schirm ist mit Gehäuse verbunden
shield is connected to casing
alternativ/alternative
Der Schirm der Signalleitung ist über die Kabelverschraubung direkt mit dem Gehäuse verbunden.
The shield of the signal cable is directly connected with the housing of the encoder by the cable gland.

Typ : HE-2LVCC-CY AWG 20b
VDE 0881 zugelassen
acc. to VDE 0881
Querschnitt: 0,56 mm²
cross-section
Temperatur: -30°C bis +105°C
fest verlegt
temperature
fixed installation
-10°C bis +105°C
bewegt
flexing
Außendurchmesser: 10,1 mm
Outside dia

Verwendung: FG...C

Allgemeintoleranzen DIN ISO 2768m

OFZ nach DIN ISO 1302

Maßstab:

Werkstoff:

Datum: 11.12.91

Name: Martis

Benennung: Anschlussplan
Connection diagram

Zeichnungs Nr.: EL 205

Blatt: Bl.

z.B. e.g.: FG.C-1000 G - 90 G - N G

0' channel A
0' inv. channel A inv.
90' channel B
90' inv. channel B inv.
Nullimpuls marker
Nullimp. inv. marker inv.

FGJ 5

Standard

Connection cable

Ansicht auf Steckdoseneinsatz
Socket insert view

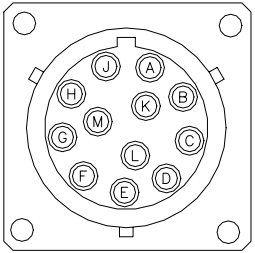

Crimpkontakte für Drahtquer-
schnitte 0,52 bis 1,5 mm²
*Crimp contacts for cross-sectional
data of wire from 0.52 up to 1.5 mm²*

Schirmung:
Der Schirm der Signalleitung ist direkt
mit dem Steckergehäuse zu verbinden.

Shield:
*The shield of the signal cable is directly
to be connected with the socket housing*

Crimpzange: Burndy Nr. MR 8 GE 5
Crimping tool: Burndy No. MR 8 GE 5

	0V	EL 161	EL 161-1	EL 161-2
	+ ... V ¹⁾	A	A	A
0°		B	B	B
0°		C	C	C
90°		D	D	D
90°		E	E	E
90°		F	F	F
N		G	G	G
N		H	H	H
M		J	J	---
M		K	K	---
2F		---	---	J
4F		---	---	K
R		L	---	L
L		M	---	M
Schaltausgang 1		---	---	---
Schaltausgang 2		---	---	---

+ ... V¹⁾ Versorgungsspannung nach Typenschildangabe
supply voltage see rating plate

Verwendung: FG .. R

Allgemein-
toleranzen
DIN ISO 2768m

OFZ nach
DIN ISO 1302

Maßstab:
Werkstoff:

Benennung:
Anschlußplan
Connection diagram

Zeichnungs Nr.: EL 161

Blatt: Bl.

Zust. Änderung Datum: Name

Die Belegung der Anschlüsse *Availability of options*
ist aus der Typen-
bezeichnung ersichtlich *see type description*

z.B. e.g.: FG.R-1000 G - 90 G - N G

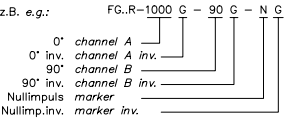

FGJH 5

Standard

12 pol. round plug

Ansicht auf Steckdoseneinsatz
Socket insert view

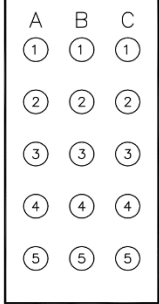

Crimpkontakte für Drahtquer-
schnitte 0,75 bis 1,0 mm²
*Crimp contacts for cross-sectional
data of wire from 0.75 up to 1.0 mm²*

Crimpzange: Harting Nr. 09 99 000 0110
Ausdrückwerkzeug: Harting Nr. 09 99 000 0012
Crimping tool: Harting No. 09 99 000 0110
Removal tool: Harting No. 09 99 000 0012

Schirmung:
Der Schirm der Signalleitung muss über
die Kabelverschraubung direkt mit dem
Gehäuse verbunden werden.

Shield:
*The shield of the signal cable has to be
connected directly to the housing of the
encoder by the cable gland.*

	0V	EL 064	EL 064-1
	+ ... V ¹⁾	C5	C5
0°		A1	A1
0°		A2	A2
90°		A3	A3
90°		A4	A4
N		B3	B3
N		B4	B4
M		B5	B5
M		C3	C3
2F		C4	C4
4F		B2	---
R		C1	C1
L		C2	C2
Schaltausgang 1		---	B1
Schaltausgang 2		---	B2

+ ... V¹⁾ Versorgungsspannung nach Typenschildangabe
supply voltage see rating plate

Verwendung: FG .. S

Allgemein-
toleranzen
DIN ISO 2768m

OFZ nach
DIN ISO 1302

Maßstab:
Werkstoff:

Benennung:
Anschlußplan
Connection diagram

Zeichnungs Nr.: EL 064

Blatt: Bl.

Zust. Änderung Datum: Name

Die Belegung der Anschlüsse *Availability of options*
ist aus der Typen-
bezeichnung ersichtlich *see type description*

z.B. e.g.: FG.S-1000 G - 90 G - N G

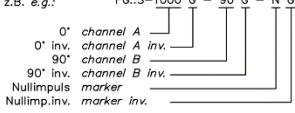

FGJH 5

Standard

EMC industrial plug