

Operating and Assembly Instructions

Incremental Hollow Shaft Encoder FGJH 2

**Read the operating and assembly instructions prior to assembly, starting installation and handling!
Keep for future reference!**

Trademark

Brand names and product names are trademarks or registered trademarks of their respective owner. Protected trademarks bearing a TM or ® symbol are not always depicted as such in the manual. However, the statutory rights of the respective owners remain unaffected.

Manufacturer / publisher

Johannes Hubner
Fabrik elektrischer Maschinen GmbH
Siemensstr. 7
35394 Giessen
Germany
Phone: +49 641 7969 0
Fax: +49 641 73645
Internet: www.huebner-giessen.com
E-Mail: info@huebner-giessen.com

This manual has been drawn up with the utmost care and attention. Nevertheless, we cannot exclude the possibility of errors in form and content. It is strictly forbidden to reproduce this publication or parts of this publication in any form or by any means without the prior written permission of Johannes Hübner Fabrik elektrischer Maschinen GmbH.

Johannes Hübner Fabrik elektrischer Maschinen GmbH is listed by Underwriters Laboratories.

UL certificates can be requested from us.

An overview of our UL devices can be found at the following link:

<https://iq.ulprospector.com/info>

UL File Number: E351535

Type	UL model No.
FGHJ 2	FGHJ 2 AK-XXXX
FGHJ2 Option S	FGHJ 2 AK-XXXX-S
FGHJ2 KK	FGHJ 2 AKK-XXXX
FGHJ2 mit LWL	FGHJ 2 AL-XXXX

Subject to errors and changes due to technical improvements.
Copyright © Johannes Hübner Fabrik elektrischer Maschinen GmbH
All rights reserved.

Directory

1	General	5
1.1	Information about the operating and assembly instructions	5
1.2	Scope of delivery	5
1.3	Explanation of symbols	5
1.4	Disclaimer	6
1.5	Copyright	6
1.6	Guarantee terms	6
1.7	Customer service	6
2	Safety	6
2.1	Responsibility of the owner	6
2.2	Personnel	6
2.3	Intended use	7
2.4	Improper use	7
2.5	Personal protective equipment	7
2.6	Special dangers	8
2.6.1	Electrical current	8
2.6.2	Rotating shafts / hot surfaces	8
2.6.3	Safeguarding against restart	8
3	Technical Data	9
3.1	Type plates	9
3.2	Electrical and mechanical data	10
3.3	Signal outputs	11
4	Overview additional options	11
4.1	Option S (overspeed switch)	11
4.2	Option LWL (signal transmission using fiber optics)	11
4.3	Option AKK (double pulse output)	11
4.4	Type code	12
5	Transport, packaging and storage	13
5.1	Safety instructions for transport	13
5.2	Incoming goods inspection	13
5.3	Packaging / disposal	13
5.4	Storage of packages (devices)	13
6	Installation and commissioning	14
6.1	Safety instructions	14
6.2	Technical information	14
6.3	Required tools	14
6.4	Mounting preparations	15
6.5	Mounting hollow shaft type	15
6.6	Using the adjustable torque bracket (V2A)	16
6.7	Shortenable torque bracket (V2A optional)	18

6.8	Electrical connection and start up.....	18
6.8.1	Preparing cables	18
6.8.2	Electrical connection.....	18
7	Dismantling	19
7.1	Safety instruction	19
7.2	Dismantling the encoder	19
8	Faults	20
8.1	Faults table	20
9	Inspections.....	21
9.1	Safety instructions.....	21
9.2	Maintenance information	21
9.3	Inspection schedule	21
10	Disposal.....	21
10.1	Disposal procedure	21
11	Replacement parts.....	21
12	Dimension drawings.....	22
13	Connection diagrams	34
13.1	Terminal box	34
13.2	Connection cable	35
13.3	Flange connector ITT-Cannon	35

1 General

1.1 Information about the operating and assembly instructions

These operating and assembly instructions provide important instructions for working with the device. They must be carefully read prior to starting all tasks, and the instructions contained herein must be followed.

In addition, applicable local regulations for the prevention of industrial accidents and general safety regulations must be complied with.

1.2 Scope of delivery

Incremental Hollow Shaft Encoder FGJ 2, operating and assembly instructions, cheese head screw M6x30-ISO 4762, circular spring device with a cylindrical shaft, special tool for mounting/dismantling.

1.3 Explanation of symbols

Warnings are indicated by symbols in these operating and assembly instructions. The warnings are introduced by signal words that express the scope of the hazard.

The warnings must be strictly heeded; you must act prudently to prevent accidents, personal injury, and property damage.



WARNING!

Indicates a possibly dangerous situation that can result in death or serious injury if it is not avoided.



CAUTION!

Indicates a possibly dangerous situation that can result in minor injury if it is not avoided.



CAUTION!

Indicates a possibly dangerous situation that can result in material damage if it is not avoided.



NOTES!

Indicates useful tips and recommendations as well as information for efficient and trouble-free operation.



NOTES!

Do not use a hammer or similar tool when installing the device due to the risk of damage occurring to the bearings or coupling!



DANGER!

Life-threatening danger due to electric shock!

Indicates a life-threatening situation due to electric shock. If the safety instructions are not complied with there is danger of serious injury or death. The work that must be executed should only be performed by a qualified electrician.

1.4 Disclaimer

All information and instructions in these (operating and assembly instructions) have been provided under due consideration of applicable guidelines, as well as our many years of experience.

The manufacturer assumes no liability for damages due to:

- Failure to follow the instructions in the operating and assembly instructions
- Non-intended use
- Deployment of untrained personnel
- Opening of the device or conversions of the device

In all other aspects the obligations agreed in the delivery contract as well as the delivery conditions of the manufacturer apply.

1.5 Copyright



NOTES!

Content information, text, drawings, graphics, and other representations are protected by copyright and are subject to commercial property rights.

It is strictly forbidden to make copies of any kind or by any means for any purpose other than in conjunction with using the device without the prior written agreement of the manufacturer. Any copyright infringements will be prosecuted.

1.6 Guarantee terms

The guarantee terms are provided in the manufacturer's terms and conditions.

1.7 Customer service

For technical information personnel is available that can be contacted by telephone, fax or email. See manufacturer's address on page 2.

2 Safety



DANGER!

This section provides an overview of all the important safety aspects that ensure protection of personnel, as well as safe and trouble-free device operation.

If these safety instructions are not complied with significant hazard can occur.

2.1 Responsibility of the owner

The device is used in commercial applications. Consequently the owner of the device is subject to the legal occupational safety obligations and subject to the safety, accident prevention and environmental protection regulations that are applicable for the device's area of implementation.

2.2 Personnel

Installation and commissioning as well as disassembly routines must be carried out by skilled technical staff only.

2.3 Intended use

The device has been designed and constructed exclusively for the intended use described here.

Series FGJ 2 Incremental Hollow Shaft Encoders are used for measurement of rotations, for instance of electrical and mechanical drives and shafts.

Claims of any type due to damage arising from non-intended use are excluded; the owner bears sole responsibility for non-intended use.

For UL and CSA:

For the use in NFPA 79 applications only.

Option S

The FGJ 2 with option S has in addition to the incremental output a switching output.

The incremental hollow shaft encoder FGJ 2 with option S has been designed and constructed exclusively for the intended use described here.

Series FGJ 2 with option S Incremental Encoders are used for speed monitoring, for instance electrical and mechanical drives, hosting gear, and conveying machines.

The FGJ 2 with option S is a device which generates a switching signal for a superior control system. This is realized with opening of a switch contact.

Claims of any type due to damage arising from non-intended use are excluded. The owner bears sole responsibility for none- intended use.

2.4 Improper use

The device may not be used in explosion-threatened areas.

On the device no other mechanical load may be exercised except his dead weight and the oscillations without fail appearing during the company and pushes.

Examples of inadmissible mechanical charges (incomplete listing):

- Connection of transport- or lifting means in the device, e.g., load hook for raising of an engine.
- Connection of packaging parts in the device, e.g., instep belts, tarpaulin, etc.
- Use of the device as a step, e.g., for going up of a person on an engine.

2.5 Personal protective equipment

For tasks such as assembly, disassembly or commissioning the use of personal protective equipment such as safety footwear and protective work clothing is required.

The regulations specified by the owner and that are locally specified apply.

2.6 Special dangers

Residual risks that have been determined based on a risk assessment are cited below.

2.6.1 Electrical current



DANGER!

Life-threatening danger due to electrical shock!

There is an imminent life-threatening hazard if live parts are touched. Damage to insulation or to specific components can pose a life-threatening hazard.

Therefore:

Immediately switch off the device and have it repaired if there is damage to the insulation of the power supply.

De-energize the electrical equipment and ensure that all components are connected for all tasks on the electrical equipment.

Keep moisture away from live parts. Moisture can cause short circuits.

2.6.2 Rotating shafts / hot surfaces



WARNING!

Danger of injury due to rotating shafts and hot surfaces!

Touching rotating shafts can cause serious injuries.

Therefore:

Do not reach into moving parts/shafts or handle moving parts/shafts during operation. Close to protect from injury all access openings in flanges with the corresponding plug screw, and provided you exposed rotating components with protective covers.

Do not open covers during operation. Prior to opening the covers ensure that all parts have come to a standstill.

The encoder can become hot during prolonged use.

In case of contact risk of burns is existing.

2.6.3 Safeguarding against restart



DANGER!

Life-threatening danger if restarted without authorization!

When correcting faults there is danger of the power supply being switched on without authorization.

This poses a life-threatening hazard for persons in the danger zone.

Therefore:

Prior to starting work, switch off the system and safeguard it from being switched on again.

3 Technical Data

3.1 Type plates

Below are some nameplates for different device models shown.

Without option S or fibre optic cable



With option S or LWL

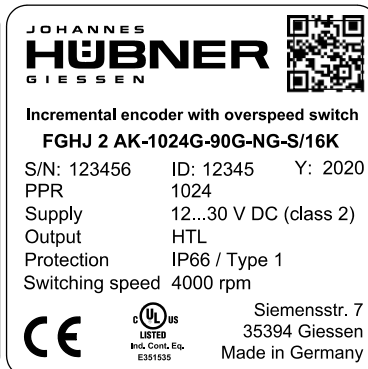

The nameplate and UKCA label are located on the side of the housing and contain the following information:

Englisch	Deutsch
Manufacturer, address	Hersteller, Anschrift
Type: Incremental Encoder, Year of manufacture	Typ: Inkrementaler Drehgeber, Baujahr
CE mark	CE-Kennzeichnung
Serial number (S/N)	Seriennummer (S/N)
Pulse rate	Impulszahl
Degree of protection	Schutzart
Supply voltage	Versorgungsspannung
Outputs	Ausgänge
Max. speed	Max. Drehzahl
Switching speed	Schalterdrehzahl
Certification references	Zertifizierungshinweise
QR-Code	QR-Code

3.2 Electrical and mechanical data

Pulse Rates	600, 1024, 2048, others on request			
Connection data				
Supply voltage	12 V...30 VDC Ripple max. 10 % For UL and CSA Class 2 supplied			
No load-current	approx. 50 mA at 24 V			
Connection	spring-cage terminal strip, Type Phoenix ZFKDS 1,5-W-5,08 (0,25 mm ² - 1,5 mm ²)			
Connection (Option fiber optic)	St-fiber optic plug			
Outputs	Current limited, short-circuit proof push-pull line driver			
Pulse height (HTL)	approx. as supply voltage output saturation voltage < 0.4 V at I _L 30 mA			
Output current	150 mA peak			
Internal resistance	75 Ω at 24 V			
Slew rate	200 V / μs with C _L 100 pF			
Duty cycle	1 : 1 ± 5 %			
Square wave displacement 0°, 90°	90° ± 5 %			
Max. frequency	200 kHz			
Start-up time	< 50 ms			
Encoder temperature range standard	-25°C ... + 85°C			
Special Encoder temperature range	-40°C ... + 85°C			
Special Encoder temperature range	-40°C ... + 100°C (UL/CSA: max. +85°C)			
Degree of protection acc. DIN EN 60529	Sealing	Mech. permissible speed	Rotor moment of inertia	Breakaway torque
IP66 (UL/CSA Type 1)	with Labyrinth seal (aluminum housing)	≤ 6000 rpm	approx. 315 gcm ²	approx. 3,5 ...4 Ncm
Vibration resistance aluminum housing	DIN EN 60068-2-6 / IEC 68-2-6 (10 ... 2000 Hz)		20 g (=200 m/s ²)	
Shock resistance aluminum housing	DIN EN 60068-2-27 / IEC 68-2-27 (6 ms)		200 g (=2000 m/s ²)	
Weight aluminum housing	approx. 2 kg			

3.3 Signal outputs

Signal outputs			
Basic channel 0° (A) and pulse channel 90° (B) Reference pulse (N) mechanically defined; one square-wave pulse per revolution Each with inverted signals	0°		Incr. Output 0°
	$\overline{0^\circ}$		Incr. Output 0° Inverse
	90°		Incr. Output 90°
	$\overline{90^\circ}$		Incr. Output 90° Inverse
	N		Reference
	\overline{N}		Reference Inverse

4 Overview additional options

4.1 Option S (overspeed switch)

The incremental hollow shaft encoder FGJ 2 with option S has an insulated switching output. The switching function is realized with a semiconductor, the switching speed is set in our factory (switching hysteresis 10%).

If the set switching speed is exceeded, the switch opens.

It is recommended to save the switch circuit against an overcurrent with a fuse (0,5A).

Specification	Value
Deviation from switch:	Accuracy of measurement: 2% Switching time $T_{sw} < 3ms$
Switch data	0...30V DC/max 500mA Max. voltage drop at closed switch: 0,7V

4.2 Option LWL (signal transmission using fiber optics)

The signals 0°, 90° and marker pulse from the incremental encoder will be encoded and transmitted via fiber optics cable. Fiber optic cable types 50/125 µm or 62,5/125 µm are available.

4.3 Option AKK (double pulse output)

Incremental encoder with optic scanning in redundant design. This provides the following combinations of the output signals.

FG(HJ) 2	Output 1 (Basic unit)	Output 2 (double pulse output)
Redundant (number of pulses)	1024	1024
Redundant (number of pulses)	2048	2048
Combined (number of pulses)	1024	2048

4.4 Type code

	FGH	J	2	AK	1024	G	90G	NG	S	16K/ 17C
Incremental hollow shaft encoder										
with isolated bearings										
Series										
Connections										
AK: Terminal box										
AKK: Double pulse output										
AL: Terminal box with connector for ST-compatible fiber optic plug										
I: 10-pole flange connector ITT Cannon (not combinable with Option S) (Pin compatible with POG 10 DN 1024 I)										
Pulses per rotation										
600, 1024, 2048, others on request										
Basic version										
Basic channel 0° (A)										
Pulse channel 90° (B)										
each with inverted signals (not for LWL see chapter. 4.2)										
NG: Reference pulse with inverted signal										
S: Option S										
Hollow shaft bore										
16K cylindrical shaft with clamping										
17C cone shaft										
0,75 R with clamping ring										
12K cylindrical shaft with clamping										

5 Transport, packaging and storage

5.1 Safety instructions for transport



CAUTION!

Material damage caused by improper transport!

Observe the symbols and information on the packaging:

- Do not throw - risk of breakage
- Keep dry
- Do not expose to heat above 40 °C or direct sunlight.

5.2 Incoming goods inspection

Check delivery immediately upon receipt for completeness and possible transport damage.

Inform the forwarder directly on receipt of the goods about existing transport damages (prepare pictures for evidence).

5.3 Packaging / disposal

The packaging is not taken back and must be disposed of in accordance with the respective statutory regulations and local guidelines.

5.4 Storage of packages (devices)



Keep dry

Keep packages dry and free from dust; protect from moisture.

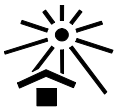

Protect against heat

Protect packages from heat above 40 °C and direct sunlight.

If you intend to store the device for a longer period of time (> 6 months) we recommend you use protective packaging (with desiccant).



NOTES!

Turn the shaft of the device every 6 month to prevent the bearing grease solidifying!

6 Installation and commissioning

6.1 Safety instructions



WARNING!

Observe the safety instructions contained in **Chapter 2** when dismantling the device!

Personnel

Installation and commissioning must be carried out by skilled technical staff only.

6.2 Technical information



NOTES!

Do not use a hammer or similar tool when installing the device due to the risk of damage occurring to the bearings or coupling!

Ambient temperature

The max. permissible ambient temperature depends on the speed and degree of protection of the device, the signal frequency, the length of the signal cable and the place of installation (please refer to Chapter 3.2).

Degree of protection

To fulfill degree of protection requirements the diameter of the connection cable must correspond to that of the cable gland (please refer to Chapter 12 Dimension drawings)!

Deep groove ball bearings

FGJ 2 incremental hollow shaft encoders are fitted with maintenance-free, greased "for-life" deep groove bearings. Bearings must be changed by the manufacturer only. Opening the encoder renders the guarantee null and void.

Screw retention

We recommend using Loctite® 243 threadlocker (medium strength) on all fastening screws to prevent loosening.

6.3 Required tools

- Spanners: 12 mm, 10 mm, 22 mm (e.g. DIN 894)
- Allen keys: 2 mm, 3 mm, 5 mm, 6 mm
- Flat-blade screwdrivers:
- Assembly grease
- Loctite® 243 (medium strength threadlocker)

6.4 Mounting preparations

1. Ensure all accessories are available (please refer to Chapter 12 Dimension drawings).



NOTES!

Fastening screws and earth cable are not included in the range of supply.

2. Preparing the place of attachment: Clean the (motor) shaft, centering, bolting surfaces and fastening threads; check for damage. Repair any damage!

6.5 Mounting hollow shaft type

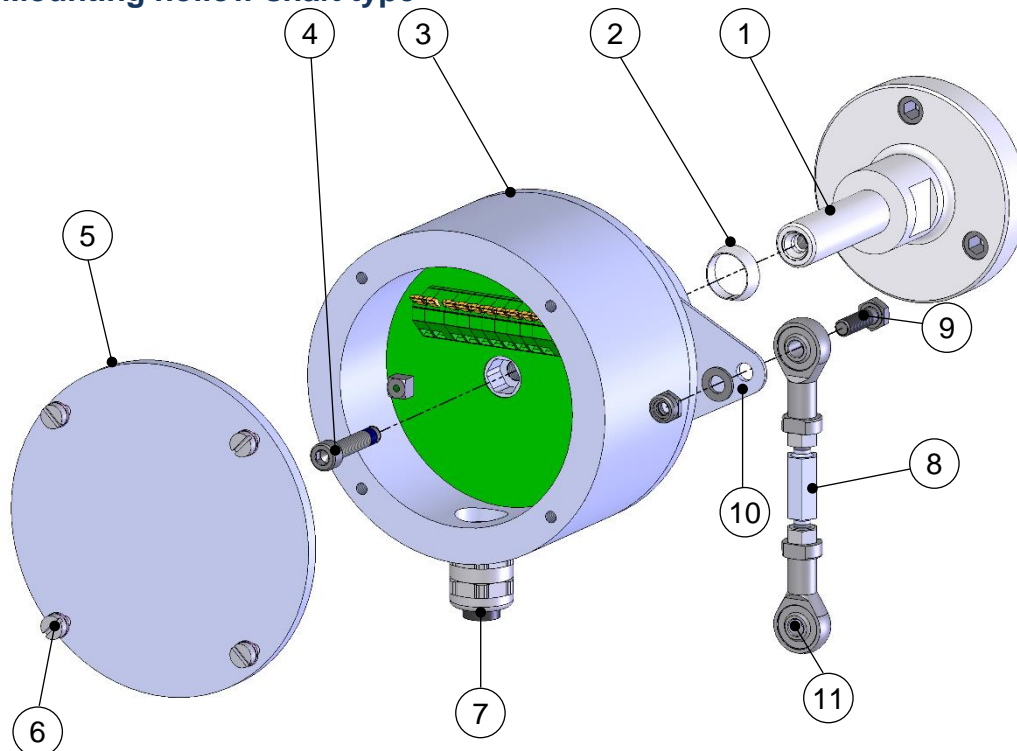

Fig. 1

1. Mount adapter shaft (1) and align using dial gauge.

NOTES!

The maximum radial run-out of the adapter shaft/motor shaft should not exceed 0,2 mm. We recommend a radial deviation of 0,03 mm.

If necessary, use the ball thrust adjustment screw to align the adapter shaft. Secure ball thrust screws with Loctite® 243. Remove unused ball thrust screws or secure with Loctite® 243. Max. tightening torque for M12 approx. 25 Nm, for M16 approx. 35 Nm.

Use parallel keys to DIN 6885.

Please also observe the supplement data sheet Mounting accuracy for hollow shaft encoders.

You should also observe the Installation instructions supplied with the adapter shaft when installing!



2. Lightly grease the adapter shaft, open the device.
3. Slide the circular spring device (2) onto the adapter shaft until it stops.
4. Mount the hollow shaft device (3) to the adapter shaft.

The hollow shaft encoder must slide smoothly on to the adapter shaft. In no delay with increased force, otherwise the bearing may be damaged. Where appropriate adapter shaft with emery cloth rework. The hollow shaft encoder does not strike hard against the shaft shoulder.

5. Secure the hollow shaft device with the aid of the hexagon socket head cap screw (4). (Fig.1) maximum tightening 6 Nm.



NOTES!

The cap screws have a coating with micro-encapsulated adhesive for securing screws. If screws are used without micro-adhesive coating the screws are with Loctite® 243 to be secured.

6. Close the hollow shaft device with cover (5) and 4 screws (6).
7. Fastening the torque bracket:

Bolt the link rod (8) with screw (9), washer and nut with torque bracket (10).

The ideal angle of torque bracket (10) to the link rod (8) is 90°.

Secure the link heads (11) of the link rod to a fixed point (for example on the motor housing).



NOTES!

Once fitted the link rod must rotate easily around the link rod heads! Failure to observe this point may result in damage to the bearings!



NOTES!

The link heads are maintenance free. However, ensure they remain free from soiling and paint!

6.6 Using the adjustable torque bracket (V2A)

The torque bracket is supplied completely screwed together. To adjust the length of the torque bracket, release the interlocked nuts. Turn the rigging screw to the left or to the right to adjust the torque bracket to the required length. Then tighten the hex nuts to lock the adjusted length.

Number	ID Number	Minimum length (mm)	Maximum length (mm)
1	21402	141	180
2	21403	180	250
3	21404	250	350

	<p>Number 1 min. length in mm</p>
	<p>Number 1 max. length in mm</p>
	<p>Number 2 min. length in mm</p>
	<p>Number 2 max. length in mm</p>
	<p>Number 3 min. length in mm</p>
	<p>Number 3 max. length in mm</p>

6.7 Shortenable torque bracket (V2A optional)

The torque arms in the table below can be shortened by the customer.
See dimension drawing HM 13 M 106952a Chapter 12.

Type	ID Number	Min. length (mm)	Max. length (mm)
D	21975	71	390
E	22057	71	430

6.8 Electrical connection and start up



NOTES!

You must observe applicable EMC guidelines when routing cables!



NOTES for UL and CSA!

Do only use copper cables!

6.8.1 Preparing cables

1. Strip cable insulation. The cable for the signal and supply line is shielded, the cable for the option S will not be shielded.
2. Crimp wire-end ferrules.

6.8.2 Electrical connection

1. Open the terminal box cover (5, Fig.1).



CAUTION!

Do not allow moisture to enter the terminal box when the cover is open!

2. Remove the cap of the cable gland (7, Fig.1).
3. Feed the cable into the terminal box trough the cable gland.



NOTES!

The signal cable shielding has to be connected directly to the housing via the EMC cable gland.

To achieve an effective shielding the cable shield must also be connected in the electrical cabinet.

4. Tighten the cable gland using a spanner.



NOTES!

Prior to delivery cable glands and blanking plugs are tightened finger tight only. To ensure that the terminal box is reliably sealed tighten all cable glands and blanking plugs before starting up for the first time.

5. Use a spanner to tighten the cable gland until the cable is securely clamped and properly sealed.



NOTES!

Prevent lateral pulling forces acting on the cable so as not to impair the degree of protection of the cable gland.

6. Connect the supply voltage, the signal cable and possibly option S (please refer to the connection diagrams, Chapter 13).



CAUTION!

Do not apply supply voltage to the signal outputs, as this will destroy the device!

7. Close the terminal box cover.



NOTES!

Before closing the terminal box cover check and if necessary clean both seal surfaces and the gasket.



CAUTION!

Ensure when closing the terminal box cover that no cable becomes jammed.

For encoders with option S only:

1. Remove the blind plug from inside of the housing
2. Remove the cable gland
3. Close the opening with the blind plug

7 Dismantling

7.1 Safety instruction

Personnel

Dismantling must be carried out by skilled technical staff only.



WARNING!

Observe the safety instructions contained in **Chapter 2** when dismantling the device!



NOTES!

Do not use a hammer or similar tool when dismantling the device due to the risk of damage occurring to the bearings or coupling!

7.2 Dismantling the encoder

Disconnect all electrical cable prior to beginning any work.

To dismantling the encoder follow the instructions given in Chapter 6.5 in the reverse order.

For dismounting first a threaded pin M6x10 ISO 7436 has to be screwed into the adapter shaft. With a screw M8, the encoder must be pressed. Optionally, the adapter shaft must be secured against turning

8 Faults

8.1 Faults table

Faults	Possible cause	Remedy
Switch does not close (only by option S)	No supply voltage <u>Control</u> : LED in the terminal box does not shine	Check connection cable and supply voltage
	<u>Error LED does not shine</u> : Rotation speed above the switching speed	Adjust the suitable rotation speed
	<u>Error LED is shining</u> : Evaluation of rotation speed is faulty.	Disconnect power supply and switch on again
Moisture in the terminal box	Soiled terminal box gasket or seal surfaces	Clean terminal box gasket and seal surfaces
	Damaged terminal box gasket	Replace terminal box gasket
	Cable gland/blanking plug not tightened	Tighten cable gland/blanking plug
	Unsuitable cable for cable gland	Use suitable cable and cable glands
No output signals	Supply voltage not connected	Connect supply voltage
	Connection cable reversed	Wire correctly
Output signals subject to interference	Unsuitable cable	Use data cable with conductors arranged as twisted pairs and common shield
	Cable shield not connected	Connect cable shield at both ends
	Cable routing not EMC compliant	Observe applicable EMC guidelines when routing cables
Signal interruptions	Signal end stage overloaded	Check pin assignment; observe connection diagram
		Do not assign unused outputs
	Outputs short-circuited	Do not connect outputs with supply voltage or GND

Contact Hubner-Service (page 2) if none of the remedies listed above provides a solution)!

9 Inspections

9.1 Safety instructions



WARNING!

Skilled technical staff only are permitted to inspect the device and its installation. Observe the safety instructions contained in **Chapter 2** when inspecting or working on the device!

9.2 Maintenance information

The device is maintenance-free. However, to guarantee optimum fault-free operations we recommend that you carry out the following inspections.

9.3 Inspection schedule

Interval	Inspections
Yearly	Inspect the coupling for damage and ensure it is free of play
	Ensure the fastening screws are properly tightened
	Ensure cable connections and connection terminals are securely seated
Following approx 16 000 – 20 000 hours of operation / higher levels of continuous load	Check deep groove ball bearings are running smoothly and listen for running noises
For FG(H)2 with option S, no extra inspection is required.	

10 Disposal

10.1 Disposal procedure

The manufacturer is not obliged to take back the device.

The device is classed as electronic equipment and subject to the WEEE Directive; observe local, country-specific laws when disposing of the device.

For information on environmentally sound disposal please contact your local authority or a specialist disposal company.

11 Replacement parts

The in the following listed spare parts can be covered when required about the service address on the page 2.

Spare part	Remark
EMC cable gland	M20 x 1,5, cable Ø 9...13 mm
Terminal box cover	Incl. o-ring and screws
Angle plug - 10-pole complete	

12 Dimension drawings

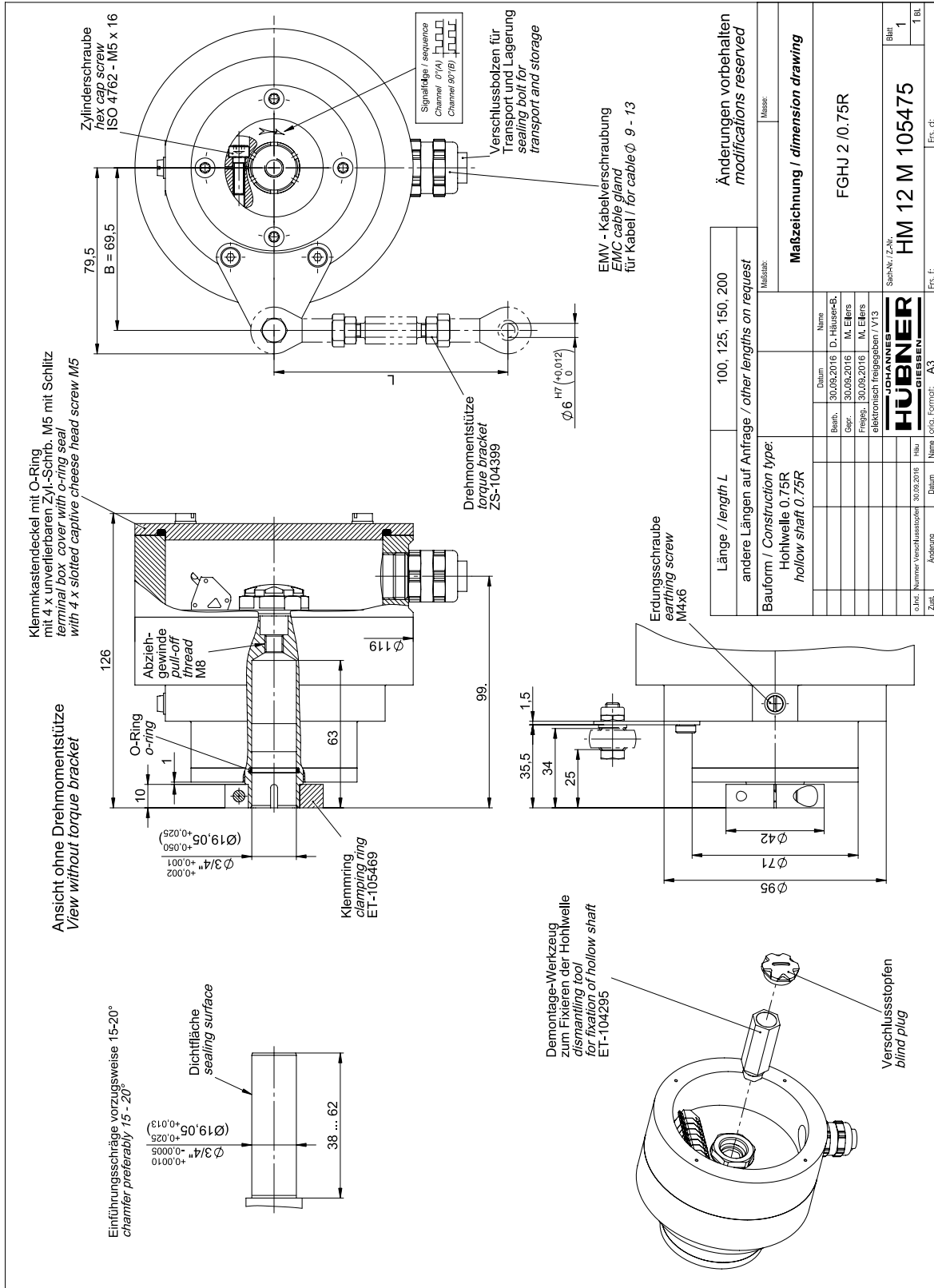

Incremental Hollow Shaft Encoder FGJH 2

Signalfolge / sequence
Channel 0(A) 1(B) 2(C) 3(D) 4(E) 5(F) 6(G) 7(H) 8(I) 9(J) 10(K) 11(L) 12(M) 13(N) 14(O) 15(P) 16(Q) 17(R) 18(S) 19(T) 20(U) 21(V) 22(W) 23(X) 24(Y) 25(Z) 26(+) 27(-) 28(0) 29(1) 30(2) 31(3) 32(4) 33(5) 34(6) 35(7) 36(8) 37(9) 38(10) 39(11) 40(12) 41(13) 42(14) 43(15) 44(16) 45(17) 46(18) 47(19) 48(20) 49(21) 50(22) 51(23) 52(24) 53(25) 54(26) 55(27) 56(28) 57(29) 58(30) 59(31) 60(32) 61(33) 62(34) 63(35) 64(36) 65(37) 66(38) 67(39) 68(40) 69(41) 70(42) 71(43) 72(44) 73(45) 74(46) 75(47) 76(48) 77(49) 78(50) 79(51) 80(52) 81(53) 82(54) 83(55) 84(56) 85(57) 86(58) 87(59) 88(60) 89(61) 90(62) 91(63) 92(64) 93(65) 94(66) 95(67) 96(68) 97(69) 98(70) 99(71) 100(72) 101(73) 102(74) 103(75) 104(76) 105(77) 106(78) 107(79) 108(80) 109(81) 110(82) 111(83) 112(84) 113(85) 114(86) 115(87) 116(88) 117(89) 118(90) 119(91) 120(92) 121(93) 122(94) 123(95) 124(96) 125(97) 126(98) 127(99) 128(100) 129(101) 130(102) 131(103) 132(104) 133(105) 134(106) 135(107) 136(108) 137(109) 138(110) 139(111) 140(112) 141(113) 142(114) 143(115) 144(116) 145(117) 146(118) 147(119) 148(120) 149(121) 150(122) 151(123) 152(124) 153(125) 154(126) 155(127) 156(128) 157(129) 158(130) 159(131) 160(132) 161(133) 162(134) 163(135) 164(136) 165(137) 166(138) 167(139) 168(140) 169(141) 170(142) 171(143) 172(144) 173(145) 174(146) 175(147) 176(148) 177(149) 178(150) 179(151) 180(152) 181(153) 182(154) 183(155) 184(156) 185(157) 186(158) 187(159) 188(160) 189(161) 190(162) 191(163) 192(164) 193(165) 194(166) 195(167) 196(168) 197(169) 198(170) 199(171) 200(172) 201(173) 202(174) 203(175) 204(176) 205(177) 206(178) 207(179) 208(180) 209(181) 210(182) 211(183) 212(184) 213(185) 214(186) 215(187) 216(188) 217(189) 218(190) 219(191) 220(192) 221(193) 222(194) 223(195) 224(196) 225(197) 226(198) 227(199) 228(200) 229(201) 230(202) 231(203) 232(204) 233(205) 234(206) 235(207) 236(208) 237(209) 238(210) 239(211) 240(212) 241(213) 242(214) 243(215) 244(216) 245(217) 246(218) 247(219) 248(220) 249(221) 250(222) 251(223) 252(224) 253(225) 254(226) 255(227) 256(228) 257(229) 258(230) 259(231) 260(232) 261(233) 262(234) 263(235) 264(236) 265(237) 266(238) 267(239) 268(240) 269(241) 270(242) 271(243) 272(244) 273(245) 274(246) 275(247) 276(248) 277(249) 278(250) 279(251) 280(252) 281(253) 282(254) 283(255) 284(256) 285(257) 286(258) 287(259) 288(260) 289(261) 290(262) 291(263) 292(264) 293(265) 294(266) 295(267) 296(268) 297(269) 298(270) 299(271) 300(272) 301(273) 302(274) 303(275) 304(276) 305(277) 306(278) 307(279) 308(280) 309(281) 310(282) 311(283) 312(284) 313(285) 314(286) 315(287) 316(288) 317(289) 318(290) 319(291) 320(292) 321(293) 322(294) 323(295) 324(296) 325(297) 326(298) 327(299) 328(300) 329(301) 330(302) 331(303) 332(304) 333(305) 334(306) 335(307) 336(308) 337(309) 338(310) 339(311) 340(312) 341(313) 342(314) 343(315) 344(316) 345(317) 346(318) 347(319) 348(320) 349(321) 350(322) 351(323) 352(324) 353(325) 354(326) 355(327) 356(328) 357(329) 358(330) 359(331) 360(332) 361(333) 362(334) 363(335) 364(336) 365(337) 366(338) 367(339) 368(340) 369(341) 370(342) 371(343) 372(344) 373(345) 374(346) 375(347) 376(348) 377(349) 378(350) 379(351) 380(352) 381(353) 382(354) 383(355) 384(356) 385(357) 386(358) 387(359) 388(360) 389(361) 390(362) 391(363) 392(364) 393(365) 394(366) 395(367) 396(368) 397(369) 398(370) 399(371) 400(372) 401(373) 402(374) 403(375) 404(376) 405(377) 406(378) 407(379) 408(380) 409(381) 410(382) 411(383) 412(384) 413(385) 414(386) 415(387) 416(388) 417(389) 418(390) 419(391) 420(392) 421(393) 422(394) 423(395) 424(396) 425(397) 426(398) 427(399) 428(400) 429(401) 430(402) 431(403) 432(404) 433(405) 434(406) 435(407) 436(408) 437(409) 438(410) 439(411) 440(412) 441(413) 442(414) 443(415) 444(416) 445(417) 446(418) 447(419) 448(420) 449(421) 450(422) 451(423) 452(424) 453(425) 454(426) 455(427) 456(428) 457(429) 458(430) 459(431) 460(432) 461(433) 462(434) 463(435) 464(436) 465(437) 466(438) 467(439) 468(440) 469(441) 470(442) 471(443) 472(444) 473(445) 474(446) 475(447) 476(448) 477(449) 478(450) 479(451) 480(452) 481(453) 482(454) 483(455) 484(456) 485(457) 486(458) 487(459) 488(460) 489(461) 490(462) 491(463) 492(464) 493(465) 494(466) 495(467) 496(468) 497(469) 498(470) 499(471) 500(472) 501(473) 502(474) 503(475) 504(476) 505(477) 506(478) 507(479) 508(480) 509(481) 510(482) 511(483) 512(484) 513(485) 514(486) 515(487) 516(488) 517(489) 518(490) 519(491) 520(492) 521(493) 522(494) 523(495) 524(496) 525(497) 526(498) 527(499) 528(500) 529(501) 530(502) 531(503) 532(504) 533(505) 534(506) 535(507) 536(508) 537(509) 538(510) 539(511) 540(512) 541(513) 542(514) 543(515) 544(516) 545(517) 546(518) 547(519) 548(520) 549(521) 550(522) 551(523) 552(524) 553(525) 554(526) 555(527) 556(528) 557(529) 558(530) 559(531) 560(532) 561(533) 562(534) 563(535) 564(536) 565(537) 566(538) 567(539) 568(540) 569(541) 570(542) 571(543) 572(544) 573(545) 574(546) 575(547) 576(548) 577(549) 578(550) 579(551) 580(552) 581(553) 582(554) 583(555) 584(556) 585(557) 586(558) 587(559) 588(560) 589(561) 590(562) 591(563) 592(564) 593(565) 594(566) 595(567) 596(568) 597(569) 598(570) 599(571) 600(572) 601(573) 602(574) 603(575) 604(576) 605(577) 606(578) 607(579) 608(580) 609(581) 610(582) 611(583) 612(584) 613(585) 614(586) 615(587) 616(588) 617(589) 618(590) 619(591) 620(592) 621(593) 622(594) 623(595) 624(596) 625(597) 626(598) 627(599) 628(600) 629(601) 630(602) 631(603) 632(604) 633(605) 634(606) 635(607) 636(608) 637(609) 638(610) 639(611) 640(612) 641(613) 642(614) 643(615) 644(616) 645(617) 646(618) 647(619) 648(620) 649(621) 650(622) 651(623) 652(624) 653(625) 654(626) 655(627) 656(628) 657(629) 658(630) 659(631) 660(632) 661(633) 662(634) 663(635) 664(636) 665(637) 666(638) 667(639) 668(640) 669(641) 670(642) 671(643) 672(644) 673(645) 674(646) 675(647) 676(648) 677(649) 678(650) 679(651) 680(652) 681(653) 682(654) 683(655) 684(656) 685(657) 686(658) 687(659) 688(660) 689(661) 690(662) 691(663) 692(664) 693(665) 694(666) 695(667) 696(668) 697(669) 698(670) 699(671) 700(672) 701(673) 702(674) 703(675) 704(676) 705(677) 706(678) 707(679) 708(680) 709(681) 710(682) 711(683) 712(684) 713(685) 714(686) 715(687) 716(688) 717(689) 718(690) 719(691) 720(692) 721(693) 722(694) 723(695) 724(696) 725(697) 726(698) 727(699) 728(700) 729(701) 730(702) 731(703) 732(704) 733(705) 734(706) 735(707) 736(708) 737(709) 738(710) 739(711) 740(712) 741(713) 742(714) 743(715) 744(716) 745(717) 746(718) 747(719) 748(720) 749(721) 750(722) 751(723) 752(724) 753(725) 754(726) 755(727) 756(728) 757(729) 758(730) 759(731) 760(732) 761(733) 762(734) 763(735) 764(736) 765(737) 766(738) 767(739) 768(740) 769(741) 770(742) 771(743) 772(744) 773(745) 774(746) 775(747) 776(748) 777(749) 778(750) 779(751) 780(752) 781(753) 782(754) 783(755) 784(756) 785(757) 786(758) 787(759) 788(760) 789(761) 790(762) 791(763) 792(764) 793(765) 794(766) 795(767) 796(768) 797(769) 798(770) 799(771) 800(772) 801(773) 802(774) 803(775) 804(776) 805(777) 806(778) 807(779) 808(780) 809(781) 810(782) 811(783) 812(784) 813(785) 814(786) 815(787) 816(788) 817(789) 818(790) 819(791) 820(792) 821(793) 822(794) 823(795) 824(796) 825(797) 826(798) 827(799) 828(800) 829(801) 830(802) 831(803) 832(804) 833(805) 834(806) 835(807) 836(808) 837(809) 838(810) 839(811) 840(812) 841(813) 842(814) 843(815) 844(816) 845(817) 846(818) 847(819) 848(820) 849(821) 850(822) 851(823) 852(824) 853(825) 854(826) 855(827) 856(828) 857(829) 858(830) 859(831) 860(832) 861(833) 862(834) 863(835) 864(836) 865(837) 866(838) 867(839) 868(840) 869(841) 870(842) 871(843) 872(844) 873(845) 874(846) 875(847) 876(848) 877(849) 878(850) 879(851) 880(852) 881(853) 882(854) 883(855) 884(856) 885(857) 886(858) 887(859) 888(860) 889(861) 890(862) 891(863) 892(864) 893(865) 894(866) 895(867) 896(868) 897(869) 898(870) 899(871) 900(872) 901(873) 902(874) 903(875) 904(876) 905(877) 906(878) 907(879) 908(880) 909(881) 910(882) 911(883) 912(884) 913(885) 914(886) 915(887) 916(888) 917(889) 918(890) 919(891) 920(892) 921(893) 922(894) 923(895) 924(896) 925(897) 926(898) 927(899) 928(900) 929(901) 930(902) 931(903) 932(904) 933(905) 934(906) 935(907) 936(908) 937(909) 938(910) 939(911) 940(912) 941(913) 942(914) 943(915) 944(916) 945(917) 946(918) 947(919) 948(920) 949(921) 950(922) 951(923) 952(924) 953(925) 954(926) 955(927) 956(928) 957(929) 958(930) 959(931) 960(932) 961(933) 962(934) 963(935) 964(936) 965(937) 966(938) 967(939) 968(940) 969(941) 970(942) 971(943) 972(944) 973(945) 974(946) 975(947) 976(948) 977(949) 978(950) 979(951) 980(952) 981(953) 982(954) 983(955) 984(956) 985(957) 986(958) 987(959) 988(960) 989(961) 990(962) 991(963) 992(964) 993(965) 994(966) 995(967) 996(968) 997(969) 998(970) 999(971) 1000(972)

Ansicht ohne Drehmomentstütze
View without torque bracket

Klemmkastendeckel mit O-Ring
mit 4 x unverlierbaren Zyl.-Schrb. M5 mit Schlitz
terminal box cover with O-ring seal
with 4 x slotted captive cheese head screw M5

Drehmomentstütze
torque bracket
ZS-104399

Verschlussbolzen für
Transport und Lagerung
sealing bolt for
transport and storage

EMV - Kabelverschraubung
EMC cable gland
für Kabel / for cable ϕ 9 - 13

Abziehgewinde
pull-off
thread
M8

O-Ring
o-ring

Erdungsschraube
earthing screw
M4x6

Spannelement-Innenring geschlitzt
Locking element inner ring slotted
KT-107886

Beispiel einer Welle / example of shaft

Dichtfläche
sealing surface

Einführungsschräge vorzugsweise 15° - 20°
chamfer, preferably 15° - 20°

Zyl.-Schrb.
ISO 4762 siehe Tabelle
cheese-head screw
see table

Montage-/ Demontage-Werkzeug
zum Fixieren der Hohlwelle
Mounting-/ dismantling tool
for fixation of hollow shaft
ET-104295

Verschlussstopfen
blind plug

ET-108500 Scheibe / washer

Wellenlänge shaft length	Schraube M5x ... mit Scheibe screw M5x ... with washer	Schraube M6x ... ohne Scheibe screw M6x ... without washer	Anziehmoment tightening torque
53 ... 49	20	20	M5 5.7Nm M6 9.8Nm
48 ... 47	25	25	
46 ... 44	30	30	

Maßzeichnung / dimension drawing

Änderungen vorbehalten
modifications reserved

Maßstab:

Blatt: 1

Blatt: 1 Bl.

Spezifikation: FGJH 2 / 12K

Hersteller: HUBNER
GESIMMEL

Produktionsdatum: 30.09.2016

Gepr.: M. Ellers

Freigegeben: 30.09.2016

elektronisch freigegeben / V24

Änderung: Datum Name / org. format: AS

Erst.: Ers.:

Ansicht ohne Drehmomentstütze
View without torque bracket

Klemmkastendeckel mit O-Ring
mit 4 x unverlierbaren Zyl.-Schr. M5 mit Schlitz
terminal box cover with O-ring seal
with 4 x slotted captive cheese head screw M5

Drehmomentstütze
torque bracket
ZS-104399

Verschlussbolzen für
Transport und Lagerung
sealing bolt for
transport and storage

EMV - Kabelverschraubung
EMC cable gland
für Kabel / for cable ϕ 9 - 13

Erdungsschraube
earthing screw
M4x6

Spannelement-Innenring geschlitzt
Locking element inner ring slotted
KT-103715

Einführungsschräge vorzugsweise 15-20°
chamfer, preferably 15 - 20°

Dichtfläche
sealing surface

Zentriergewinde / centering thread
DIN332 Bl. 2 - DS M6

Zyl.-Schr.
ISO 4762-M6x30-A2
cheese-head screw
mikroklebstoffbeschichtet
micro-adhesive coated
zul. Anzugsmoment: **6 Nm**
max tightening torque: **6 Nm**
ET-104295

Montage-/ Demontage-Werkzeug
zum Fixieren der Hohlwelle
Mounting-/ dismantling tool
for fixation of hollow shaft

Stützscheibe / washer
DIN 988-SS 6x12

Verschlussstopfen
blind plug

HT (+0,018)
 $\phi 16$

HT (+0,012)
 $\phi 6$

min. $\phi 20$

M6

16

52

2

1

O-Ring
O-ring

Abziehwende
pull-off
thread

M8

118

91

54

52

27,5

26

17

1,5

71

95

79,5

B = 69,5

Signalfolge / sequence
Channel 0(A) 1111111111
Channel 0(B) 1111111111

Maßstab:

Länge / length L 100, 125, 150, 200
andere Längen auf Anfrage / other lengths on request

Bauform / Construction type:
Hohlwelle $\phi 16$ K
hollow shaft $\phi 16$ K

Änderungen vorbehalten
modifications reserved

Maßzeichnung / dimension drawing

FGJH 2 /16K

Name		Datum	
Bezh.	30.09.2016	D. Häusel-B.	
Gepr.	30.09.2016	M. Eilers	
Freigepr.	30.09.2016	M. Eilers	
Hwu.	30.09.2016	elektronisch freigegeben / V05	
Div. Änderungen	31.07.2012	Mb	
Div. Änderungen	27.08.2012	Echb	
Div. Änderungen	18.11.2011	DBB	

Blatt 1
1 Bl.

HM 11 M 104034b

Erst.:

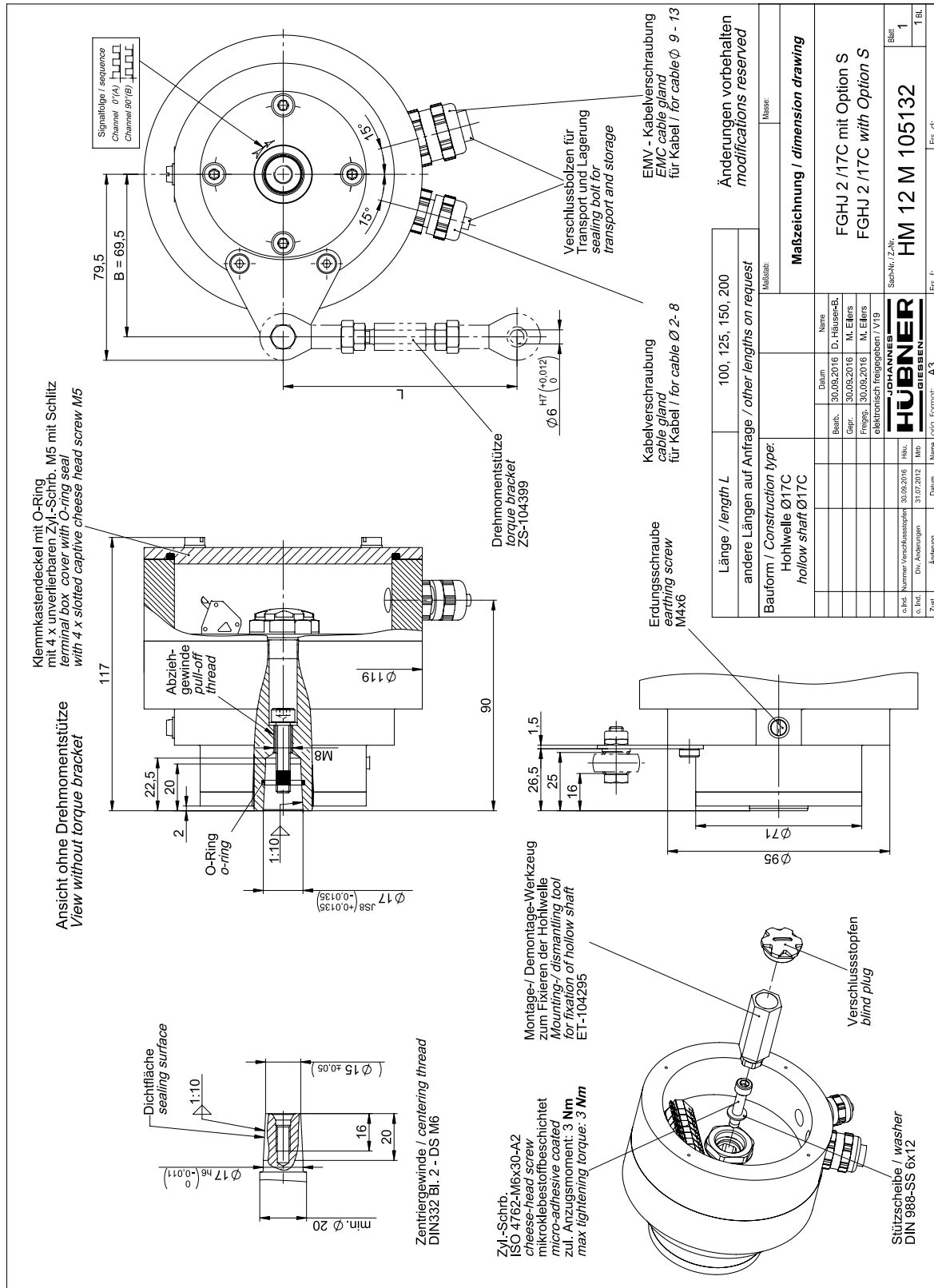

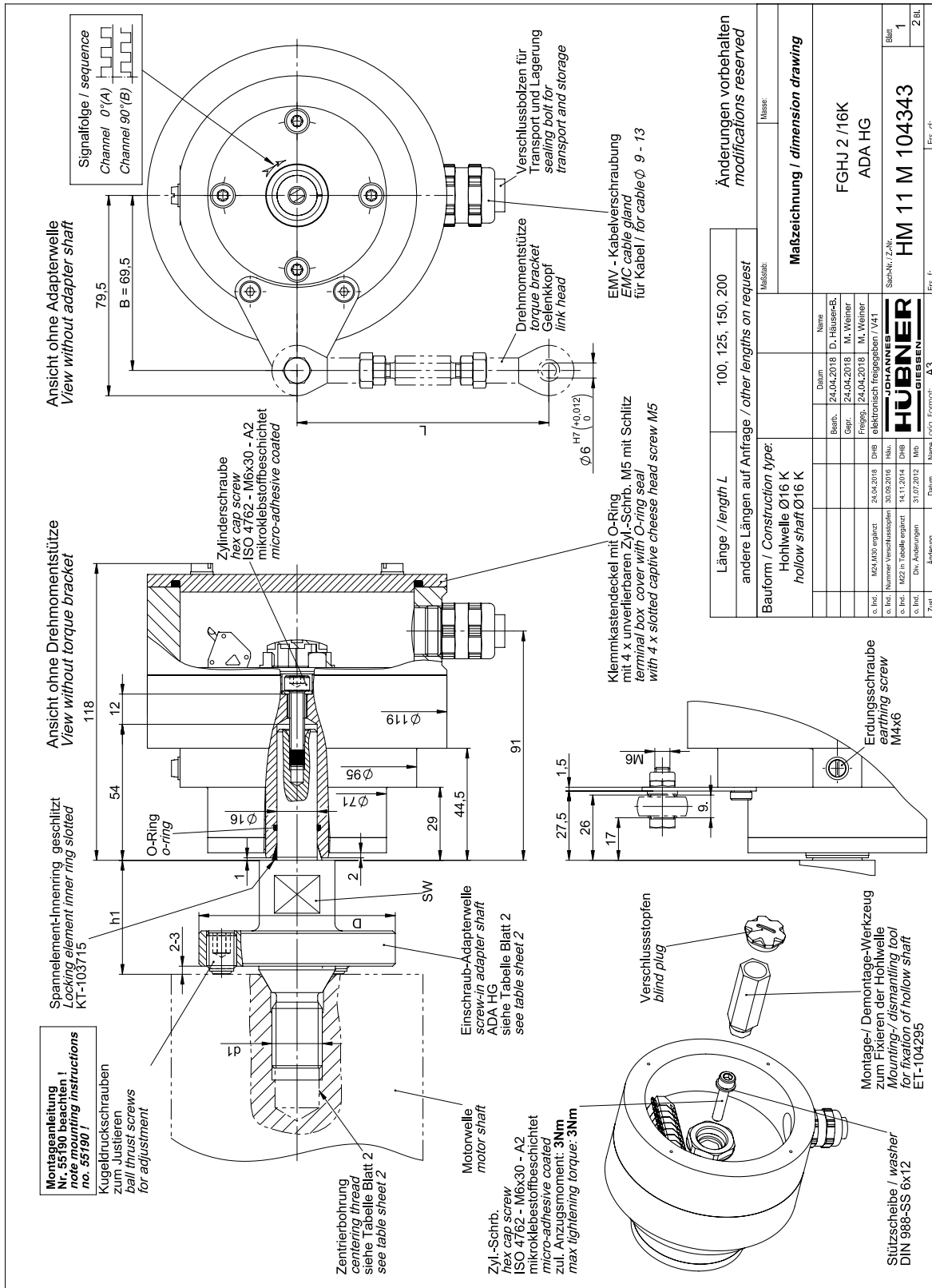

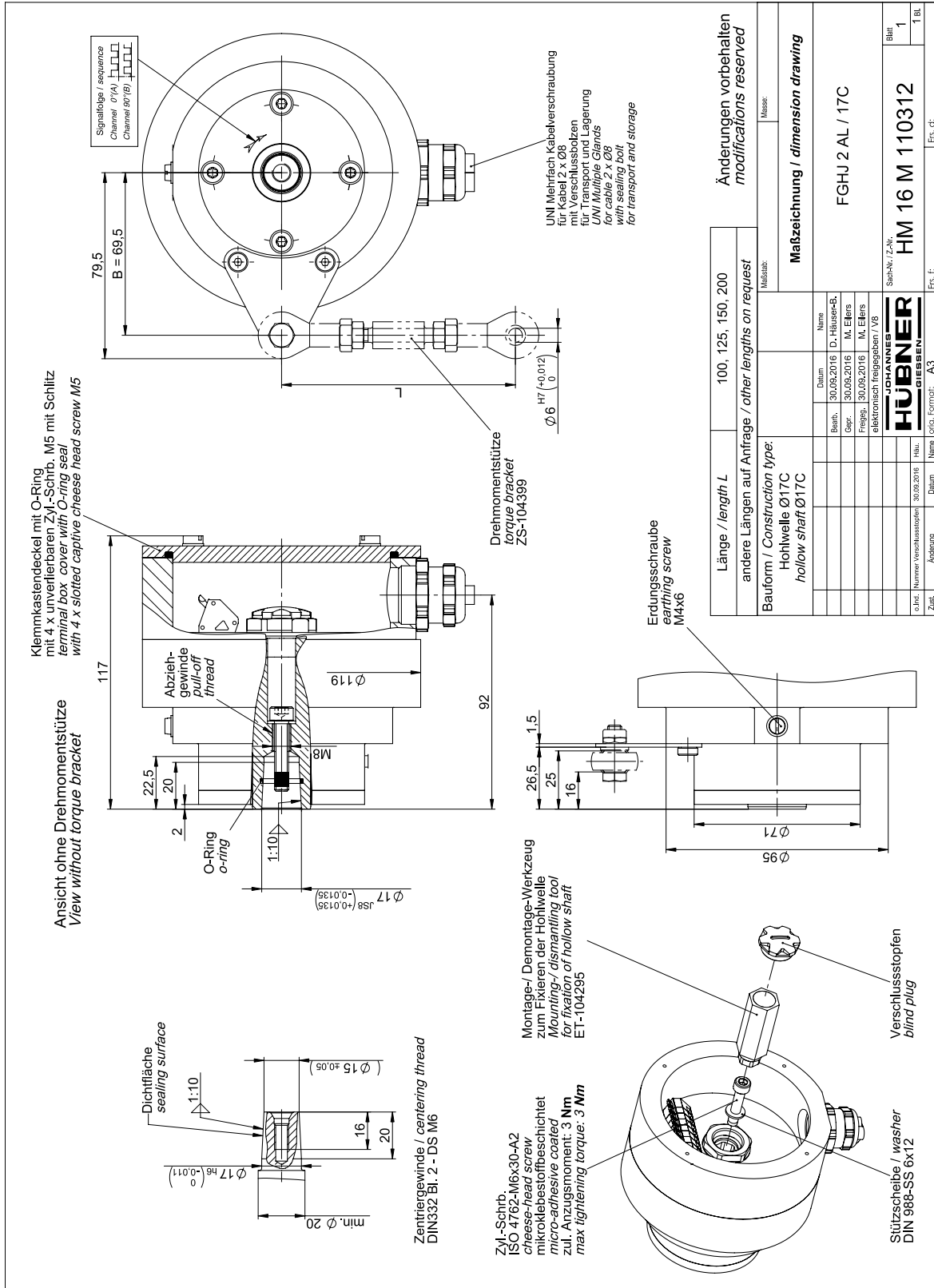

Signalfolge / sequence
Channel 0*(A)
Channel 90*(B)

$B = 69.5$

79.5

$ca. 125$

Flanschdose
10-polig
mit Bajonett
Anschluss
flange socket
10-pole
with bayonet
coupling

Bitte separat
bestellen!
Please order
separately!

ITT-Cannonsteckverbinder 90° -
10-polig mit Bajonett Anschluss
ITT-Cannon connector 90° -
10-pole with bayonet coupling

$\phi 6$

$H7 (+0,012)$

EMV - Kabelverschraubung
EMC cable gland
für Kabel / for cable ϕ 6.5 - 9.5

Drehmomentsstütze
torque bracket
ZS-104399

Klemmkastendeckel mit O-Ring
mit 4 x unverlierbaren Zyl.-Schrub. M5 mit Schlitz
terminal box cover with O-ring seal
with 4 x slotted captive cheese head screw M5

123

Abziehgewinde
pull-off
thread
M8

$\phi 119$

$ca. 93.3$

O-Ring
o-ring

2

0.8

52

54

$\phi 12$
 $H7 (+0,018)$

Spannelement-Innenring geschlitzt
Locking element inner ring slotted
KT-107686

Spannelement-Innenring geschlitzt
Locking element inner ring slotted
KT-107686

Beispiel einer Welle / example of shaft

$\phi 12$
 $h6 (-0,008)$

$44 \dots 53$

10

$M5 / M6$

Dichtfläche
sealing surface

Einführungsschräge vorzugsweise 15° - 20°
chamfer preferably 15° - 20°

Zyl.-Schrub.
ISO 4762 siehe Tabelle
cheese-head screw
see table

mit Loctite® 243 gesichert
with Loctite® 243 secured

Montage-/ Demontage-Werkzeug
zum Fixieren der Hohlwelle
Mounting-/ dismantling tool
for fixation of hollow shaft
ET-104295

Verschlussstopfen
mit O-Ring
blind plug with o-ring

ET-108500 Scheibe / washer

Oberteil des ITT-Cannonsteckverbinders
verstellbar, 24 Raststellungen je 15°
upper section of ITT-Cannon connector
adjustable, 24 catch positions each 15°

Erdungsschraube
earthing screw
M4x6

Länge / length L 100, 125, 150, 200
andere Längen auf Anfrage / other lengths on request

Bauform / Construction type:
Hohlwelle $\phi 12$ K
hollow shaft $\phi 12$ K

Maßstab

Maßzeichnung / dimension drawing

FGJH 2 AI/12K
mit ITT-Cannon-Steckverbinder 90° und
EMV-Kabelverschraubung
with ITT Cannon-Connector 90° and
EMC cable gland

Sachnr./Z.Nr.:
HM 17 M 111341

Blatt:
1
1 Rl.

Zust. Änderung Datum Name (orig. format): A3

Erst. dt.

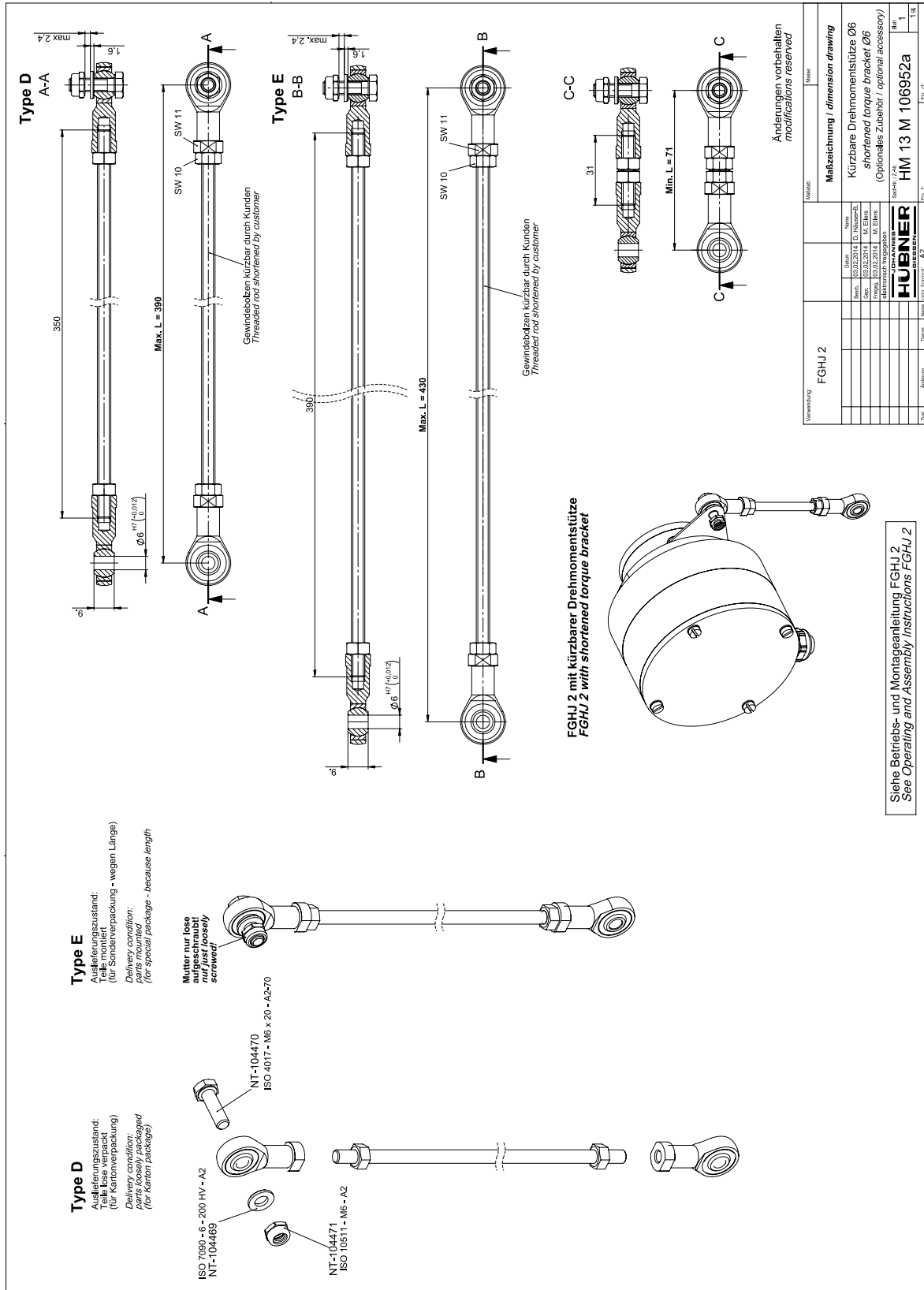

13 Connection diagrams

13.1 Terminal box



NOTES!

The connection diagrams are displayed in each terminal box cover!

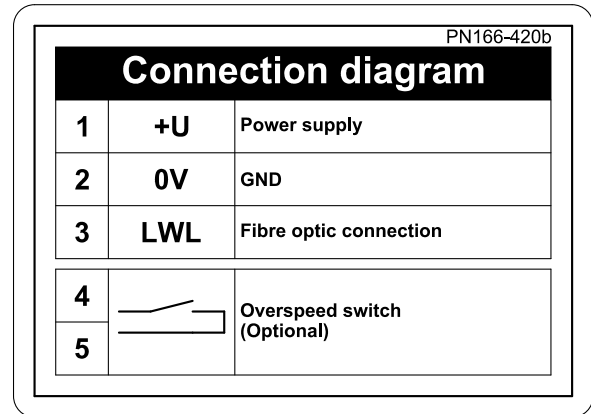
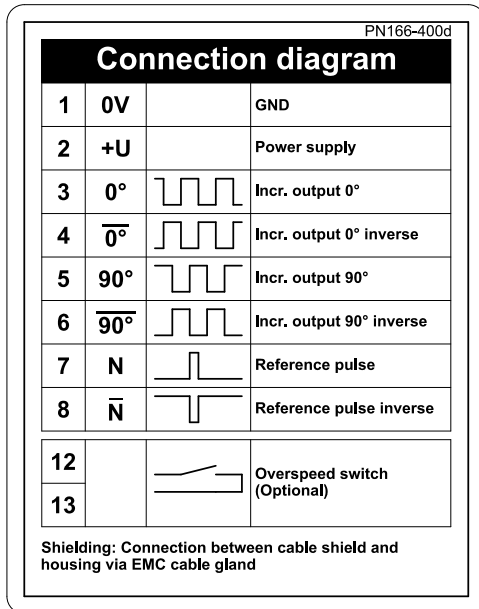

Connection technology AK

Connection technology AL

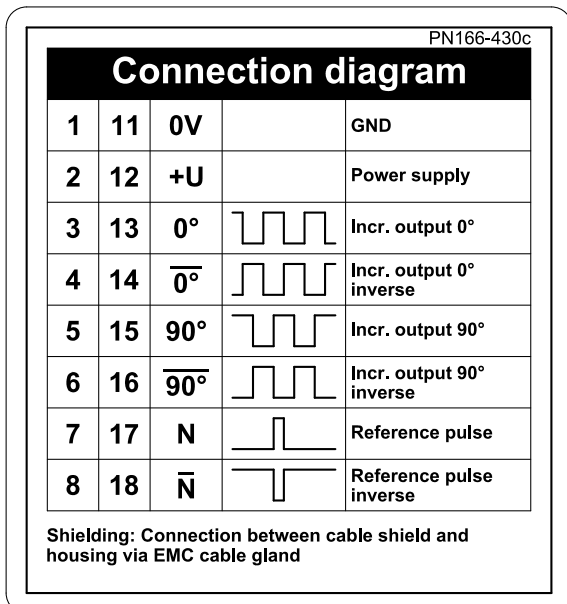

Connection technology AKK

13.2 Connection cable

NOTES!
The connection diagrams are attached to each cable!

PN166-450

Connection diagram

WH	0,5	∞	0V	GND
BN	0,5		+U	Power supply
BN	0,25	∞	0°	Incr. output 0°
GN	0,25		$\overline{0^\circ}$	Incr. output 0° inverse
GY	0,25	∞	90°	Incr. output 90°
PK	0,25		$\overline{90^\circ}$	Incr. output 90° inverse
RD	0,25	∞	N	Reference pulse
BK	0,25		\overline{N}	Reference pulse inverse
BU	0,25	∞	-	-
VT	0,25		-	-

Connection cable:
LAPPGROUP ÖLFLEX® SERVO FD 798 CP
4x2x0.25+2x0.5 twin-stranded, shielded

PN166-460

Connection diagram

WH	0,5		Overspeed switch
BN	0,5		

Connection cable:
IGUS chainflex® CF9.UL.05.02 control cable TPR
2x0,5

Connection cable

Connection cable (option S)

13.3 Flange connector ITT-Cannon

PN166-470

Connection diagram

Flange connector ITT Cannon

J	0V	GND
C	+U	Power supply
A	0°	
E	$\overline{0^\circ}$	
B	90°	
F	$\overline{90^\circ}$	
D	N	
G	\overline{N}	
H	-	Not connected
I	-	Not connected

10-pole-flange connector ITT Cannon