



## Operating and assembly instructions

### USL(H) 42

### Safety certified basic units

### U-ONE<sup>®</sup>-SAFETY-LWL

## Universal encoder system – Generation II

Read the operating and assembly manual before carrying out assembly, starting installation, or completing other work.

Store the manual for future use.

**Manufacturer / Publisher**

Johannes Hübner

Fabrik elektrischer Maschinen GmbH

Siemensstr. 7

35394 Giessen / Germany

Phone: +49 641 7969 0

Fax: +49 641 73645

Internet: [www.huebner-giessen.com](http://www.huebner-giessen.com)

E-mail: [info@huebner-giessen.com](mailto:info@huebner-giessen.com)

Further current information on this product series can be found online in our Service Point.

Simply scan the QR Code and open the link in your browser.



These instructions and the enclosed declaration of conformity can also be accessed via our Service Point. For this purpose, the QR code on the type plate of the corresponding device must be scanned.

### **Trademarks**

Brand names and product names are trademarks or registered trademarks of their respective owner. Protected trademarks bearing a <sup>TM</sup> or ® symbol are not always depicted as such in the manual. However, the statutory rights of the respective owners remain unaffected.

### **Copyright**

It is strictly forbidden to reproduce this publication or parts of this publication in any form or by any means without the prior written permission of Johannes Hübner Fabrik elektrischer Maschinen GmbH. Content information, text, drawings, graphics, and other representations are protected by copyright and are subject to commercial property rights. Duplications of any kind that are not combined with use of the machine are prohibited without manufacturer's written consent. Actions to the contrary make damage compensation mandatory.

**Copyright© Johannes Hübner Fabrik elektrischer Maschinen GmbH**

### **Change reservation**

The manual has been drawn up with the utmost care and attention. Nevertheless, we cannot exclude the possibility of errors in form and content.

**All rights, subject to errors and changes due to technical improvements reserved.**

## Table of contents

<b>1</b>	<b>General information .....</b>	<b>6</b>
1.1	Information on the operating and assembly manual.....	6
1.2	Scope of delivery .....	6
1.3	Explanation of symbols.....	6
1.4	Warranty and liability .....	7
1.5	Organisational measures.....	7
1.6	Copyright protection .....	7
1.7	Warranty provisions.....	7
1.8	Customer service.....	8
<b>2</b>	<b>Basic safety information .....</b>	<b>8</b>
2.1	Responsibility of the operator .....	8
2.2	Selecting and qualifying personnel; basic obligations .....	8
2.3	Proper use.....	9
2.4	Improper use .....	9
2.5	Safety information.....	10
<b>3</b>	<b>Assembly .....</b>	<b>11</b>
3.1	Safety information.....	11
3.2	Technical information.....	12
3.2.1	Assembly for design B5 (flange) .....	13
3.2.2	Assembly for design B35 (flange and base).....	14
3.2.3	Installation of hollow shaft version .....	16
3.3	Disassembly.....	18
3.3.1	Disassembly of the USL 42.....	18
3.3.2	Exchanging the USL 42 .....	18
3.4	Installation .....	19
3.4.1	Safety instructions .....	19
3.4.2	Basic rules .....	19
3.4.3	Connection .....	19
<b>4</b>	<b>Technical data .....</b>	<b>22</b>
4.1	Type plate.....	22
4.2	Type designation .....	22
4.3	Mechanical data .....	23
4.3.1	Solid shaft encoder .....	23
4.3.2	Hollow shaft encoder .....	24
4.3.3	Bearing service life .....	24
4.3.4	Speed derating .....	25
4.4	Electrical data.....	25
4.5	Operating modes and displays .....	26
<b>5</b>	<b>Structure and function .....</b>	<b>26</b>
<b>6</b>	<b>Functional safety .....</b>	<b>27</b>
6.1	Safety parameters .....	27
6.2	Information on functional safety .....	27

<b>7 Inspections .....</b>	<b>28</b>
7.1 Safety information.....	28
7.2 Maintenance information .....	28
7.3 Inspection plan .....	28
<b>8 Transportation, packaging and storage.....</b>	<b>29</b>
8.1 Transportation safety information .....	29
8.2 Incoming goods controlling .....	29
8.3 Packaging (disposal) .....	29
8.4 Storing packages (devices).....	29
8.5 Returning equipment (repair/goodwill/warranty).....	29
8.6 Disposal .....	30
<b>9 Accessories .....</b>	<b>31</b>
9.1 Safety-integrated solid shaft installation.....	31
9.2 Safety-integrated hollow shaft installation .....	32
9.3 Cable protection systems .....	32
9.4 Couplings for safety-integrated solid shaft installation .....	33
<b>10 Documents.....</b>	<b>34</b>
10.1 Dimensional drawings.....	34
10.2 Connection diagram .....	38

## 1 General information

### 1.1 Information on the operating and assembly manual

This operating and assembly manual provides important information on how to use the U-ONE®-SAFETY-LWL safety certified basic device. It must be read carefully before beginning any work and must be observed. The U-ONE®-SAFETY-LWL basic device is called the USL 42 in the following documentation.

Furthermore, local accident prevention regulations and general safety regulations applicable in the area where the USL 42 is used must be observed.

### 1.2 Scope of delivery

The scope of delivery for the USL 42 includes the attachment screws, washers, the declaration of conformity and the operating and assembly manual.

### 1.3 Explanation of symbols

Warning notices in this operating and assembly manual are designated using symbols. Information is preceded by signal words which express the extent of the danger involved. Always comply with these notices, and use caution to avoid accidents, personal injury and property damage.



**WARNING!**

Indicates a potentially hazardous situation that could lead to death or severe injury if it is not avoided.



**CAUTION!**

Indicates a potentially hazardous situation that could lead to minor or slight injuries if it is not avoided.



**CAUTION!**

Indicates a potentially hazardous situation that could lead to property damage if it is not avoided.



**NOTE!**

Emphasises useful tips and recommendations, and provides information useful for efficient, smooth operation.



**NOTE!**

Using a hammer or similar tools during installation is not permitted, due to the danger of damage to the ball bearings and couplings.

## 1.4 Warranty and liability

Only the “General Terms and Conditions” of the company Johannes Hübner Fabrik elektrischer Maschinen GmbH apply. These will be available to the operator at the latest when the order is confirmed or when the contract is concluded. All warranty and liability claims for personal injury and property damage are excluded, and the operator's operating permit will be null and void if one or more of the following apply:

- Failure to observe the operating and assembly manual.
- Improper use of the USL 42
- Improper assembly, installation, commissioning and programming of the USL 42.
- Improper work completed on the USL 42
- Operating the USL 42 despite technical defects.
- Independently carrying out mechanical or electrical modifications to the USL 42.
- Independently carrying out repairs.
- Catastrophes due to external interference or force majeure.
- Use of non-qualified personnel.
- Opening the USL 42 (except for the terminal box) or completing conversions.

## 1.5 Organisational measures

- The operating and assembly manual must always be stored easily within reach in the area where the USL 42 is used.
- In addition to the operating and assembly manual, general statutory and other binding regulations on accident prevention and environmental protection must be observed. Operators must be trained on these regulations.
- Applicable national, local, and system-specific provisions and requirements must be observed. Operators must be trained on these provisions.
- The operator is obligated to inform personnel of special operating considerations and requirements.
- Personnel commissioned to complete work on the USL 42 must read and familiarise themselves with the operating and assembly manual before beginning work, in particular section 2.
- The type plate and any prohibitions or notice signs adhered to the USL 42 must always be legible.
- Do not carry out mechanical or electrical modifications to the USL 42, except for those expressly described in this operating and assembly manual.

Repairs may only be carried out by the manufacturer, or by an agency or individual authorised by the manufacturer.

## 1.6 Copyright protection

	<p><b>NOTE!</b></p> <p>Content information, texts, drawings, images, and other illustrations are copyright protected and subject to industrial property rights. Copying of any kind not associated with use of the USL 42 is prohibited without a written declaration from the manufacturer. Violations will result in claims for damages.</p>
---	--

## 1.7 Warranty provisions

Warranty provisions are outlined in the manufacturer's General Delivery Conditions.

## 1.8 Customer service

Contact persons are available by phone, fax, or e-mail for technical questions. See the manufacturer's address on page 2.

## 2 Basic safety information



### **CAUTION!**

This section provides an overview of all significant safety aspects necessary to protect personnel and ensure safe, fault-free operation of the USL 42. Failure to observe this information may result in significant danger.

### 2.1 Responsibility of the operator

The USL 42 is used in commercial areas. The operator of the USL 42, therefore, is subject to statutory occupational safety requirements and the safety, accident prevention and environmental regulations applicable to the areas in which the USL 42 is used.

### 2.2 Selecting and qualifying personnel; basic obligations

- All work on the USL 42 may be carried out only by qualified personnel. Qualified personnel are personnel with the training, experience, and instruction, as well as expertise on relevant standards, specifications, accident prevention regulations and operating circumstances necessary to carry out the required work, and who have been authorised to do so by the persons responsible for the safety of the system. They are able to identify and avoid potential hazards.
- In addition, please see standards VDE 0105-100 and IEC 60364 for the definition of "qualified personnel" (reference, e.g. Beuth Verlag GmbH, VDE-Verlag GmbH)
- Responsibilities for assembly, installation, commissioning and operation must be clearly defined. Personnel who are receiving instruction or training must be supervised.



## 2.3 Proper use

The USL 42 can only be used in conjunction with the UO-SCU function module and other function modules,

- to securely determine angular movements (with UO-SPB-1 or UO-SPN-1)
- for secure, position-dependent switching of potential-free relay contacts (with UO-SRC-R)
- for secure, speed-dependent switching of potential-free relay contacts (with UO-SGS-R)
- for secure, error-dependent switching of potential-free relay contacts (with UO-SRC-R or UO-SGS-R)

The system manufacturer must review whether the properties of the USL 42 fulfil the safety requirements in its specific application. The system manufacturer is responsible for use of the USL 42 and for deciding whether to use the USL 42. The USL 42 is designed for unsupervised, continuous operation.

### Proper use also includes:

- observing all information in this operating and assembly manual,
- observing type plates and any prohibition or information signs attached to the USL 42,
- observing the operating manual of the machine or system manufacturer,
- operating the USL 42 within the limits stipulated in the technical data,
- secure (positive-locking) attachment of the USL 42 to the drive axis,
- not engaging in improper use.

## 2.4 Improper use

	<p><b>WARNING!</b></p> <p>Danger of death, physical injury and property damage due to improper use of the USL 42!</p> <p>In particular, the following uses are prohibited:</p> <ul style="list-style-type: none"> <li>• Use in environments with an explosive atmosphere,</li> <li>• Use in environments with radioactive radiation,</li> <li>• Use for medical purposes,</li> <li>• Attaching transportation or lifting equipment to the USL 42 or load hooks to lift a motor,</li> <li>• Attaching packaging equipment to the USL 42, such as belts, tarps, etc.,</li> <li>• Using the USL 42 as a step, for instance to allow personnel to climb on a motor,</li> <li>• The USL 42 is not intended for use in residential areas and cannot provide adequate protection for radio reception in such areas. The device is classified in Group 1 and Class A according to EN 55011 and is intended for use in an industrial environment only.</li> </ul>
---	--

## 2.5 Safety information

	<p><b>WARNING! NOTE!</b></p> <p>Destruction, damage or impact to the function of the USL 42.</p> <ul style="list-style-type: none"> <li>• Only complete wiring work and only connect or disconnect electrical connections when the USL 42 is powered down.</li> <li>• Heating/cooling must be used at the installation location to prevent the device from falling below or exceeding the permitted ambient temperature limits.</li> <li>• Review any potential hazards due to interactions with other systems and devices currently installed in the surrounding area, or which are to be installed. The user is responsible for taking relevant measures.</li> <li>• The power supply must be secured with a fuse appropriate for the diameter of the intake line.</li> <li>• Cables used must be suitable for the temperature range.</li> <li>• A defective USL 42 may not be operated.</li> <li>• Ensure the installation area is protected against aggressive media (acids, etc.).</li> <li>• Shocks (such as impact by a hammer) to the shaft are not permitted during assembly.</li> <li>• Opening the USL 42 is prohibited (except for the terminal box).</li> <li>• The type plate specifies the technical properties of the USL 42. If the type plate is no longer legible, or if the type plate is missing entirely, the USL 42 may not be operated. Please contact Hübner service (see page 2).</li> </ul>
---	--

	<p><b>NOTE!</b></p> <p><b>Disposal:</b></p> <p>If the USL 42 needs to be disposed after its service life, applicable national regulations must be observed.</p>
---	---

### 3 Assembly

#### 3.1 Safety information

	<p><b>WARNING!</b></p> <ul style="list-style-type: none"> <li>• Observe the safety information in section 2 during assembly, disassembly, and other work on the USL 42.</li> <li>• All assembly, disassembly and other work on the USL 42 may be carried out only by qualified personnel.</li> </ul>
---	--

	<p><b>DANGER! NOTE!</b></p> <p><b>Danger of death, severe physical injury and/or property damage due to deactivating safety functions, caused by an unsecured shaft drive.</b></p> <ul style="list-style-type: none"> <li>• The system manufacturer or operator must take structural measures to ensure that the drive of the USL 42 by the shaft and attachment (see section 3.2) function at all times (fault exclusion). Observe the specifications of DIN EN 61800-5-2:2008 “Electrical power drives with adjustable speed” – Safety requirements, table D.16 – Movement and position sensors”.</li> <li>• In general, the requirements and acceptance conditions for the system as a whole must be observed.</li> <li>• We recommend using our specially designed mechanical safety components: play-free, torsion-resistant HKS5 coupling with fault exclusion to install the USL 42 (see sec. 9.4) as well as an intermediate flange with fault exclusion for the solid shaft, or a safe, insulated adapter shaft for hollow shaft devices.</li> </ul> <p><b>Since the installation will differ depending on the application, the following information may not necessarily be complete.</b></p> <ul style="list-style-type: none"> <li>• All screws must be installed with the torque specified in the operating manual. Setting processes must be avoided, due to the danger that the connection may come loose. Screws must be tightened as necessary.</li> <li>• Using the USL 42 at low ambient temperatures will result in increased starting torque values. This must be taken into consideration when installing the shaft drive.</li> <li>• When using a coupling, the manufacturer's notices and installation requirements must be observed.</li> </ul>
--	--

### 3.2 Technical information



**NOTE!**

Using a hammer or similar tools during installation, disassembly and other work on the USL 42 is not permitted, due to the danger of damage to the ball bearings and couplings.

#### **Working temperature**

The working temperature (housing temperature) must be within the permitted range (see sec. 4.3).

#### **Protective class**

The diameter of the connection cable must be appropriate for the cable glands and terminal box, in order to fulfil the protective class. (see section 4.3)

The end cap must be installed in the hollow shaft version.

#### **Ball bearing**

The USL 42 contains maintenance-free ball bearings with lifetime lubrication. The bearings may only be exchanged by the manufacturer.

#### **Screw lock**

All attachment screws must be secured against unintentional loosening. We recommend using Loctite® 243 (medium strength screw locking agent).

#### **required tools**

Hex wrenches:                      Sizes 10, 13, 22

Allen keys:                         5 mm, 6 mm

Flat screwdriver

Mounting grease

Loctite® 243 (medium strength screw locking agent)

#### **Assembly preparation**

1. Check accessories to ensure they are all present.
2. Preparing the installation site: Clean the drive shaft, centring, screw-fitting surfaces and attachment threads and check them for damage. Repair any damage.

#### **Personnel**

Assembly and commissioning may only be carried out by qualified personnel.



**NOTE!**

Observe the safety information in section 2 during assembly and commissioning.

### 3.2.1 Assembly for design B5 (flange)



**NOTE!**

Example assembly (for dimensional drawing, see section 10).

The following assembly description is only an example, and may vary depending on the type of coupling or flange used. The specific instructions of the coupling manufacturer must be observed.

- The coupling must be mounted so it is easy to move. Adjust the drill holes for used couplings if necessary.
- Mount the intermediate flange (4), so that the screw plug (16) points down, if possible.
- For step 9, it may be necessary to turn the drive shaft (1) to the desired position.
- The spacer (12), flange (4) and coupling (3) must fulfil the requirements for safe installation. See also sec. 9.4.

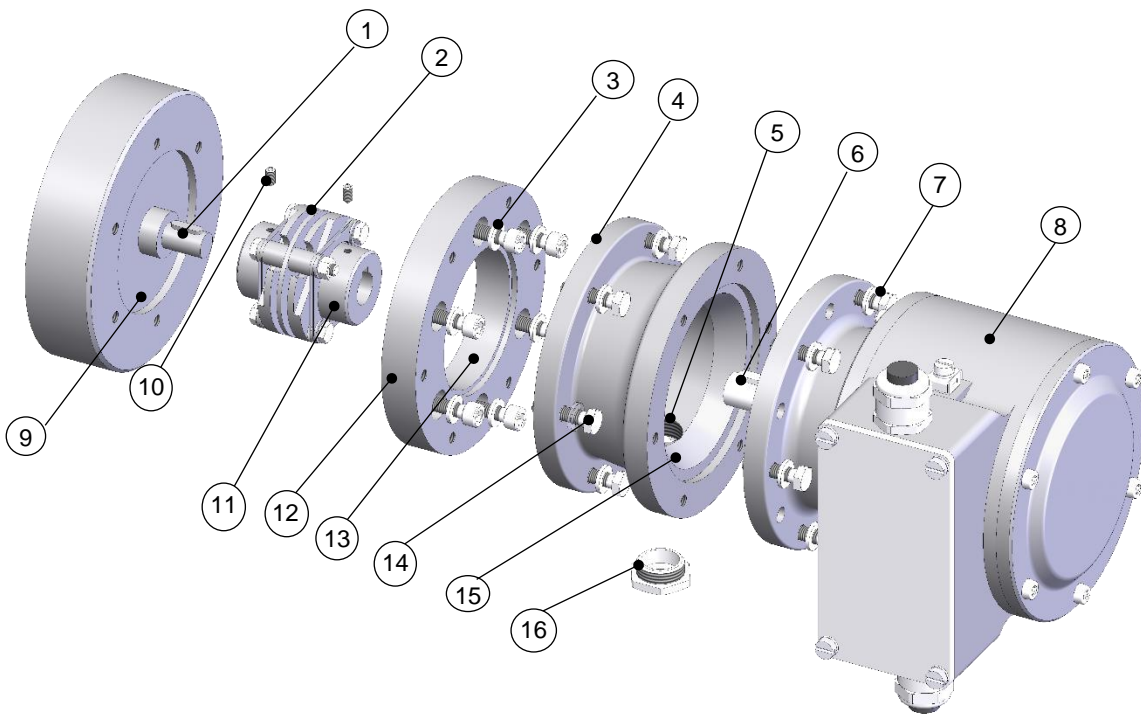

Fig. 3-1: Example design B5

1. Grease the drive shaft (1) lightly.
2. Mount the coupling (2) on the drive shaft (1).
3. Attach the coupling hub to the drive shaft (1) using a grub screw or regular screw (10) (depending on the coupling design).
4. Attach the spacer (12) to the drive side using the attachment screws and washers (3). Lightly grease the centering for this purpose.
5. Attach the intermediate flange (4) to the spacer (12) using the attachment screws (14) and washers (14). Ensure that the intermediate flange and coupling are aligned so that the coupling setscrews remain accessible through the screw plug (16).
6. Insert the USL 42 (8) into the centring (15) and coupling hub (11) at the same time.

7. Fasten the USL 42 with at least 6 screws and washers (7) distributed evenly over the circumference of the flange (4). Tightening torque: 7 Nm
8. Remove the screw plug (16) from the access opening (5) to the coupling.
9. Attach the coupling hub to the shaft using a grub screw or regular screw (10) (depending on the coupling design).
10. Close the access opening on the intermediate flange (4) to the coupling using the screw plug (16).

#### Attachment screws

The following conditions must be complied for proper assembly:

Tensile strength	Screw	Tightening torque
200...279 N/mm <sup>2</sup>	M6x25 - 8.8	7 Nm
≥ 280 N/mm <sup>2</sup>	M6x20 - 8.8	7 Nm

The screw length is based on fastening to a steel or cast iron component. Other materials may require a different screw length.

#### 3.2.2 Assembly for design B35 (flange and base)

	<p><b>NOTE!</b> A USL 42 version B35 can be attached using the flange (B5) or base (B3). Example assembly (for dimensional drawing, see section 10). The following assembly description is only an example, and may vary depending on the type of coupling used. The specific instructions of the coupling manufacturer must be observed. The coupling must be mounted so it is easy to move. Adjust the drill holes for used couplings if necessary. Angular errors and parallel misalignment between the drive shaft and shaft of the USL 42 are considered installation errors, and must be kept as small as possible. <b>Installation errors:</b> - cause radial force to act on the USL 42 shaft. - reduce the service lives of the ball bearings and coupling. - reduce signal quality (harmonics).</p>
---	---

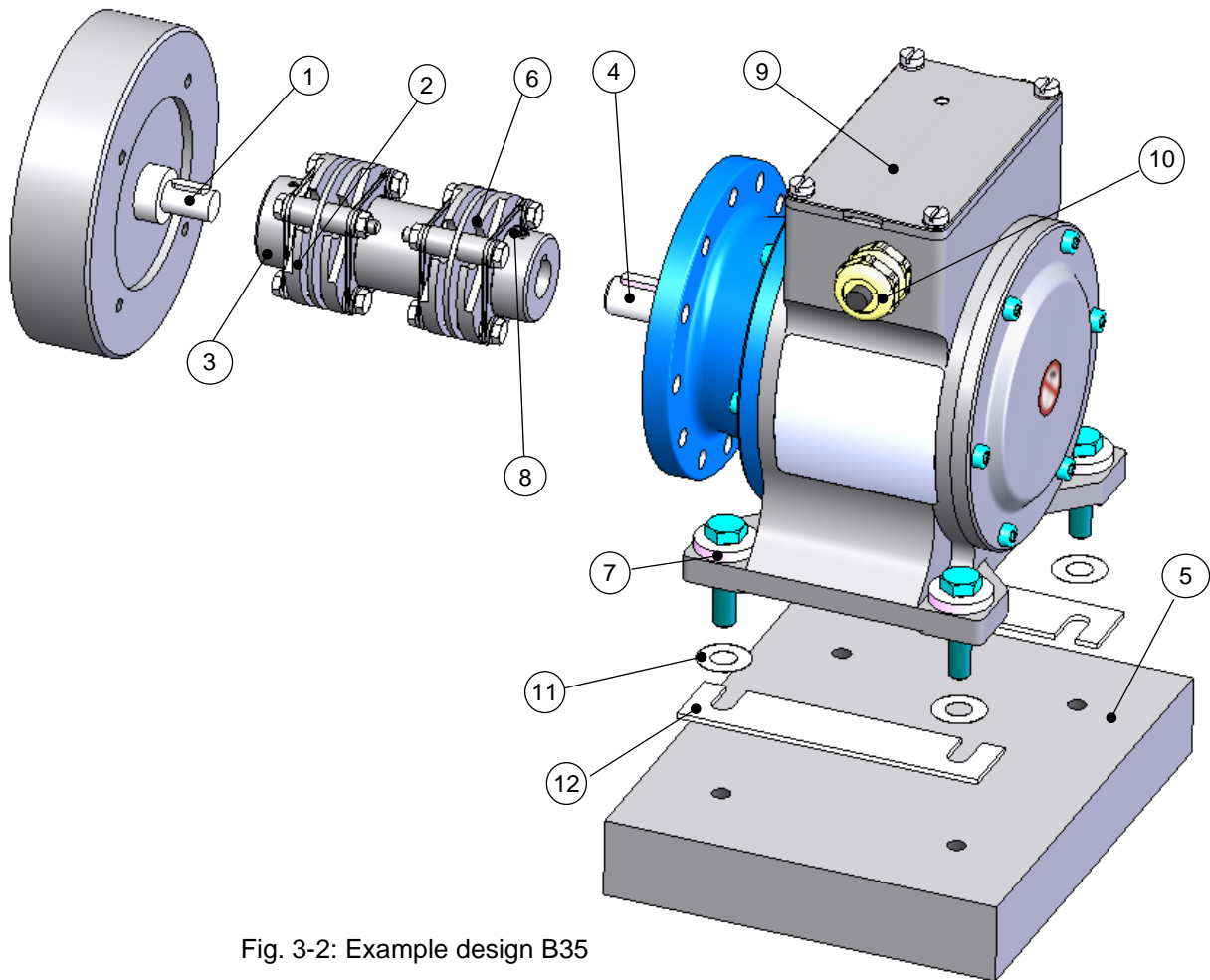



Fig. 3-2: Example design B35

1. Grease the drive shaft (1) lightly.
2. Attach the coupling hub (3) to the drive shaft (1) using a grub screw or regular screw (depending on the coupling design).
3. Grease the USL 42 shaft (4) lightly.
4. Align the shaft of the USL 42 (4) to the drive shaft (1) and mount in the coupling hub (6).
5. Attach the base of the USL 42 to the customer interface (5) using the 4 screws and washers (7) supplied. Tightning torque: 26 Nm
6. Attach the coupling hub to the shaft using a grub screw or regular screw (8) (depending on the coupling design).

	<p><b>NOTE!</b></p> <p>Mounting deviations perpendicular to the bracket (5) can be compensated with spacer plates (12). <b>Observe the notes on mounting errors and maximum permissible mounting deviations in chapter 9.4!</b></p>
	<p><b>WARNING!</b></p> <p>In the event of a shock load of &gt;20 g, friction-enhancing washers (11) must be used in the clamping surface.</p> <p>If spacer plates and friction-enhancing washers are used at the same time, the spacer plates must be secured with adhesive (shear strength min. 5 N/mm<sup>2</sup>). This applies to every contact surface in which there are no friction-enhancing washers.</p>

### Attachment screws

The following conditions must be complied for proper assembly:

Tensile strength	Screw	Tightening torque
200...229 N/mm <sup>2</sup>	M8x40 - 12.9	26 Nm
230...329 N/mm <sup>2</sup>	M8x35 - 12.9	26 Nm
> 330 N/mm <sup>2</sup>	M8x30 - 12.9	26 Nm

The screw length is based on fastening to a steel or cast iron component. Other materials may require a different screw length.



**NOTE!**

Appropriate measures must be taken if the minimum tensile strength on the screw thread of the customer interface is not observed (for instance using Ensart bushings).

### 3.2.3 Installation of hollow shaft version



**NOTE!**

- Example assembly (for dimensional drawing, see section 10). The following assembly description is only an example, and may vary depending on the type of adapter shaft used.
- The radial run-out of the adapter shaft may be a max. of 0.05 mm.
- Use the ball pressure screws to align the adapter shaft if necessary. Secure the ball pressure screws with Loctite® 243 if necessary. Remove any ball pressure screws that are not in use, or secure them with Loctite® 243 as well.
- Use keys in accordance with DIN 6885.
- The support arm (2) can be attached to the device in four different directions.
- The hollow shaft device must be able to be pushed easily onto the adapter shaft. Never used increased force to push it on; otherwise, this may damage the bearings. Rework the adapter shaft and key using emery cloth or a file if necessary. Do not strike the device hard against the shaft collar.
- The torque arm must be able to turn easily around the joint head after assembly. Failure to observe these requirements may result in bearing damage.
- The ideal angle between the support arm (2) and the torque arm (9) is 90°.
- The joint heads are maintenance-free, and must be kept free from contamination or paint.
- The use of an insulated adapter shaft is recommended to prevent shaft currents from flowing through the base unit. This is available as an accessory from Johannes Hübner Fabrik elektrischer Maschinen GmbH.



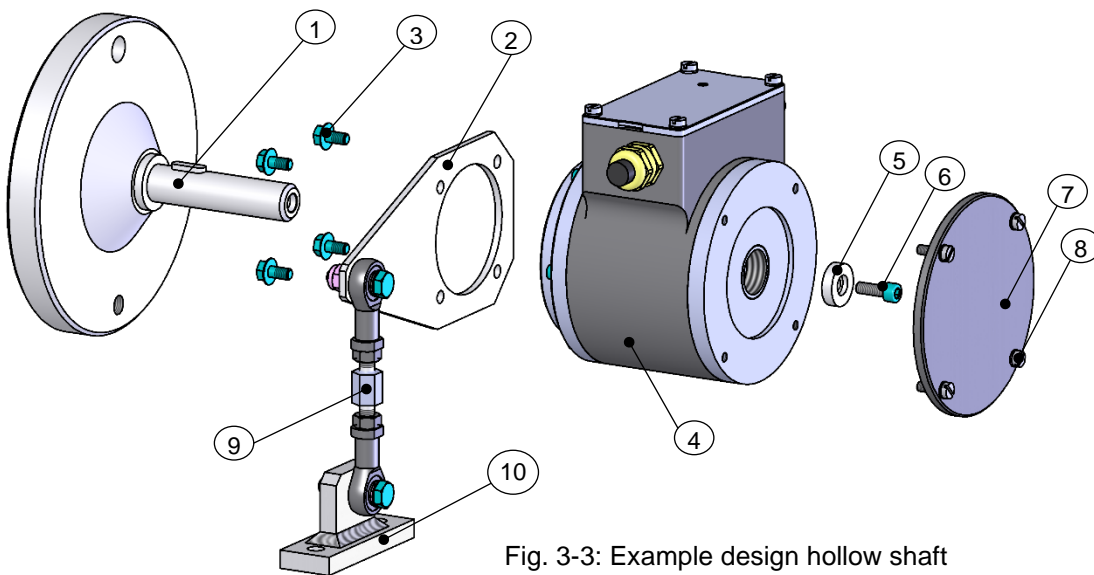

Fig. 3-3: Example design hollow shaft

1. Mount the adapter shaft (1) and align it using a dial gauge.
2. Attach the support arm (2) to the hollow shaft encoder (4) using the included Tensilock screws (3). Tightening torque: 16 Nm.
3. Loosen the 4 screws (8) to remove the cover (7).
4. Mount the hollow shaft encoder (4) onto the adapter shaft (1).
5. Secure the hollow shaft device using the enclosed axial conical spring washer (5) and cylinder screw (6) (strength class 8.8). Tightening torque: 5.4 Nm.
6. Close the hollow shaft device using the cover or assembly kit for 2nd shaft end (7) and 4 screws (8).
7. Mounting the torque support:

**Mounting without base plate:**

The free joint head of the torque arm (9) is screwed directly onto a fixed point, for instance onto the motor housing.

**Mounting with base plate:**

The base plate (10) is screwed onto a fixed point, such as the motor housing or the foundation, using screws.

### 3.3 Disassembly

Personnel

Disassembly may only be carried out by qualified personnel.

	<p><b>WARNING!</b></p> <p>Observe the safety information in section 2 during disassembly, and other work on the USL 42.</p>
---	---

	<p><b>NOTE!</b></p> <p>Using a hammer or similar tools during disassembly is not permitted, due to the danger of damage to the ball bearings and couplings.</p>
---	---

#### 3.3.1 Disassembly of the USL 42

Before disassembly, unplug all electrical connection cables for the USL 42.

Disassemble the USL 42 in the reverse order indicated in section 3.

#### 3.3.2 Exchanging the USL 42



When replacing USL 42, observe the following:

- The new USL 42 must have the same item no. (ID) as the old one.
- Install the new USL 42 according to the specifications and requirements of section 3.
- The configuration of the USL 42 to be replaced may be transferred to the new USL 42 (see configuration instructions).
- When recommissioning the replaced USL 42, a secure test run must be completed first to ensure it functions correctly.

### 3.4 Installation

#### 3.4.1 Safety instructions

	<p><b>WARNING!</b></p> <ul style="list-style-type: none"> <li>• Installation and removal may only be carried out by qualified personnel.</li> <li>• In general, the requirements and acceptance conditions of the overall system must be taken into account for the installation.</li> <li>• Equipotential bonding measures must be provided for the entire processing chain of the system. Uninterrupted, low-resistance machine earthing must be ensured across all parts of the system. Ensure that connections have good electrical contact.</li> <li>• The power supply used must not exceed 60 VDC under any circumstances.</li> <li>• When connecting the supply cable, ensure that the insulation of all cables is intact. Damaged cables must not be used.</li> <li>• When laying the cables, ensure that there are no tripping hazards.</li> </ul>
---	--

  	<p><b>DANGER! CAUTION!</b></p> <p><b>Risk of death, serious injury and/or damage to property due to overriding of the safety functions caused by an unsafe shaft drive!</b></p> <p>In general, the requirements and acceptance conditions of the entire system must be taken into account for the attachment.</p>
--	---

#### 3.4.2 Basic rules

	<p><b>NOTE!</b></p> <ul style="list-style-type: none"> <li>• The supply cable of the base unit must be laid at a sufficient distance from power and high-voltage cables.</li> <li>• Shield the power cables between the frequency inverter and motor in accordance with the manufacturer's specifications.</li> <li>• Generous mounting distances must be maintained to actuators/systems with high energy density or electromagnetic emissions (e.g. contactors, relays, inverters, motors, solenoid valves, brakes).</li> <li>• Inductors (e.g. relays, contactors, solenoid valves, brakes) must be wired with interference suppressors to minimize both conducted and airborne interference.</li> <li>• Further information on good installation practice can be found in the USL installation instructions electronics.</li> </ul>
---	---

#### 3.4.3 Connection

	<ul style="list-style-type: none"> <li>• Sufficient dimensioning of the power supply.</li> <li>• The conductor cross-section of the power supply cable must be designed so that the maximum voltage drop is less than 3 V. A wire cross-section of 0.75 mm<sup>2</sup> is recommended. Permissible cable diameter: 7 to 10.5 mm.</li> </ul>
---	---

	<ul style="list-style-type: none"> <li>• The use of a separate power supply is recommended for the U-ONE function group including its peripherals and base unit.</li> <li>• For the base unit, it is also recommended to use a remote power supply if the required cable length of the connecting cable would be more than 30 meters (guide value).</li> <li>• A shielded supply cable must be used for the electrical connection. The cable shield must be connected to the machine earthing on both sides.</li> <li>• A cable for connecting to earth potential must be connected to the earth terminal of the base unit, if not already pre-assembled (max. tightening torque 2.0 Nm).</li> <li>• A flat grounding strap consisting of fine stranded wire with a minimum cross-section of 6 mm<sup>2</sup> must be used for earthing.</li> <li>• The grounding strap must be permanently and permanently connected to a low-impedance, nearby earthing point on the system side. The earthing point must be bare metal, free of paint, non-conductive surface finishes, grease, oil and corrosion. The length of the grounding strap should not exceed 2 m.</li> <li>• Depending on the cable type used, the correct sealing insert must be inserted into the cable gland for the fiber optic connection: 5 to 8 mm, 7 to 10.5 mm or 3 mm.</li> </ul>
--	--

### **Terminal box connection steps**

1. Strip the supply cable. Suitable tools must be used to strip the insulation. The cable for the supply line is. The conductor cross-section must be at least 0.75 mm<sup>2</sup> and the cable diameter at least 7 mm. The cable for fiber optics does not have a shield. Crimp on the wire end ferrules.
2. Squeeze on wire-end ferrules.
3. Open the terminal box cover.
4. Remove the locking screws of the cable glands. The power cable gland is an EMC cable gland. The cable gland for the fiber optic cable does not have a shield connection.
5. Feed the cables through the cable glands into the terminal box.
6. The shield of the supply cable is connected directly to the housing via the EMC cable gland with conical contact.
7. Tighten the cable glands until the cables are securely clamped and sealed.
8. Connect the power supply and the fiber optic cable (see section 10.2).
9. The cable glands can be swapped if necessary. Route the cables inside the terminal box as shown in the pictures below.
10. Close the cover of the terminal box.

**NOTE!**

- Follow the connection diagram in chapter 10.2.
- No moisture may enter the terminal box when the box is open.
- Avoid tensile forces pulling the cables from the sides by ensuring the protective class of the cable glands is not negatively affected.
- Cables should be routed in the form of a loop to prevent tensile force (see image)
- Before closing the cover on the terminal box, check the sealing surface to ensure it is clean and check the seal to ensure it is complete. Clean or replace damaged seals as necessary.
- When closing the cover on the terminal box, ensure that cables do not become stuck.

i



## 4 Technical data

### 4.1 Type plate

The following image shows an example of a type plate.

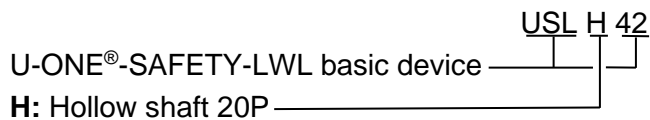

Fig. 4-1: Type plate (example)

The type plate is located on the outside of the housing, and includes the following information:

- Manufacturer, address
- Type, year of construction
- CE mark
- Serial number (S/N)
- Protective class
- Supply voltage
- ID number
- Certification information

### 4.2 Type designation



### 4.3 Mechanical data

#### 4.3.1 Solid shaft encoder

Information	Value	
Shaft load at the end of the shaft	≤ 300 N axial, ≤ 300 N radial	
Shaft end	Ø 14j6 x 30 mm Ø 11j6 x 30 mm	
Permitted speed	≤ 2800 1/min	
Working temperature (Housing temperature)	-25°C...+ 67°C	
permitted ambient temperature	See chapter 4.3.4	
Vibration resistance	10 g (DIN EN 60068-2-6:2008 (55 ... 500 Hz))	
Shock resistance, screw fitting using M8 screws	100 g (DIN EN 60068-2-27:2009 (half sine 11 ms)) from 20 g: "Friction enhancing washer" accessory set required.	
Bearing service life (see sec. 4.3.3)	3 x 10 <sup>10</sup> revolutions	
Rotor moment of inertia	approx. 330 gcm <sup>2</sup>	
Permitted angular acceleration	≤ 10 <sup>4</sup> rad/s <sup>2</sup>	
Breakaway torque	approx. 3.5 Ncm	
Protective class in accordance with DIN EN 60529	IP66	
Elevation above sea level	≤ 3000 m	
Result. Noise emission level	< 70 dB(A)	
Weight	Design B5 Design B35	approx. 3.6 kg approx. 3.8 kg

#### 4.3.2 Hollow shaft encoder

Information	Value
Interior diameter	20 with keyway
Permitted speed	≤ 2800 1/min
Working temperature (Housing temperature)	-25°C...+ 67°C
permitted ambient temperature	See chapter 4.3.4
Vibration resistance	10 g (DIN EN 60068-2-6:2008 (55 ... 500 Hz))
Shock resistance	100 g (DIN EN 60068-2-27:2009 (half sine 11 ms))
Bearing service life (see sec. 4.3.3)	1.2 x 10 <sup>11</sup> revolutions
Rotor moment of inertia	approx. 785 gcm <sup>2</sup>
Permitted angular acceleration	≤ 10 <sup>4</sup> rad/s <sup>2</sup>
Breakaway torque	approx. 3.5 Ncm
Protective class in accordance with DIN EN 60529	IP66
Noise emission level	< 70 dB(A)
Max. elevation above sea level	≤ 3000 m
Weight	approx. 3.8 kg

#### 4.3.3 Bearing service life

The service lives indicated are based on the calculation specifications of ISO/TS 16282, with the following assumptions:

Continuous load throughout service life: 2000 1/min, 55°C

this means that the likelihood that the bearing will continue to function is 90%, based on the given service lives.

**The following factors influence the service life of the bearing:**

- Operating temperature
- Operating speed
- Mechanical load due to vibrations and shocks
- Drive dynamics
- Influences of transportation and storage (bearing grease ageing)
- Installation errors



#### 4.3.4 Speed derating

The following derating curves are based on the average device speed.

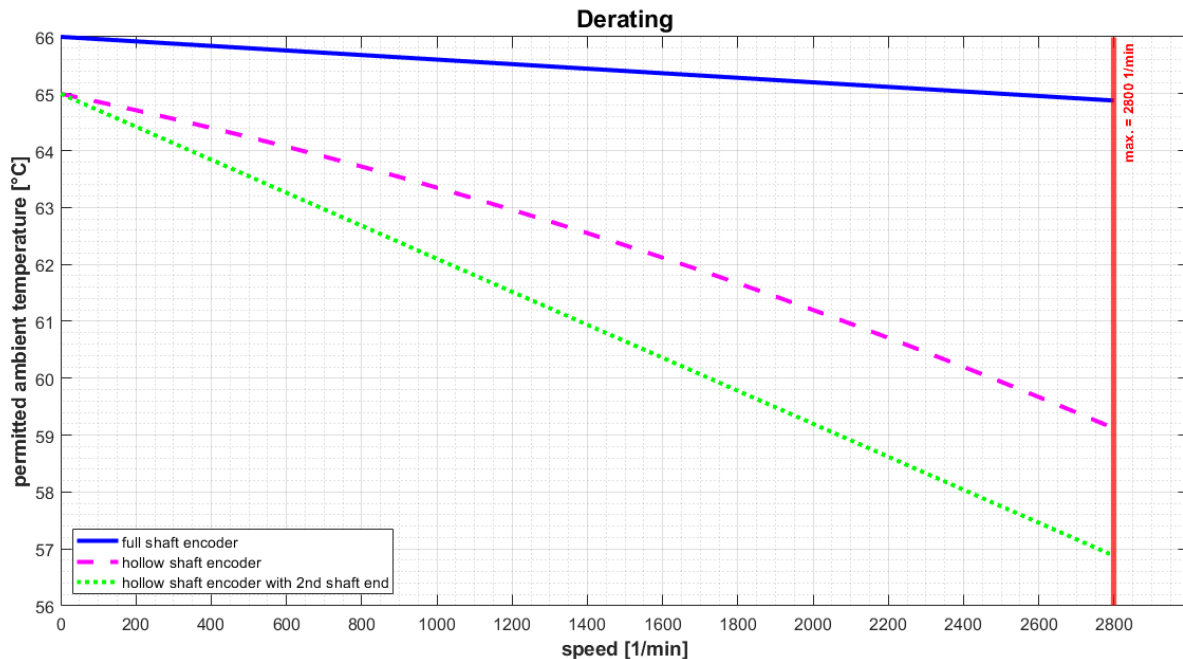

#### 4.4 Electrical data

Information	Value
Supply voltage	15 V...27 VDC CAUTION: 60 VDC must not be exceeded under any circumstances (even in the event of a fault).
Power consumption	< 5 W
Connection technology	Screw terminals 0.25 mm <sup>2</sup> - 1.5 mm <sup>2</sup>
Total resolution	28 Bit
Singleturn functional	13 Bit (8192 steps/revolution)
Singleturn safety-related	8 Bit (256 steps/revolution)
Multiturn	15 Bit (32768 revolutions)
Incremental functional	4096 pulses/revolution
Fibre optic cable output	Multimode, gradient index fibre 50/125µm or 62.5/125µm
Transmission length	≤ 1000 m
Connection technology	ST plug connector
Connection diagram	see chapter 10.2.

#### 4.5 Operating modes and displays

Operating mode	Status LED
<b>Start</b>	Flashing yellow/green 2 Hz
<b>Normal</b>	Green
<b>Bootloader</b>	Flashing yellow/red 1 Hz
<b>Warning</b>	Flashing yellow 1 Hz
<b>Error</b>	Red

#### **Warning**

A warning is generated:

The USL 42 has reached the end of its service life (20 years). After this time, it may no longer be used for safety-related functions.

## 5 Structure and function

The USL 42 consists of:

- A two-channel sensing system for producing reliable measurement data through internal channel comparison,
- A system 1 (master system): optical Single-turn sensing via code disk with transmitted light and magnetic Multi-Turn sensing,
- A system 2 (test system): magnetic Single and Multi-Turn sensing,
- A common drive shaft.

The optical system is more precise from a technological standpoint, which is why it is used as the master system.

The magnetic sensing system is used for internal safety monitoring. Two-channel data comparison ensures the data is "reliable".

The integrated fibre optic cable interface transmits encoder data to the UO-SCU function module without errors. In addition, electronic type plate and diagnostic data are also transmitted.

Data is then available in the UO-SCU function module as electrical signals.

## 6 Functional safety

### 6.1 Safety parameters

Parameters set for the USL 42 according to DIN EN ISO 13849-1.

Architec- ture	Category	PL	MTTF <sub>D</sub> [a]	Service life
1oo2 (2-channel)	3	d	203,9	20 years

Parameters set for the USL 42 according to IEC 61508 and DIN EN 62061.

PFD <sub>AV</sub>	PFH [FIT]	DC <sub>avg</sub> [%]	SIL
3.69E-05	0.42	98.1	2 (high de- mand)

Calculations for the safety parameters of the overall system are provided in the configuration manual.

### 6.2 Information on functional safety



#### **CAUTION!**

- The user must ensure that the max. number of steps for the basic device is not exceeded when the device is switched off.
- The USB interface is only designed for firmware updates.

## 7 Inspections

### 7.1 Safety information



**NOTE / PERSONNEL**

Only qualified personnel may inspect the USL 42 and its installation. Observe the safety information in **section 2** during inspection and other work on the USL 42.

### 7.2 Maintenance information

The USL 42 is maintenance-free. However, the following inspections are recommended to ensure optimal, fault-free operation.

The inspections described here may be carried out only by technicians. Please observe, in particular, operational and operator-relevant UV regulations, machine and system protection laws and application and country-specific specifications, laws and standards.

### 7.3 Inspection plan



**NOTE!**

No further work is required on the USL 42, beyond the regular inspections described in the following inspection plan. Any modifications to the USL 42 will result in a loss of all warranty claims!

Interval	Inspections
Annual	Check coupling to ensure it is free from play and damage
	Check the attachment screws to ensure they are tight
	Check cable connections and terminals to ensure they are tight
	Check the blind plugs to ensure they are sealed properly
	Check labels and type plates to ensure they are legible
After approx. 16,000 to 20,000 operating hours or heavy continuous loads	Check ball bearings to ensure they run smoothly and quietly. Ball bearings may only be replaced by the manufacturer.

## 8 Transportation, packaging and storage

### 8.1 Transportation safety information

<b>!</b>	<p><b>CAUTION!</b> <b>Property damage due to improper transportation!</b></p> <p>These symbols and information on the packaging must be observed: Do not throw, danger of breakage Protect against wetness Protect against temperatures over 40°C and direct sunlight</p>
----------	---

### 8.2 Incoming goods controlling

The delivery must be checked promptly for transportation damage and to ensure it is complete upon receipt.

If there is transportation damage, the carrier must be informed directly upon delivery. (Take photos as evidence).

### 8.3 Packaging (disposal)

Packaging will not be taken back, and must be disposed of according to applicable statutory specifications and local regulations.

### 8.4 Storing packages (devices)

	<p><b>Protect against wetness!</b> Protect packages against wetness, store in a dry and dust-free location.</p>
---	---

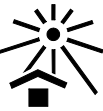
	<p><b>Protect against heat</b> Protect packages against temperatures over 40°C and direct sunlight</p>
---	--

In case of long storage times (> 6 months), we recommend packaging the devices in protective packaging (with desiccants).

	<p><b>NOTE!</b> Turn the shaft of the USL 42 every 6 months to prevent the grease from solidifying.</p>
---	---

### 8.5 Returning equipment (repair/goodwill/warranty)

Service requests (repair/goodwill/warranty) can be initiated directly via the following online form:

<https://www.huebner-giessen.com/en/service-support/after-sales-service/>

There you will also find contact details for our service, as well as questions and answers regarding the processing.

Devices that have come into contact with radioactive radiation or materials will not be taken back.

Devices that have come into contact with biological or chemical substances that could be hazardous to health must be decontaminated before they are returned. A clearance certificate must be enclosed.

## **8.6 Disposal**

The manufacturer is not obligated to take back the devices.

The USL 42 must be treated as special electronic waste, and must be disposed of according to specific national law.

Local municipal authorities or speciality disposal companies can provide information on environmentally-appropriate disposal.

## 9 Accessories

In addition, we offer matching accessories and customised engineering support to ensure the safe and secure installation of our rotary encoder systems.

Functional, safe installation can only be completed with appropriately designed mechanical accessories. We offer the safe installation components needed for assembly, with fault exclusion in accordance with the Machinery Directive 2006/42/EC. We will provide a declaration of conformity to verify the fatigue strength and design strength of the device, as well as to confirm that it complies with relevant safety standards. This greatly simplifies the internal risk assessment and acceptance of your system.

### 9.1 Safety-integrated solid shaft installation

We offer the following safety components, designed to fit in their individual installation sites, with declarations of conformity to ensure safe installation of the solid shaft:

#### Flange installation:

- Safety couplings (single or double jointed couplings) with keyways for secure, positive-locking connection
- Safety intermediate flange incl. matching adapter disc to the mechanical interface of the machine housing

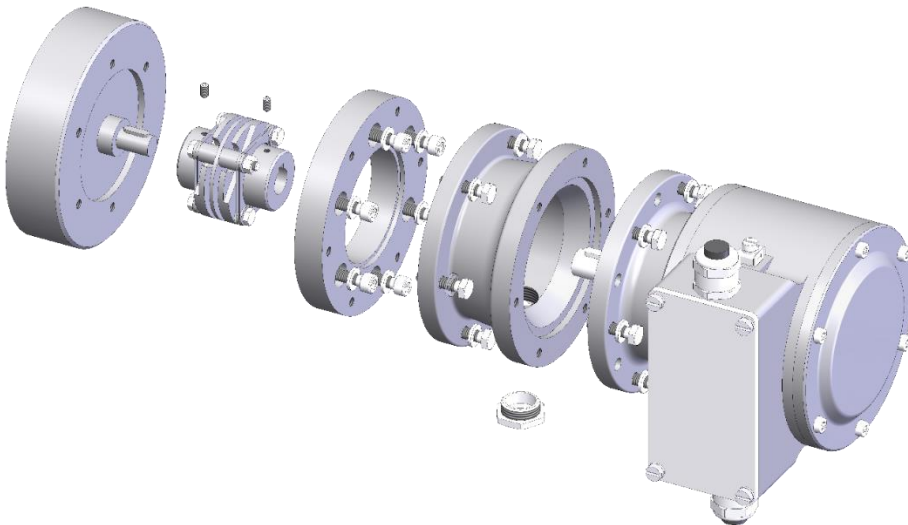

**Base installation:**

- Friction-enhancing washers and spacer plates
- Safety couplings (single or double jointed couplings) with keyways for secure, positive-locking connection

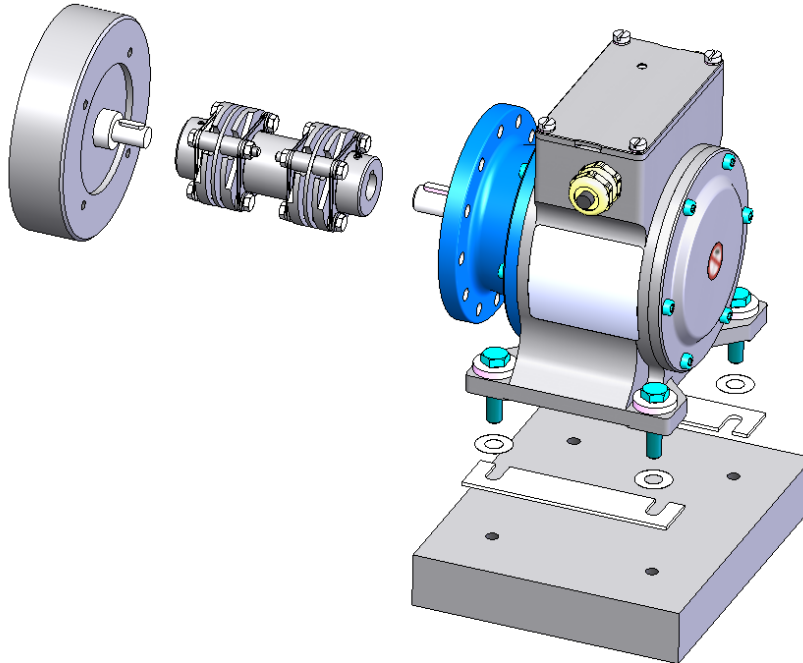

**9.2 Safety-integrated hollow shaft installation**

We offer the following safety components, designed to fit in their individual installation sites, with declarations of conformity to ensure safe installation of the hollow shaft:

- Safety adapter shafts (flange or screw-in adapter shafts with keyways for secure, positive-locking connection)
- Safety torque supports with appropriate support arm and support lengths

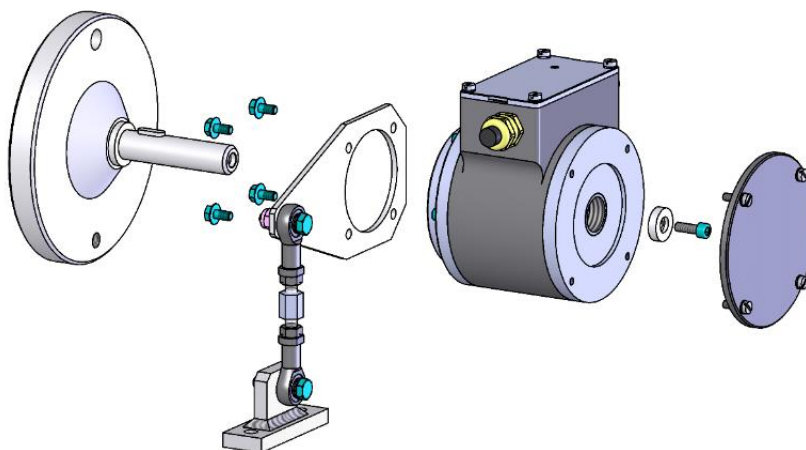

**9.3 Cable protection systems**

We offer specially designed cable protection systems with screw fittings and sealing inserts, as well as integrated shielding and strain relief in order to provide optimal protection for rotary encoder wiring (copper, fibre optic cable) in extreme ambient conditions.



#### 9.4 Couplings for safety-integrated solid shaft installation

We recommend our play-free, torsion-resistant HK(D)S 5 couplings with fault exclusion to install the USL 42.

The couplings fulfill the following requirements:

Information		Value	
Shock resistance	(DIN EN 60068-2-27 (6 ms))	100 g	
Vibration resistance	(DIN EN 60068-2-6 (8.7 ... 2000 Hz))	20 g	
Torque		3 Nm	
Temperature range		-25°... +85° C	
Max. speed		6000 1/min	
Installation precision	HKS 5 / HKSI 5:	Axial offset:	± 1 mm
		Angle:	0.5°
	HKDS 5 / HKDSI 5:	Axial offset:	± 1.5 mm
		Radial offset:	± 0.5 mm

Our Sales department will be happy to provide you with further information.

**10 Documents**

**10.1 Dimensional drawings**

HM 19 M 114502a

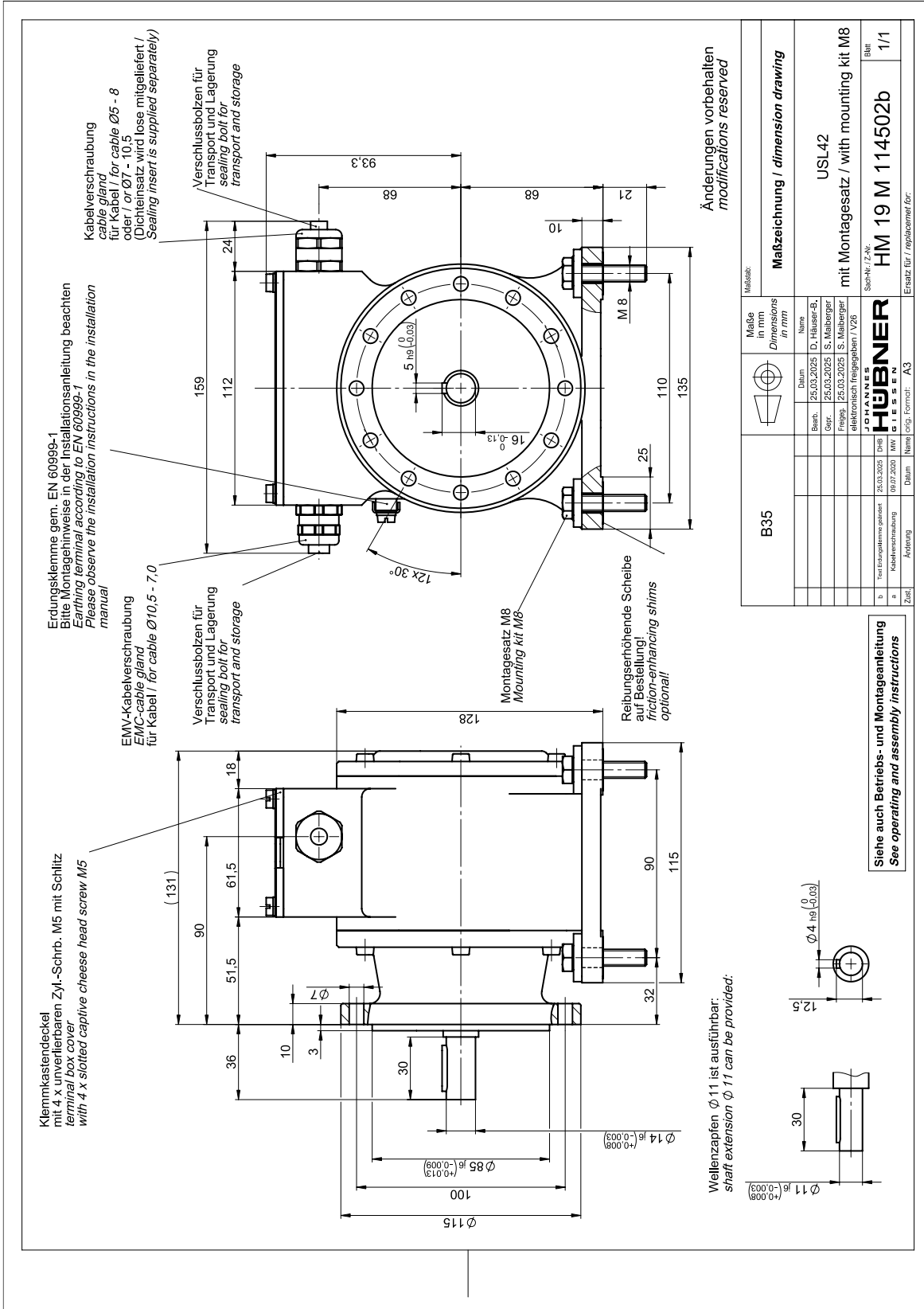

HM 19 M 113975a

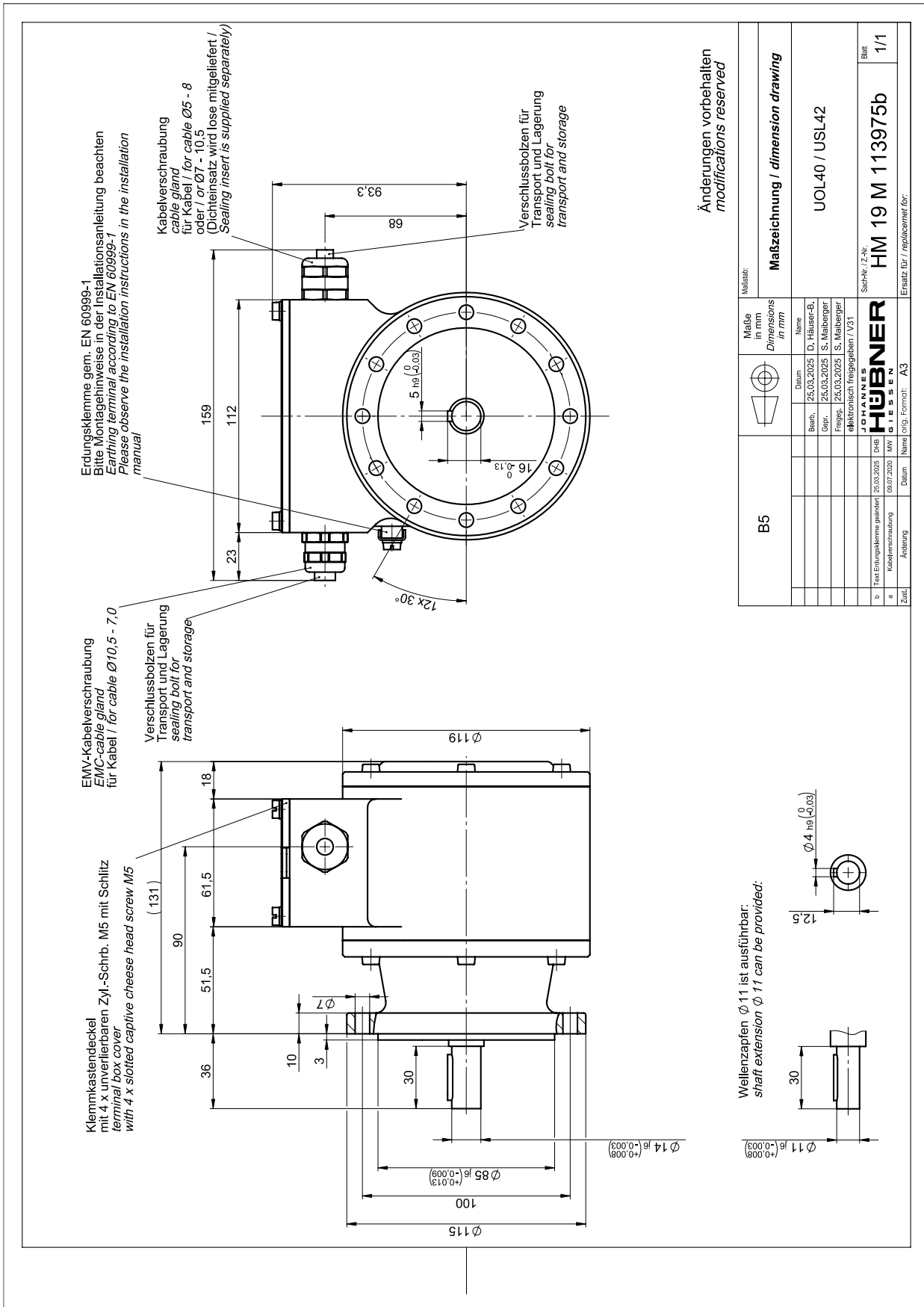

HM 19 M 113552b

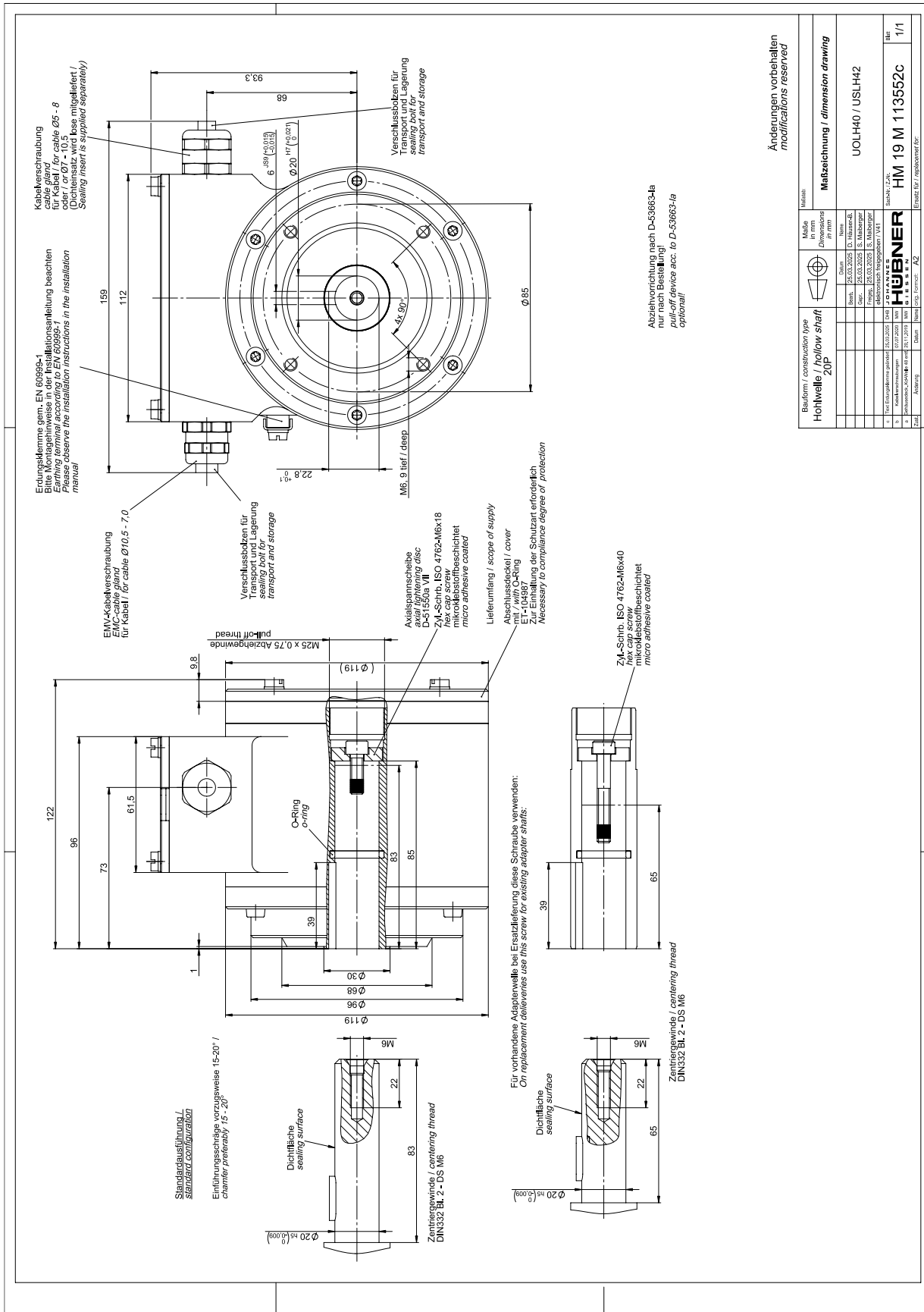

Änderungen vorbehalten  
modifications reserved

Bauteil / construction type <b>Hohlwelle / hollow shaft</b> ZÖP		Maße Max. in mm Dimensions in mm	
Best.-Nr.	25.03.2025	Ø-Teilname	Ø
Rev.	25.03.2025	S. Maßstabsgr.	1:1
Proj.	25.03.2025	S. Maßstabgr.	1:1
Abnehmerrückmeldung / M1		Maßstab / Scale	
1. Teil-Geometrie (0,001)		HM 19 M 113552C	
2. Teil-Geometrie (0,001)		1/1	
3. Geometrie (0,001)		1/1	
4. Geometrie (0,001)		1/1	
5. Geometrie (0,001)		1/1	
6. Geometrie (0,001)		1/1	
7. Geometrie (0,001)		1/1	
8. Geometrie (0,001)		1/1	
9. Geometrie (0,001)		1/1	
10. Geometrie (0,001)		1/1	
11. Geometrie (0,001)		1/1	
12. Geometrie (0,001)		1/1	
13. Geometrie (0,001)		1/1	
14. Geometrie (0,001)		1/1	
15. Geometrie (0,001)		1/1	
16. Geometrie (0,001)		1/1	
17. Geometrie (0,001)		1/1	
18. Geometrie (0,001)		1/1	
19. Geometrie (0,001)		1/1	
20. Geometrie (0,001)		1/1	
21. Geometrie (0,001)		1/1	
22. Geometrie (0,001)		1/1	
23. Geometrie (0,001)		1/1	
24. Geometrie (0,001)		1/1	
25. Geometrie (0,001)		1/1	
26. Geometrie (0,001)		1/1	
27. Geometrie (0,001)		1/1	
28. Geometrie (0,001)		1/1	
29. Geometrie (0,001)		1/1	
30. Geometrie (0,001)		1/1	
31. Geometrie (0,001)		1/1	
32. Geometrie (0,001)		1/1	
33. Geometrie (0,001)		1/1	
34. Geometrie (0,001)		1/1	
35. Geometrie (0,001)		1/1	
36. Geometrie (0,001)		1/1	
37. Geometrie (0,001)		1/1	
38. Geometrie (0,001)		1/1	
39. Geometrie (0,001)		1/1	
40. Geometrie (0,001)		1/1	
41. Geometrie (0,001)		1/1	
42. Geometrie (0,001)		1/1	
43. Geometrie (0,001)		1/1	
44. Geometrie (0,001)		1/1	
45. Geometrie (0,001)		1/1	
46. Geometrie (0,001)		1/1	
47. Geometrie (0,001)		1/1	
48. Geometrie (0,001)		1/1	
49. Geometrie (0,001)		1/1	
50. Geometrie (0,001)		1/1	
51. Geometrie (0,001)		1/1	
52. Geometrie (0,001)		1/1	
53. Geometrie (0,001)		1/1	
54. Geometrie (0,001)		1/1	
55. Geometrie (0,001)		1/1	
56. Geometrie (0,001)		1/1	
57. Geometrie (0,001)		1/1	
58. Geometrie (0,001)		1/1	
59. Geometrie (0,001)		1/1	
60. Geometrie (0,001)		1/1	
61. Geometrie (0,001)		1/1	
62. Geometrie (0,001)		1/1	
63. Geometrie (0,001)		1/1	
64. Geometrie (0,001)		1/1	
65. Geometrie (0,001)		1/1	
66. Geometrie (0,001)		1/1	
67. Geometrie (0,001)		1/1	
68. Geometrie (0,001)		1/1	
69. Geometrie (0,001)		1/1	
70. Geometrie (0,001)		1/1	
71. Geometrie (0,001)		1/1	
72. Geometrie (0,001)		1/1	
73. Geometrie (0,001)		1/1	
74. Geometrie (0,001)		1/1	
75. Geometrie (0,001)		1/1	
76. Geometrie (0,001)		1/1	
77. Geometrie (0,001)		1/1	
78. Geometrie (0,001)		1/1	
79. Geometrie (0,001)		1/1	
80. Geometrie (0,001)		1/1	
81. Geometrie (0,001)		1/1	
82. Geometrie (0,001)		1/1	
83. Geometrie (0,001)		1/1	
84. Geometrie (0,001)		1/1	
85. Geometrie (0,001)		1/1	
86. Geometrie (0,001)		1/1	
87. Geometrie (0,001)		1/1	
88. Geometrie (0,001)		1/1	
89. Geometrie (0,001)		1/1	
90. Geometrie (0,001)		1/1	
91. Geometrie (0,001)		1/1	
92. Geometrie (0,001)		1/1	
93. Geometrie (0,001)		1/1	
94. Geometrie (0,001)		1/1	
95. Geometrie (0,001)		1/1	
96. Geometrie (0,001)		1/1	
97. Geometrie (0,001)		1/1	
98. Geometrie (0,001)		1/1	
99. Geometrie (0,001)		1/1	
100. Geometrie (0,001)		1/1	
101. Geometrie (0,001)		1/1	
102. Geometrie (0,001)		1/1	
103. Geometrie (0,001)		1/1	
104. Geometrie (0,001)		1/1	
105. Geometrie (0,001)		1/1	
106. Geometrie (0,001)		1/1	
107. Geometrie (0,001)		1/1	
108. Geometrie (0,001)		1/1	
109. Geometrie (0,001)		1/1	
110. Geometrie (0,001)		1/1	
111. Geometrie (0,001)		1/1	
112. Geometrie (0,001)		1/1	
113. Geometrie (0,001)		1/1	
114. Geometrie (0,001)		1/1	
115. Geometrie (0,001)		1/1	
116. Geometrie (0,001)		1/1	
117. Geometrie (0,001)		1/1	
118. Geometrie (0,001)		1/1	
119. Geometrie (0,001)		1/1	
120. Geometrie (0,001)		1/1	
121. Geometrie (0,001)		1/1	
122. Geometrie (0,001)		1/1	
123. Geometrie (0,001)		1/1	
124. Geometrie (0,001)		1/1	
125. Geometrie (0,001)		1/1	
126. Geometrie (0,001)		1/1	
127. Geometrie (0,001)		1/1	
128. Geometrie (0,001)		1/1	
129. Geometrie (0,001)		1/1	
130. Geometrie (0,001)		1/1	
131. Geometrie (0,001)		1/1	
132. Geometrie (0,001)		1/1	
133. Geometrie (0,001)		1/1	
134. Geometrie (0,001)		1/1	
135. Geometrie (0,001)		1/1	
136. Geometrie (0,001)		1/1	
137. Geometrie (0,001)		1/1	
138. Geometrie (0,001)		1/1	
139. Geometrie (0,001)		1/1	
140. Geometrie (0,001)		1/1	
141. Geometrie (0,001)		1/1	
142. Geometrie (0,001)		1/1	
143. Geometrie (0,001)		1/1	
144. Geometrie (0,001)		1/1	
145. Geometrie (0,001)		1/1	
146. Geometrie (0,001)		1/1	
147. Geometrie (0,001)		1/1	
148. Geometrie (0,001)		1/1	
149. Geometrie (0,001)		1/1	
150. Geometrie (0,001)		1/1	
151. Geometrie (0,001)		1/1	
152. Geometrie (0,001)		1/1	
153. Geometrie (0,001)		1/1	
154. Geometrie (0,001)		1/1	
155. Geometrie (0,001)		1/1	
156. Geometrie (0,001)		1/1	
157. Geometrie (0,001)		1/1	
158. Geometrie (0,001)		1/1	
159. Geometrie (0,001)		1/1	
160. Geometrie (0,001)		1/1	
161. Geometrie (0,001)		1/1	
162. Geometrie (0,001)		1/1	
163. Geometrie (0,001)		1/1	
164. Geometrie (0,001)		1/1	
165. Geometrie (0,001)		1/1	
166. Geometrie (0,001)		1/1	
167. Geometrie (0,001)		1/1	
168. Geometrie (0,001)		1/1	
169. Geometrie (0,001)		1/1	
170. Geometrie (0,001)		1/1	
171. Geometrie (0,001)		1/1	
172. Geometrie (0,001)		1/1	
173. Geometrie (0,001)		1/1	
174. Geometrie (0,001)		1/1	
175. Geometrie (0,001)		1/1	
176. Geometrie (0,001)		1/1	
177. Geometrie (0,001)		1/1	
178. Geometrie (0,001)		1/1	
179. Geometrie (0,001)		1/1	
180. Geometrie (0,001)		1/1	
181. Geometrie (0,001)		1/1	
182. Geometrie (0,001)		1/1	
183. Geometrie (0,001)		1/1	
184. Geometrie (0,001)		1/1	
185. Geometrie (0,001)		1/1	
186. Geometrie (0,001)		1/1	
187. Geometrie (0,001)		1/1	
188. Geometrie (0,001)		1/1	
189. Geometrie (0,001)		1/1	
190. Geometrie (0,001)		1/1	
191. Geometrie (0,001)		1/1	
192. Geometrie (0,001)		1/1	
193. Geometrie (0,001)		1/1	
194. Geometrie (0,001)		1/1	
195. Geometrie (0,001)		1/1	
196. Geometrie (0,001)		1/1	
197. Geometrie (0,001)		1/1	
198. Geometrie (0,001)		1/1	
199. Geometrie (0,001)		1/1	
200. Geometrie (0,001)		1/1	
201. Geometrie (0,001)		1/1	
202. Geometrie (0,001)		1/1	
203. Geometrie (0,001)		1/1	
204. Geometrie (0,001)		1/1	
205. Geometrie (0,001)		1/1	
206. Geometrie (0,001)		1/1	
207. Geometrie (0,001)		1/1	
208. Geometrie (0,001)		1/1	
209. Geometrie (0,001)		1/1	
210. Geometrie (0,001)		1/1	
211. Geometrie (0,001)		1/1	
212. Geometrie (0,001)		1/1	
213. Geometrie (0,001)		1/1	
214. Geometrie (0,001)		1/1	
215. Geometrie (0,001)		1/1	
216. Geometrie (0,001)		1/1	
217. Geometrie (0,001)		1/1	
218. Geometrie (0,001)		1/1	
219. Geometrie (0,001)		1/1	
220. Geometrie (0,001)		1/1	
221. Geometrie (0,001)		1/1	
222. Geometrie (0,001)		1/1	
223. Geometrie (0,001)		1/1	
224. Geometrie (0,001)		1/1	
225. Geometrie (0,001)		1/1	
226. Geometrie (0,001)		1/1	
227. Geometrie (0,001)		1/1	
228. Geometrie (0,001)		1/1	
229. Geometrie (0,001)		1/1	
230. Geometrie (0,001)		1/1	
231. Geometrie (0,001)		1/1	
232. Geometrie (0,001)		1/1	
233. Geometrie (0,001)		1/1	
234. Geometrie (0,001)		1/1	
235. Geometrie (0,001)		1/1	
236. Geometrie (0,001)		1/1	
237. Geometrie (0,001)		1/1	
238. Geometrie (0,001)		1/1	
239. Geometrie (0,001)		1/1	
240. Geometrie (0,001)		1/1	
241. Geometrie (0,001)		1/1	
242. Geometrie (0,001)		1/1	
243. Geometrie (0,001)		1/1	
244. Geometrie (0,001)		1/1	
245. Geometrie (0,001)		1/1	
246. Geometrie (0,001)		1/1	
247. Geometrie (0,001)		1/1	
248. Geometrie (0,001)		1/1	
249. Geometrie (0,001)		1/1	
250. Geometrie (0,001)		1/1	
251. Geometrie (0,001)		1/1	
252. Geometrie (0,001)		1/1	
253. Geometrie (0,001)		1/1	
254. Geometrie (0,001)		1/1	
255. Geometrie (0,001)		1/1	
256. Geometrie (0,001)		1/1	
257. Geometrie (0,001)		1/1	
258. Geometrie (0,001)		1/1	
259. Geometrie (0,001)		1/1	
260. Geometrie (0,001)		1/1	
261. Geometrie (0,001)		1/1	
262. Geometrie (0,001)		1/1	
263. Geometrie (0,001)		1/1	
264. Geometrie (0,001)		1/1	
265. Geometrie (0,001)		1/1	
266. Geometrie (0,001)		1/1	
267. Geometrie (0,001)		1/1	
268. Geometrie (0,001)		1/1	
269. Geometrie (0,0			

HM 19 M 114598c

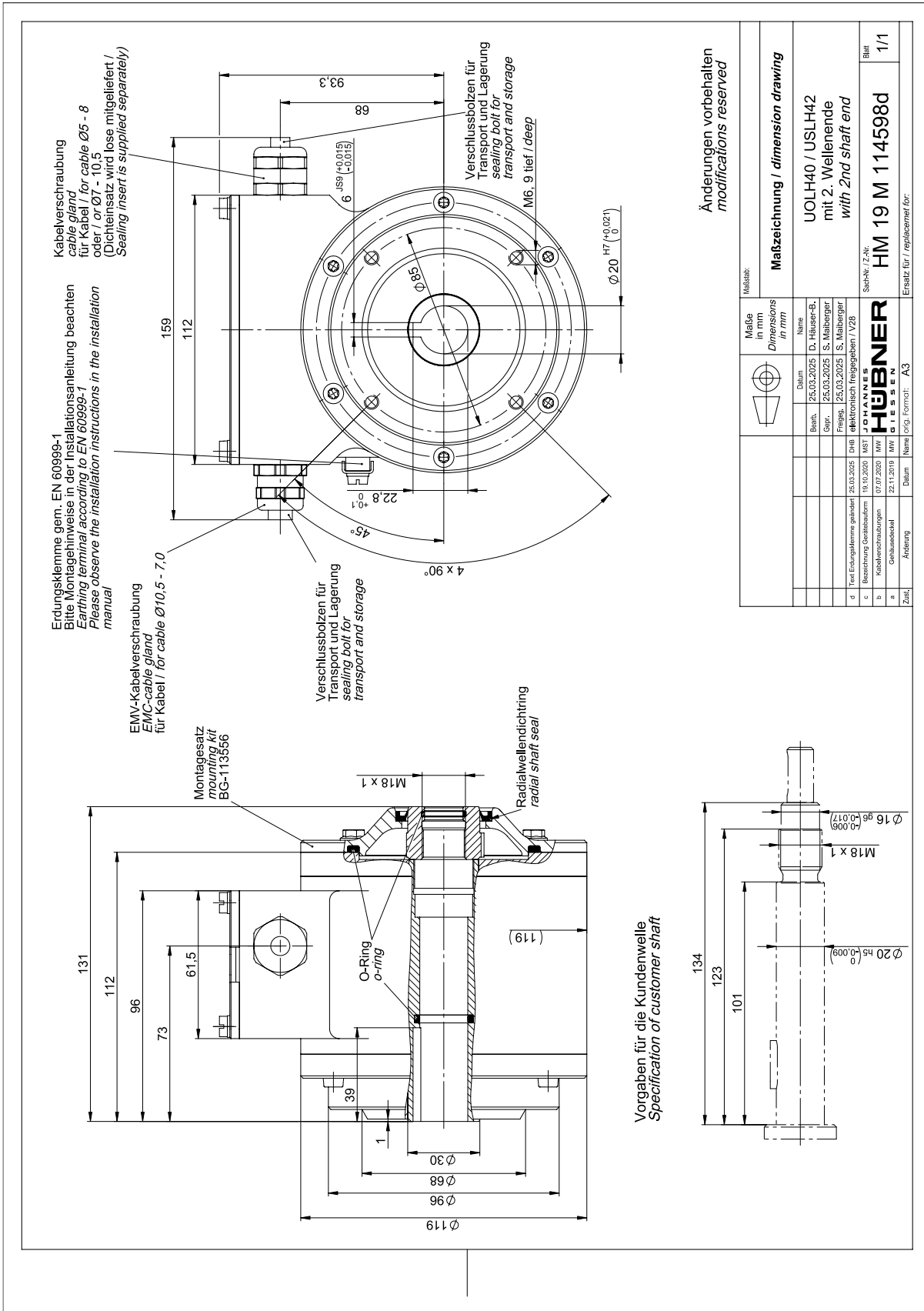

### 10.2 Connection diagram

U-ONE-Safety-LWL / Basic Unit Connection diagram PN165-410		
1	0V	GND
2	15...27V DC	Power Supply
3	LWL	Fiber Optic Cable

