

# Operating and Assembly Instructions

## Incremental Encoder FG INOX

**Read the Operating and Assembly Instructions prior to assembly, starting installation and handling!  
Keep for future reference!**



## Trademark

Brand names and product names are trademarks or registered trademarks of their respective owner. Protected trademarks bearing a <sup>TM</sup> or ® symbol are not always depicted as such in the manual. However, the statutory rights of the respective owners remain unaffected.

## Manufacturer / publisher

Johannes Hübner  
Fabrik elektrischer Maschinen GmbH  
Siemensstraße 7  
35394 Giessen  
Germany  
Phone: +49 641 7969 0  
Fax: +49 641 73645  
Internet: www.huebner-giessen.com  
E-Mail: info@huebner-giessen.com

The manual has been drawn up with the utmost care and attention. Nevertheless, we cannot exclude the possibility of errors in form and content. It is strictly forbidden to reproduce this publication or parts of this publication in any form or by any means without the prior written permission of Johannes Hübner Fabrik elektrischer Maschinen GmbH.

Subject to errors and changes due to technical improvements.

Copyright © Johannes Hübner  
Fabrik elektrischer Maschinen GmbH  
All rights reserved.

Johannes Hübner Fabrik elektrischer Maschinen GmbH is listed by Underwriters Laboratories.

UL certificates can be requested from us.

An overview of our UL devices can be found at the following link:

**<https://iq.ulprospector.com/info>**

**UL File Number: E351535**

**UL model No. ASYH 40 Z-XXXX**

Type	UL model No.
FG INOX (solid shaft)	FG INOX
FGHJ INOX (hollow shaft)	FGHJ INOX

## Directory

<b>1</b>	<b>General</b>	<b>5</b>
1.1	Information about the Operating and Assembly instructions	5
1.2	Scope of delivery	5
1.3	Explanation of symbols	5
1.4	Disclaimer	6
1.5	Copyright	6
1.6	Guarantee terms	6
1.7	Customer service	6
<b>2</b>	<b>Safety</b>	<b>6</b>
2.1	Responsibility of the owner	6
2.2	Personnel	6
2.3	Intended use	7
2.4	Improper use	7
2.5	Personal protective equipment	7
2.6	Special dangers	8
2.6.1	Electrical current	8
2.6.2	Rotating shafts / Hot surfaces	8
2.6.3	Safeguarding against restart	8
<b>3</b>	<b>Technical Data</b>	<b>9</b>
3.1	Type plate	9
3.2	Electrical and mechanical data	10
3.3	Signal outputs	11
<b>3.4</b>	<b>Operating states</b>	<b>11</b>
<b>4</b>	<b>Overview additional options</b>	<b>11</b>
4.1	Option S (overspeed switch)	11
4.2	Option LWL (signal transmission using fiber optics)	11
4.3	Type code	12
<b>5</b>	<b>Transport, packaging and storage</b>	<b>13</b>
5.1	Safety instructions for transport	13
5.2	Incoming goods inspection	13
5.3	Packaging / disposal	13
5.4	Storage of packages (devices)	13
<b>6</b>	<b>Mounting and commissioning</b>	<b>14</b>
6.1	Safety instructions	14
6.2	Technical information	14
6.3	Required tools	14
6.4	Mounting preparations	15
6.5	Mounting of incremental encoder	15
6.6	Permissible mounting deviations	17
6.7	Electrical connection and start up	18

6.7.1 Preparing cables .....	18
6.7.2 Electrical connection.....	18
<b>7 Dismantling .....</b>	<b>19</b>
7.1 Safety instructions.....	19
7.2 Dismantling the encoder .....	19
<b>8 Faults .....</b>	<b>20</b>
8.1 Faults table .....	20
<b>9 Inspections.....</b>	<b>21</b>
9.1 Safety instructions.....	21
9.2 Maintenance information .....	21
9.3 Inspection schedule .....	21
<b>10 Disposal.....</b>	<b>21</b>
10.1 Disposal procedure .....	21
<b>11 Replacement parts.....</b>	<b>21</b>
<b>12 Dimension drawings.....</b>	<b>22</b>
<b>13 Connection diagrams .....</b>	<b>26</b>
13.1 Terminal box .....	26

## 1 General

### 1.1 Information about the Operating and Assembly instructions

These Operating and Assembly Instructions provide important instructions for working with the device. They must be carefully read prior to starting all tasks, and the instructions contained herein must be followed.

In addition, applicable local regulations for the prevention of industrial accidents and general safety regulations must be complied with.

### 1.2 Scope of delivery

Incremental Encoder FG INOX, Operating and Assembly Instructions, declaration of conformity and special tools for opening and closing the encoder according to ID. card.

### 1.3 Explanation of symbols

Warnings are indicated by symbols in these Operating and Assembly Instructions. The warnings are introduced by signal words that express the scope of the hazard.

The warnings must be strictly heeded; you must act prudently to prevent accidents, personal injury, and property damage.



#### **WARNING!**

Indicates a possibly dangerous situation that can result in death or serious injury if it is not avoided.



#### **CAUTION!**

Indicates a possibly dangerous situation that can result in minor injury if it is not avoided.



#### **CAUTION!**

Indicates a possibly dangerous situation that can result in material damage if it is not avoided.



#### **NOTES!**

Indicates useful tips and recommendations as well as information for efficient and trouble-free operation.



#### **NOTES!**

Do not use a hammer or similar tool when installing the device due to the risk of damage occurring to the bearings or coupling!



#### **DANGER!**

##### **Life-threatening danger due to electric shock!**

Indicates a life-threatening situation due to electric shock. If the safety instructions are not complied with there is danger of serious injury or death. The work that must be executed should only be performed by a qualified electrician.

## 1.4 Disclaimer

All information and instructions in these Operating and Assembly Instructions have been provided under due consideration of applicable guidelines, as well as our many years of experience.

The manufacturer assumes no liability for damages due to:

- Failure to follow the instructions in the Operating and Assembly Instructions
- Non-intended use
- Deployment of untrained personnel
- Opening of the device or conversions of the device

In all other aspects the obligations agreed in the delivery contract as well as the delivery conditions of the manufacturer apply.

## 1.5 Copyright



### NOTES!

Content information, text, drawings, graphics, and other representations are protected by copyright and are subject to commercial property rights.

It is strictly forbidden to make copies of any kind or by any means for any purpose other than in conjunction with using the device without the prior written agreement of the manufacturer. Any copyright infringements will be prosecuted.

## 1.6 Guarantee terms

The guarantee terms are provided in the manufacturer's terms and conditions.

## 1.7 Customer service

For technical information personnel is available that can be contacted by telephone, fax or email. See manufacturer's address on page 2.

# 2 Safety



### DANGER!

This section provides an overview of all the important safety aspects that ensure protection of personnel, as well as safe and trouble-free device operation.

If these safety instructions are not complied with significant hazard can occur.

## 2.1 Responsibility of the owner

The device is used in commercial applications. Consequently the owner of the device is subject to the legal occupational safety obligations and subject to the safety, accident prevention and environmental protection regulations that are applicable for the device's area of implementation.

## 2.2 Personnel

Installation and commissioning as well as disassembly routines must be carried out by skilled technical staff only.

## 2.3 Intended use

The incremental encoder FG INOX has been designed and constructed exclusively for the intended use described here.

The unit is used for measurement of rotations, for instance of electrical and mechanical drives and shafts. The incremental encoders FG INOX with a housing made of V4A stainless steel has been specially developed for speed measurements in conditions exposed to aggressive media.

In combination with their extremely robust construction they are ideally suitable for applications exposed to extremely high levels of salt water (e.g., offshore) as well as acids and alkalis (e.g., chemical industry), where they offer a very high level of corrosion resistance.

The encoder housing and all external attachments are made of V4A stainless steel, the seals of Viton and the nameplate of polyester. Before use in corrosive atmospheres, it is recommended to test the corrosion resistance.

Claims of any type due to damage arising from non-intended use are excluded; the owner bears sole responsibility for non-intended use.

### For UL and CSA:

For the use in NFPA 79 applications only.

## 2.4 Improper use

	<p><b>Warning:</b> This device is not intended for use in residential areas and cannot ensure adequate protection of radio reception in such environments.</p>
---	--

Do not use the device in potentially explosive areas.

The device must not be subjected to mechanical loads in addition to its own weight and unavoidable vibration and shock loads that arise during normal operations.

Examples for non-permitted mechanical loads (incomplete list):

- Fastening transport or lifting tackle to the device, for example a crane hook to lift a motor.
- Fastening packaging components to the device, for example ratchet straps, tarpaulins etc.
- Using the device as a step, for example by people to climb onto a motor.

## 2.5 Personal protective equipment

Wear personal protective equipment such as safety shoes and safety clothing to minimise risks to health and safety when carrying out work such as installation, disassembly or commissioning. Adhere to all applicable statutory regulations as well as the rules and standards determined by the owner.

## 2.6 Special dangers

Residual risks that have been determined based on a risk assessment are cited below.

### 2.6.1 Electrical current



**DANGER!**

**Life-threatening danger due to electrical shock!**

There is an imminent life-threatening hazard if live parts are touched. Damage to insulation or to specific components can pose a life-threatening hazard.

**Therefore:**

Immediately switch off the device and have it repaired if there is damage to the insulation of the power supply.

De-energize the electrical equipment and ensure that all components are connected for all tasks on the electrical equipment.

Keep moisture away from live parts. Moisture can cause short circuits.

### 2.6.2 Rotating shafts / Hot surfaces



**WARNING!**

**Danger of injury due to rotating shafts and hot surfaces!**

Touching rotating shafts can cause serious injuries.

**Therefore:**

Do not reach into moving parts/shafts or handle moving parts/shafts during operation. Close to protect from injury all access openings in flanges with the corresponding plug screw, and provided you exposed rotating components with protective covers.

Do not open covers during operation. Prior to opening the covers ensure that all parts have come to a standstill.

The encoder can become hot during prolonged use.

In case of contact risk of burns is existing.

### 2.6.3 Safeguarding against restart



**DANGER!**

**Life-threatening danger if restarted without authorization!**

When correcting faults there is danger of the power supply being switched on without authorization.

This poses a life-threatening hazard for persons in the danger zone.

**Therefore:**

Prior to starting work, switch off the system and safeguard it from being switched on again.



## 3 Technical Data

### 3.1 Type plate

The figure below shows an example of a type plate:

Without option S or fiber optics.



The type plate and UKCA label are located on the side of the housing.

Type plate information:

Englisch	Deutsch
Manufacturer, address	Hersteller, Anschrift
Type:Incremental Encoder, Year of manufacture	Typ: Inkrementaler Drehgeber, Baujahr
CE mark	CE-Kennzeichnung
Serial number (S/N)	Seriennummer (S/N)
Pulse rate	Impulszahl
Degree of protection	Schutzart
Supply voltage	Versorgungsspannung
Outputs	Ausgänge
Certification UL	Zertifizierung UL
QR-code	QR-Code

### 3.2 Electrical and mechanical data

Pulse rates	1 ... 2048 (preset selectable)			
<b>Connection data</b>				
Supply voltage	12 V ... 30 VDC For UL and CSA Class 2 supplied			
No load-current	≤ 100 mA			
Connection	screw-type terminal Type Phoenix SPTAF 1 (0,25 mm <sup>2</sup> ... 0,75 mm <sup>2</sup> )			
Connection (Option fiber optic)	St-fiber optic plug			
Outputs	Current limited, short-circuit proof push-pull line driver.			
Pulse height (HTL)	approx. as supply voltage			
Output current per output	150 mA peak			
Duty cycle	1 : 1 ± 5 %			
Square wave displacement 0°, 90°	90° ± 5 %			
Max. frequency	200 kHz			
Start-up time	< 100 ms			
Encoder temperature range	-25°C ... + 85°C		For UL/CSA max. +60°C	
Degree of protection acc.DIN EN 60529	Sealing	Mech. permissible speed	Rotor moment of inertia	Breakaway torque
IP66	with radial shaft seal	≤ 6000 min <sup>-1</sup>	approx. 315 gcm <sup>2</sup>	approx. 3,5 – 4,0 Ncm
(UL und CSA Type 1)				
Vibration resistance		DIN EN 60068-2-6 / IEC 68-2-6 (10...2000 Hz)		10 g (=100 m/s <sup>2</sup> )
Shock resistance		DIN EN 60068-2-27 / IEC 68-2-27 (6 ms)		100 g (=1000 m/s <sup>2</sup> )
Weight		approx. 3,5 kg		
Max. encoder shaft load		F <sub>a, max.</sub> (axial) = 100 N F <sub>r, max.</sub> (radial) = 120 N		
Shaft dimensions		11j6 x 30 mm		

The FG INOX is categorised in Group 1 and Class A in accordance with EN 55011 and is only intended for use in an industrial environment.

### 3.3 Signal outputs

Signal outputs			
Basic channel 0° (A) and pulse channel 90° (B) Reference pulse (N) one square-wave pulse per revolution, Each with inverted signals	0°		Incr. Output 0°
	$\overline{0^\circ}$		Incr. Output 0° Inverse
	90°		Incr. Output 90°
	$\overline{90^\circ}$		Incr. Output 90° Inverse
	N		Reference
	$\overline{N}$		Reference Inverse

In case of an error, the signal outputs are switched to high impedance.

### 3.4 Operating states

There are 2 LEDs in the terminal box that indicate the operating status of the unit. Option S has an additional LED.

Operating status	LED	
	Status (green)	Error (red)
De-energised	OFF	OFF
Ready for operation	ON	OFF
Error	ON / OFF	ON

In case of an error, please contact Hübner Service (see page 2)!

## 4 Overview additional options

### 4.1 Option S (overspeed switch)

The incremental encoder FG INOX with option S has an insulated switching output. The switching function is realized with a semiconductor, the switching speed is set in our factory (switching hysteresis 10%).

If the set switching speed is exceeded, the switch opens.

It is recommended to save the switch circuit against an overcurrent with a fuse (0,5A).

Specification	Value
Deviation from switch:	Accuracy of measurement: 2% Switching time $T_{sw}$ : <3ms
Switch data	0...30V DC/max 500mA Max. voltage drop at closed switch: 0,7V

### 4.2 Option LWL (signal transmission using fiber optics)

The signals 0°, 90° and marker pulse from the incremental encoder will be encoded and transmitted via fiber optics cable. Fiber optic cable types 50/125 µm or 62,5/125 µm are available.

### 4.3 Type code

	FG	INOX	AK	1024	G	90G	NG	S
<b>Incremental encoder</b>								
<b>Housing of V4A stainless steel</b>								
<b>Connections</b> AK: Terminal box AL: Terminal box with connector for ST-compatible fiber optic plug								
<b>Pulses per rotation</b> 1 ... 2048 (preset selectable)								
<b>Basic version</b> Basic channel 0° (A) Pulse channel 90° (B) Each with inverted signals (not for LWL see chapter 4.2)								
NG: Reference pulse with inverted signal								
S: Option S								

## 5 Transport, packaging and storage

### 5.1 Safety instructions for transport



**CAUTION!**

**Material damage caused by improper transport!**

Observe the symbols and information on the packaging:

- Do not throw - risk of breakage
- Keep dry
- Do not expose to heat above 40 °C or direct sunlight.

### 5.2 Incoming goods inspection

Check delivery immediately upon receipt for completeness and possible transport damage.

Inform the forwarder directly on receipt of the goods about existing transport damages (prepare pictures for evidence).

### 5.3 Packaging / disposal

The packaging is not taken back and must be disposed of in accordance with the respective statutory regulations and local guidelines.

### 5.4 Storage of packages (devices)



**Keep dry**

Keep packages dry and free from dust; protect from moisture.

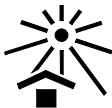

**Protect against heat**

Protect packages from heat above 40 °C and direct sunlight.

If you intend to store the device for a longer period of time (> 6 months) we recommend you use protective packaging (with desiccant).



**NOTES!**

Turn the shaft of the device every 6 month to prevent the bearing grease solidifying!

## 6 Mounting and commissioning

### 6.1 Safety instructions



**NOTES!**

Observe the safety instructions contained in **Chapter 2** when installing or working on the device!

**Personnel**

Installation and commissioning must be carried out by skilled technical staff only.

### 6.2 Technical information



**NOTES!**

Do not use a hammer or similar tool when installing the device due to the risk of damage occurring to the bearings or coupling!

**Ambient temperature**

The max. permissible ambient temperature depends on the speed and degree of protection of the device, the signal frequency, the length of the signal cable and the place of installation (please refer to Chapter 3.2).

**Degree of protection**

To fulfil degree of protection requirements the diameter of the connection cable must correspond to that of the cable gland (please refer to Chapter 12 dimension drawings)!

**Deep groove ball bearings**

FG INOX incremental encoders are fitted with maintenance-free, greased "for-life" deep groove bearings. Bearings must be changed by the manufacturer only. Opening the encoder renders the guarantee null and void.

**Screw retention**

We recommend using Loctite® 243 threadlocker (medium strength) on all fastening screws to prevent loosening.

### 6.3 Required tools

- Open-end spanner:                      wrench size 10 (e.g. DIN 894)
- Face spanner
- Flat-blade screwdrivers:
- Assembly grease
- Loctite® 243                              (medium strength threadlocker)

## 6.4 Mounting preparations

1. Ensure all accessories are available (please refer to Chapter 12 Dimension drawings).



**NOTES!**

Earth cable is not included in the range of supply.

2. Preparing the place of attachment: Clean the (motor) shaft, centering, bolting surfaces and fastening threads; check for damage. Repair any damage!

## 6.5 Mounting of incremental encoder



**NOTES!**

For a mounting example please refer to dimension drawing HM 20 M 114476 (Chapter 12).

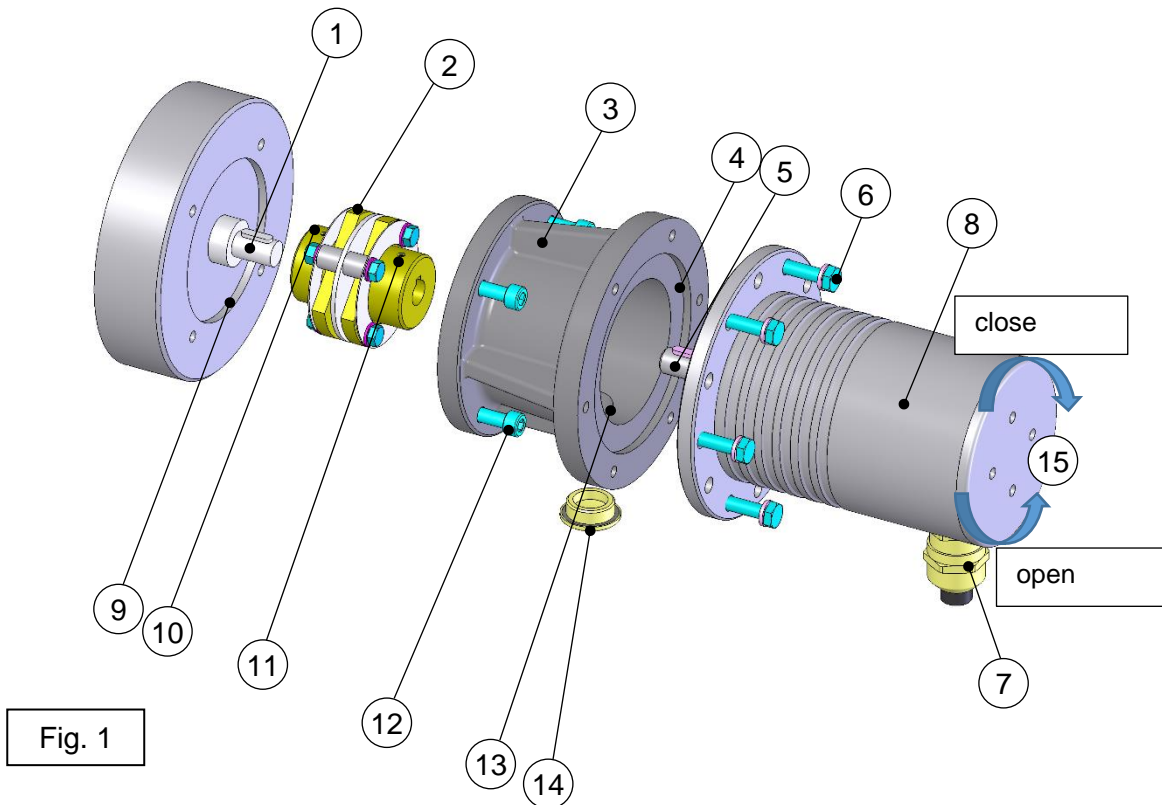

1. Lightly grease the (motor) shaft (1) and centering (9).
2. Fit coupling (2) onto (motor) shaft.



**NOTES!**

You must be able to mount the coupling without force. Ream out the bores of used couplings, if necessary!

We recommend our zero-backlash, torsion-resistant coupling HK5 to attach the incremental encoder. Please refer to the catalogue Torsion Resistant Couplings for Encoders.

3. Secure the coupling hub on the (motor) shaft with a grub screw or cheese head screw (10) (depending on the coupling type).
4. Fasten the intermediate flange (3) to the motor using the fastening screws (12).



**NOTES!**

If possible, fit the intermediate flange in a manner that ensures the screwed sealing plug (14) points downwards!

5. Lightly grease the encoder shaft (5) and centering (4).
6. Fit the encoder (8) into both the centering (4) and coupling hub at the same time.



**NOTES!**

You must be able to mount the coupling without force. Ream out the bores of used couplings, if necessary!



**NOTES!**

If possible, fit the device in a manner that ensures the cable gland (7) points downwards

7. Secure the encoder with 4-6 screws (6) evenly distributed around the circumference of the flange.
8. Remove the sealing plug (14) from the access bore (13) to the coupling.
9. Secure the coupling hub on the encoder shaft with a grub screw or cheese head screw (11) (depending on the coupling type).



**NOTES!**

To carry out this task, it may be necessary to turn the (motor) shaft to the correct position.

10. Replace the sealing plug (14) to seal the access bore to the coupling.



## 6.6 Permissible mounting deviations



### NOTES!

Angle misalignment and parallel displacement between the (motor) shaft and the encoder shaft are mounting errors and should be kept as small as possible.

### Mounting errors

- Cause radial forces to act on the encoder shaft.
- Reduce the service life of the bearings and the coupling.
- Degrade the quality of the signals (harmonic content).

Mounting tolerances for our zero-backlash, torsion-resistant couplings HK5 and HKD5:

Coupling	Axial offset	Angular error	Parallel offset
HK 5	± 1 mm	0.5°	-
HKD 5	± 1.5 mm	0.5°	0.5 mm

### 6.7 Electrical connection and start up



**NOTES!**

You must observe applicable EMC guidelines when routing cables!



**NOTES for UL and CSA!**

Do only use copper cables. Suitable, listed (ZJCZ/7) flexible cord type minimum S or SJ shall be installed in field.

#### 6.7.1 Preparing cables

1. Strip cable insulation. The cable for the signal and supply line is shielded.
2. Crimp wire-end ferrules.

#### 6.7.2 Electrical connection

1. Open the terminal box cover (15, Fig.1) with a special key by turning it counterclockwise. The terminal box cover has a right-hand thread.



**CAUTION!**

Do not allow moisture to enter the terminal box when the cover is open!

2. Remove the cap of the cable gland (7, Fig. 1).
3. Feed the cable into the terminal box through the cable gland.



**NOTES!**

The signal cable shielding can be connected directly to the housing via the EMC cable gland. To achieve an effective shielding the cable shield must also be connected in the electrical cabinet.

4. Tighten the cable gland and blanking plugs using a spanner.



**NOTES!**

Prior to delivery cable glands and blanking plugs are tightened finger tight only. To ensure that the terminal box is reliably sealed tighten all cable glands and blanking plugs before starting up for the first time.

5. Use a spanner to tighten the cable gland until the cable is securely clamped and properly sealed.



**NOTES!**

Prevent lateral pulling forces acting on the cable and plugs so as not to impair the degree of protection of the cable gland.

6. Connect the supply voltage, the signal cable and possibly option S (please refer to the connection diagrams, Chapter 12).



**CAUTION!**

Do not apply supply voltage to the signal outputs, as this will destroy the device!

7. Close the terminal box cover.



**NOTES!**

Before closing the terminal box cover check and if necessary clean both seal surfaces and the gasket.

## 7 Dismantling

### 7.1 Safety instructions

#### Personnel

Dismantling must be carried out by skilled technical staff only.



#### WARNING!

Observe the safety instructions contained in **Chapter 2** when inspecting or working on the device!



#### NOTES!

Do not use a hammer or similar tool when installing the device due to the risk of damage occurring to the bearings or coupling!

### 7.2 Dismantling the encoder

Remove all electrical cables from the device before dismantling. To dismantling the encoder follow the instructions given in Chapters 6.5 in the reverse order.

## 8 Faults

### 8.1 Faults table

Faults	Possible cause	Remedy
Switch does not close (only by option S)	No supply voltage <u>Control</u> : LED in the terminal box does not shine	Check connection cable and supply voltage
	<u>Error LED does not shine</u> : Rotation speed above the switching speed	Adjust the suitable rotation speed
	<u>Error LED is shining</u> : Evaluation of rotation speed is faulty.	Disconnect power supply and switch on again
Moisture in the terminal box	Soiled terminal box gasket or seal surfaces	Clean terminal box gasket and seal surfaces
	Damaged terminal box gasket	Replace terminal box gasket
	Cable gland/blanking plug not tightened	Tighten cable gland/blanking plug
	Unsuitable cable for cable gland	Use suitable cable and cable glands
No output signals	Supply voltage not connected	Connect supply voltage
	Connection cable reversed	Wire correctly
Output signals subject to interference	Unsuitable cable	Use data cable with conductors arranged as twisted pairs and common shield
	Cable shield not connected	Connect cable shield at both ends
	Cable routing not EMC compliant	Observe applicable EMC guidelines when routing cables
Signal interruptions	Signal end stage overloaded	Check pin assignment; observe connection diagram
		Do not assign unused outputs
	Outputs short-circuited	Do not connect outputs with supply voltage or GND
Contact Hübner-Service (page 2) if none of the remedies listed above provides a solution)!		

## 9 Inspections

### 9.1 Safety instructions



**NOTES/PERSONNEL!**

Skilled technical staff only are permitted to inspect the device and its installation. Observe the safety instructions contained in **Chapter 2** when inspecting or working on the device!

### 9.2 Maintenance information

The device is maintenance-free. However, to guarantee optimum fault-free operations we recommend that you carry out the following inspections.

### 9.3 Inspection schedule

Interval	Inspections
Yearly	Inspect the coupling for damage and ensure it is free of play
	Ensure the fastening screws are properly tightened
	Check cable connections and connection terminals for tightness
Following approx. 16.000...20.000 hours of operation / higher levels of continuous load	Check deep groove ball bearings are running smoothly and listen for running noises

For FG INOX with option S, no extra inspection is required.

## 10 Disposal

### 10.1 Disposal procedure

The manufacturer is not obliged to take back the device.

The device must be treated as special electronic waste and disposed of in accordance with country-specific laws.

For information on environmentally sound disposal please contact your local authority or a specialist disposal company.

## 11 Replacement parts

The replacement parts listed below can be obtained via the service address on page 2.

Replacement parts	Comment
EMC cable gland	M 20 x 1.5, cable Ø 9...13 mm
Terminal box cover	Including O-ring
Screw plug	For closing the access to the coupling in the intermediate flange

12 Dimension drawings

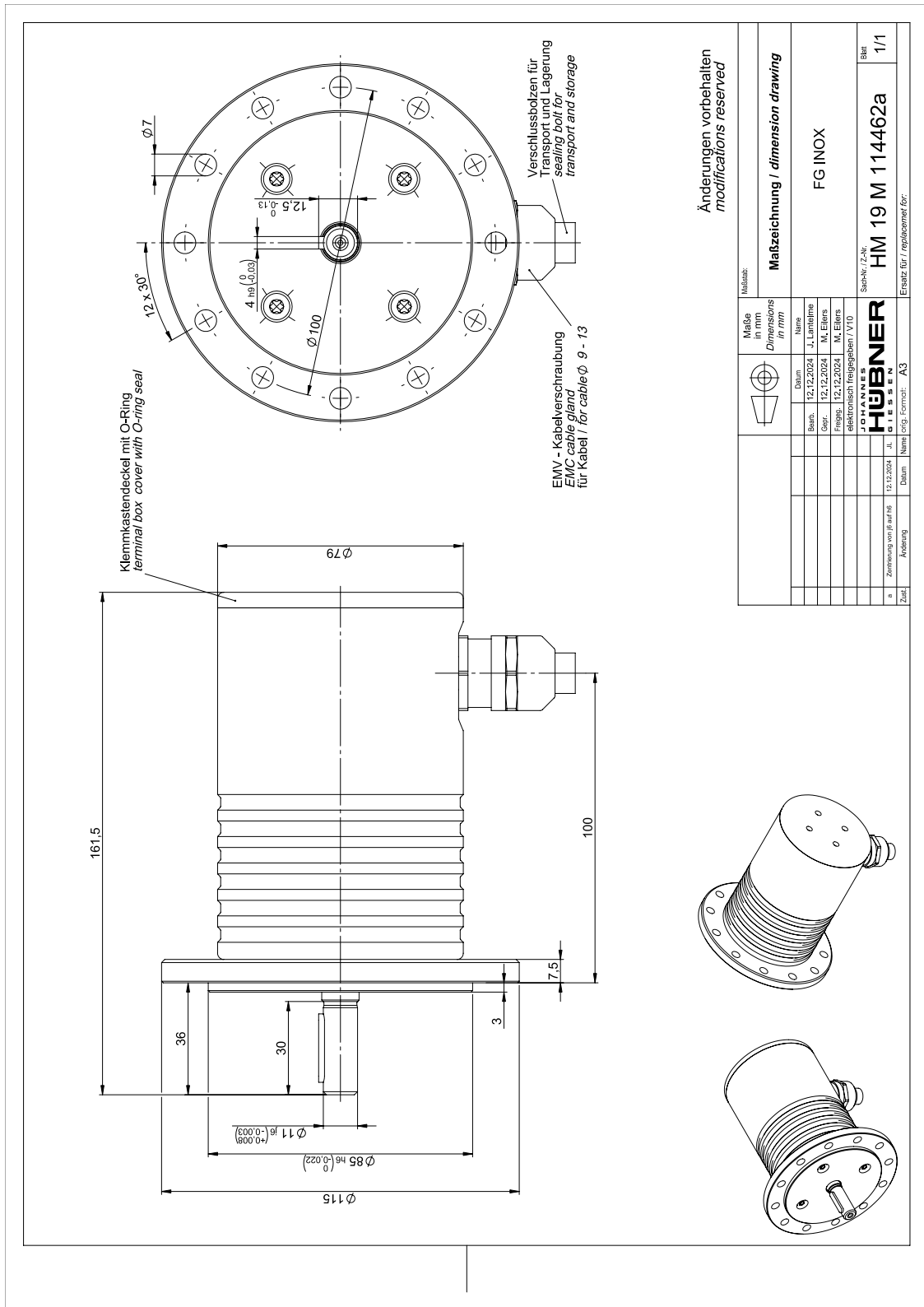

**6x Sechskantschraube**  
hex head screw  
ISO 4017 - M6 x 2 - A4-70  
6x Scheibe / washer  
ISO 7089 - 6 - 200 HV-A4  
**Anzugsmoment**  
tightening torque  
**T = 6,5 Nm**

**4 x Zylinderschraube**  
hex cap screw  
ISO 4762 - M6 x 18 - A4-70  
**Anzugsmoment**  
tightening torque  
**T = 6,5 Nm**

**Zwischenflansch / intermediate flange**  
ZS-114884

**Zugang zur Kupplung**  
access to coupling

**FG INOX**  
HM 19 M 114462

**125,5**  
**69**  
**52**  
**6**  
**5**

**Ø 100**  
**Ø 70 h7 (-0,03)**  
**Ø 11<sub>16</sub> (+0,008)**  
**M 6**  
**8**

**36**  
**33**  
**2**

**6x Sechskantschraube**  
hex head screw  
ISO 4017 - M6 x 2 - A4-70  
6x Scheibe / washer  
ISO 7089 - 6 - 200 HV-A4  
**Anzugsmoment**  
tightening torque  
**T = 6,5 Nm**

**6**  
**52**  
**22**  
**22**  
**54**  
**11**  
**29**  
**2**

**FG INOX**  
HM 19 M 114462

**80**

**54**  
**22**  
**22**  
**11**  
**29**  
**2**

**Kupplung / coupling:**

**Verdrehschleife Kupplung - nichtrostend**  
Torsion-resistant coupling - stainless steel  
HK 522 - 11/ d  
Montageanleitung / Mounting instruction : Nr. 54690

d <sup>GT</sup>	t	u
12	13,8	4
14	16,3	5
16	18,3	5
20	22,8	6
max. bis 22		

Andere Durchmesser siehe Kupplungskatalog!  
Other diameters see coupling catalog!

**Änderungen vorbehalten**  
modifications reserved

**Maßstab:**  
Maßzeichnung / dimension drawing

**FG INOX-Anbau Maßzeichnung**  
FG INOX mounting dimension drawing

**Sachz. / Z-Nr.**  
HIM 20 M114476

**Blatt:**  
1/1

**Ersetzt für / replaces for:**

Maße in mm / Dimensions in mm	Name	Datum	Beib.	Gepr.	Freigegeben
	M. Wiener	12.03.2020			
	M. Ellers	12.03.2020			
	M. Ellers	12.03.2020			
	elektronisch freigegeben / Vg				

**HUBNER**  
JOHANNES  
GIESSEN

**DRG**

**Änderung** **Datum** **Name (engl. Format)** **A3**

**Zust.**

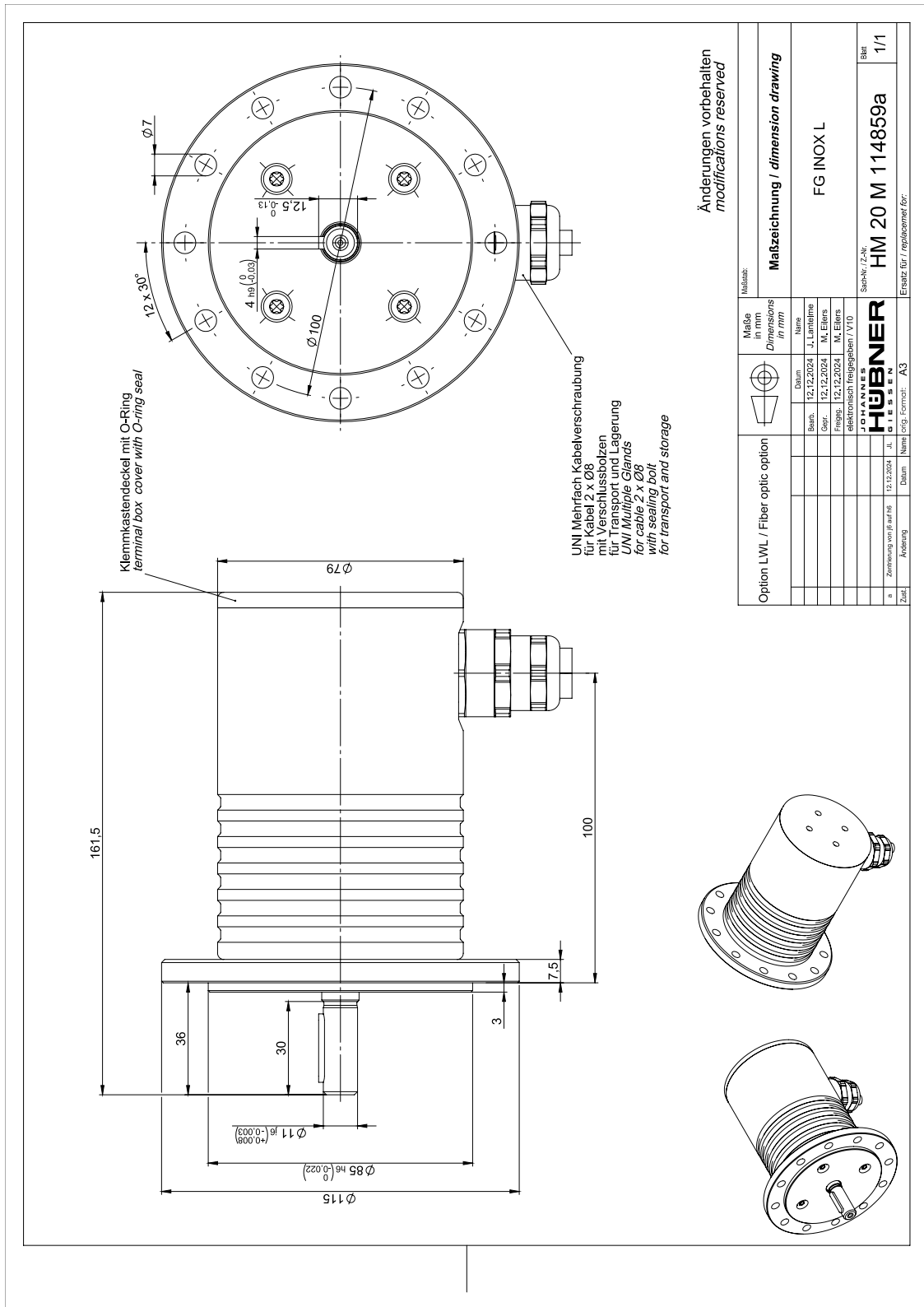

Änderungen vorbehalten  
modifications reserved

Maße in mm Dimensions in mm		Name	
Option LWL / Fiber optic option		Beitrag	12.12.2024
		Gepr.	12.12.2024
		Freigegeben	12.12.2024
		elektronisch freigegeben / V1.0	
		<b>JOHANNES HÜBNER GIESSEN</b>	
		Sach-Nr. / Z-Nr.: <b>HM 20 M 114859a</b>	
		Blatt: <b>1/1</b>	
		Ersatz für / replacement for:	
		Zust.: Änderung Datum Name Orig. Format: A3	

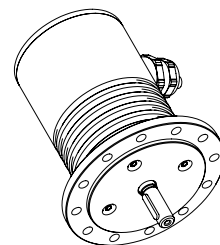
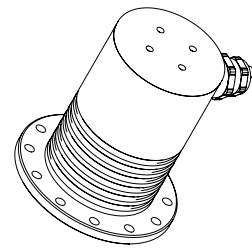



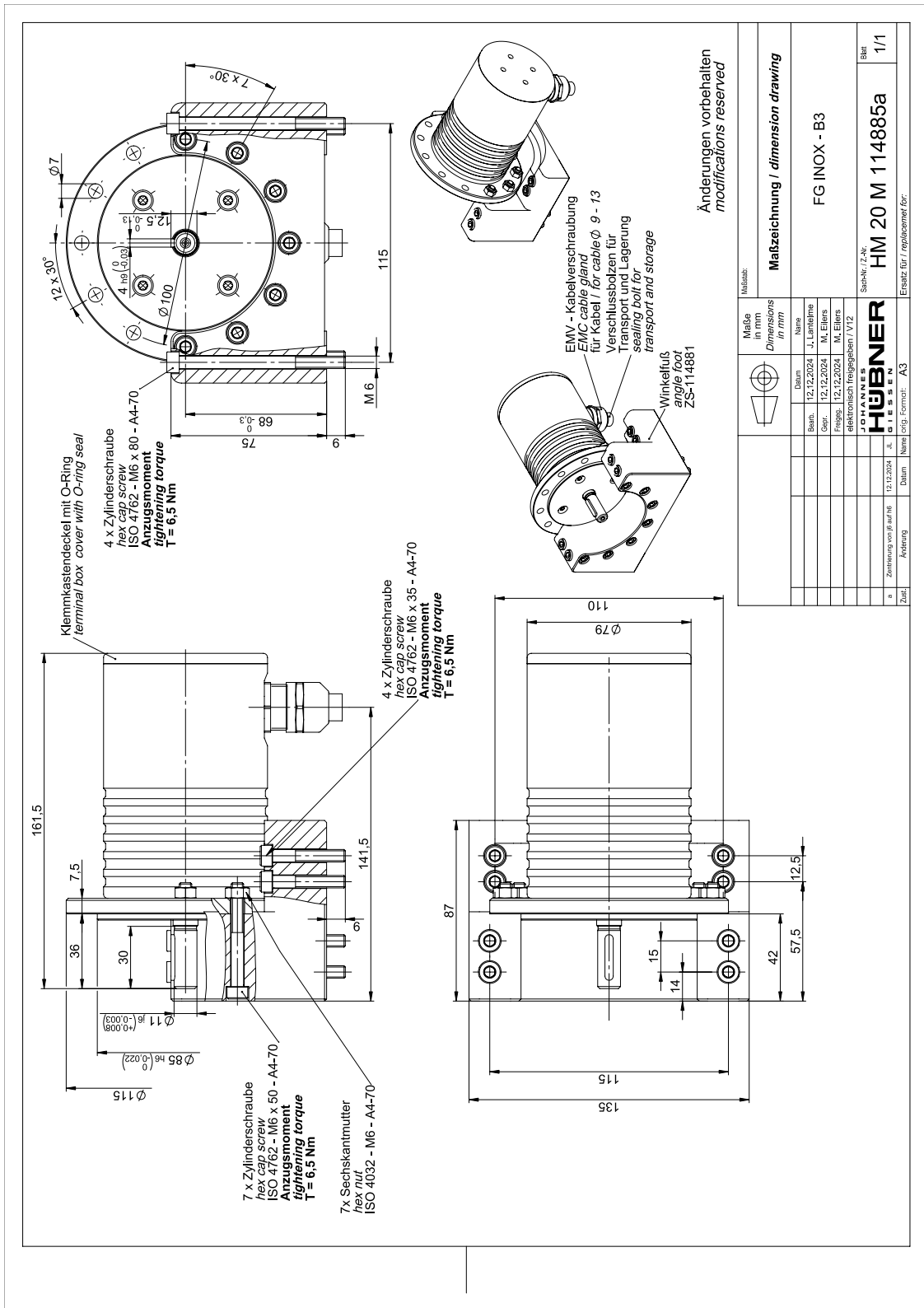

Maße in mm Dimensions in mm	
Name	FG INOX - B3
Datum	12.12.2024
Benr.	J. Lamelle
Genr.	M. Eilers
Freigeig.	12.12.2024
elektronisch freigegeben / V12	M. Eilers
<b>HUBNER</b> JOHANNES G I S S E N	
Blatt	1/1
Sach-Nr. / Z-Nr.: <b>HM 20 M 114885a</b> Ersatz für / replacement for:	

## 13 Connection diagrams

### 13.1 Terminal box



**NOTES!**

The connection diagrams are displayed in each terminal box cover!

PN230-400		
Connection diagram		
1	GND	0V
2	Supply voltage	+U
3	Incr. output 0°	
4	Incr. output 0° inv.	
5	Incr. output 90°	
6	Incr. output 90° inv.	
7	Reference pulse	
8	Reference pulse inv.	
9	Overspeed switch	
10	(Optional)	

Shielding: Connection between cable shield and housing via cable gland

PN230-401		
Connection diagram		
1	GND	0V
2	Supply voltage	+U
3	Fiber optic connection	FOC

Connection technology AK

Connection technology AL