



U-ONE[®]-SAFETY-LWL Universal encoder system Generation II

Installation Instructions Electronics

**Before mounting, starting installation and other
read the operating and assembly instructions!
Keep for future reference.**

Manufacturer

Johannes Hübner	Phone:	+49 641 7969 0
Fabrik elektrischer Maschinen GmbH	Fax:	+49 641 73645
Siemensstr. 7	Website:	www.huebner-giessen.com
35394 Giessen / Germany	E-Mail:	info@huebner-giessen.com

These instructions and the enclosed declaration of conformity can also be accessed via our Service Point. For this purpose, the QR code on the type plate of the corresponding device must be scanned.

Trademark

Brand and product names are trademarks or registered trademarks of their respective owners. Protected trademarks [™] or [®] are not always designated as such in this manual. However, this does not mean that they may be used freely.

Copyright protection

This manual, including the figures it contains, are copyright protected. Third party usage of this manual in deviation from copyright regulations is prohibited. The reproduction, translation or electronic and photographic archiving and amendment of this manual shall require written approval by the manufacturer. Violations will result in claims for damages.

Copyright © Johannes Hübner Fabrik elektrischer Maschinen GmbH

Reservation of rights

This manual has been prepared carefully. However, it may contain formal errors or errors in content.

All rights reserved.

Table of contents

1 Using the installation instructions	4
2 Planning an application.....	4
2.1 Operating conditions	4
2.2 Electromagnetic compatibility.....	4
2.3 Direct current distribution	5
2.3.1 Separate power supply unit.....	5
2.3.2 Star-shaped configuration	5
2.3.3 Simplified distribution using UO-ETM-2 modules (optional).....	6
2.3.4 Remote power supply unit for basic unit at a great distance.....	7
2.4 Requirements for the wiring	7
2.4.1 Supply cable for basic unit.....	7
2.4.2 Incremental output and current output.....	7
2.4.3 Signal and switching cables outside of control cabinets	8
2.4.4 Grounding strap for the basic unit.....	8
2.4.5 Grounding point for basic unit.....	9
2.4.6 Fiber optic cable.....	9
2.4.7 PROFINET and PROFIBUS cables.....	9
2.4.8 USB cable.....	9
2.5 Organization of the control cabinet.....	9
2.5.1 Distribution of the installation space	9
2.5.2 Connection terminals for supporting cable shields.....	10
3 Professional execution of the installation.....	10
3.1 Connecting the basic unit.....	10
3.1.1 Connecting the power supply	10
3.1.2 Cable length.....	11
3.1.3 Shield contacting for EMC cable gland with cone	11
3.1.4 Shield contacting for EMC cable gland with clamp	11
3.1.5 Connecting the fiber optic cable	12
3.1.6 Grounding	12
3.1.7 Cover cap for terminal box	12
3.2 Control cabinet installation	13
3.2.1 Order of modules	13
3.2.2 Mounting on the top-hat rail.....	14
3.2.3 Dismantling	15
3.2.4 Vibration protection	15
3.2.5 Connecting the cable shields.....	16
4 Quality assurance.....	16

1 Using the installation instructions

These instructions provide practical information on planning and installing a U-ONE® (SAFETY) LWL application. It must be read carefully and observed before starting any work.

The Operating and Assembly Instructions for the U-ONE basic unit and the U-ONE function modules must also be observed.

2 Planning an application

2.1 Operating conditions

The U-ONE system is used to safely monitor and control operating states. Compliance with the permissible operating ranges is important for trouble-free operation. This applies to mechanical installation tolerances and ambient conditions. Media, operating temperature, vibration, shock, power supply and electromagnetic emissions from external systems must comply with the specified limit values in accordance with the operating instructions. Otherwise, internal diagnostics will switch the system to a safe state.

2.2 Electromagnetic compatibility

In environments with high drive power, external systems can generate high electromagnetic emissions. Adverse effects on U-ONE operation can be avoided by observing the following guidelines:

- Uninterrupted, low-resistance machine grounding must be ensured across all parts of a plant. Ensure that the connections have good electrical contact. Poor conductivity can be caused, for example, by paint, lubricants, corrosion or similar. In practice, large cable cross-sections are required for low-resistance machine grounding.
- Generous mounting distances must be maintained from actuators with a high energy density, such as contactors, inverters, motors, solenoid valves and brakes.
- Shielding of cables must be carried out professionally, for example between the inverter and motor. Please observe the manufacturer's specifications.
- Inductances of relays, contactors, solenoid valves or brakes should be wired with suppressors. To prevent conducted interference coupling, this is necessary for relays or contactors that are connected directly to the inputs or outputs (IO) of the U-ONE function modules. To prevent interference coupling via the air path, this also applies to all inductances in the near field of the U-ONE installation, including connected peripherals. Suppressors must be connected directly to the coil: RC elements or varistors for operation with alternating current (AC) and freewheeling diodes or varistors for operation with direct current (DC), whereby freewheeling diodes are preferable.
- The U-ONE system is operated with low voltage of up to 30 V. To avoid interference coupling via the air path, it is important to plan cable routes with sufficient distance to power lines in accordance with the following diagram. This generally applicable diagram is to be used for all connections **inside** and **outside** control cabinets.

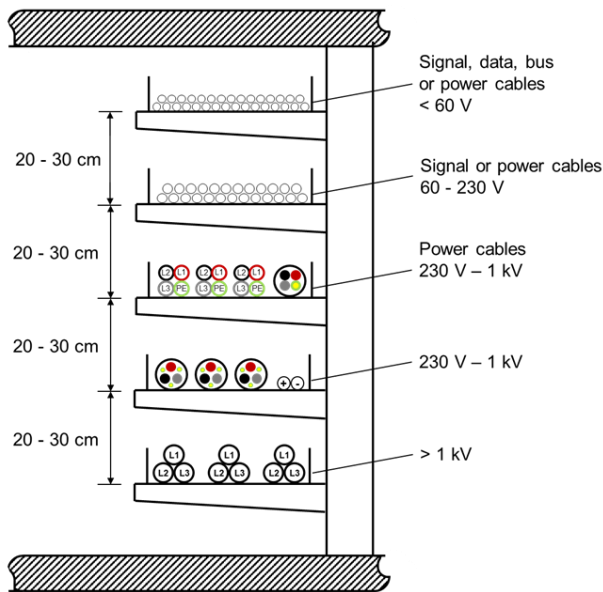

Figure 1: Scheme for planning cable routes

2.3 Direct current distribution

In a typical application, one or more U-ONE systems are supplied from one power supply unit. By connecting several basic units and several U-ONE module groups, including connected peripherals, the DC distribution network - inside and outside control cabinets - can cover considerable cable lengths. This network increases if the same power supply unit feeds other external systems. To ensure trouble-free DC distribution, it is recommended that the following guidelines are observed.

2.3.1 Separate power supply unit

For decoupling from external systems, the use of a separate power supply unit is recommended for the U-ONE function groups including their peripherals. A suitable power supply unit of the type "MEAN WELL NDR-120-24" is available as an accessory from Johannes Hübner Fabrik elektrischer Maschinen GmbH.

2.3.2 Star-shaped configuration

To minimize interference, each U-ONE function group should be connected to the power supply unit in a star-shaped configuration and with symmetrical routing of the go-and-return line (as a twisted pair or as a cable).

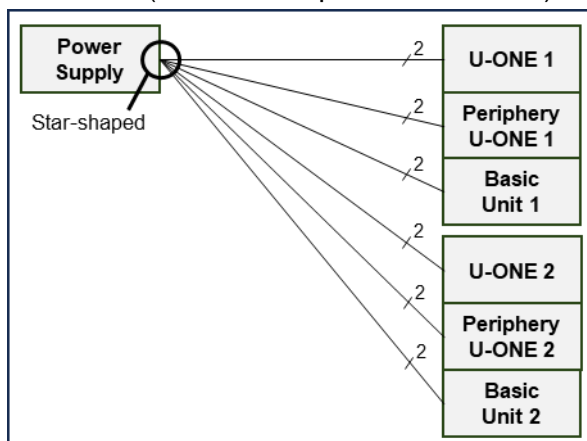

Figure 2: Principle of direct current distribution for more than one U-ONE system

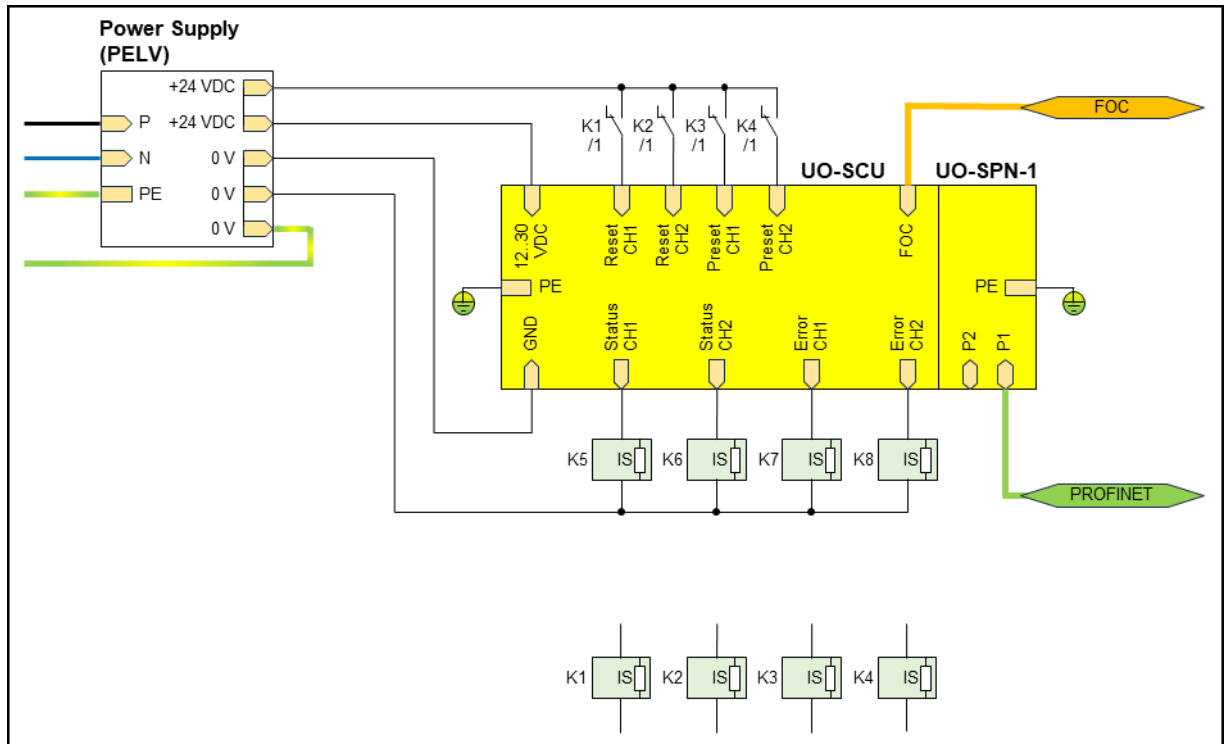

Figure 3: Application example for relays and contacts in the U-ONE periphery.
IS = Interference suppressor (interference suppressor)

2.3.3 Simplified distribution using UO-ETM-2 modules (optional)

The UO-ETM-2 is an additional module for simplifying control cabinet wiring. It contains additional connection terminals for the basic unit and peripherals.

Additional filters are built into the supply branches to prevent interference coupled into one cable section from having an unattenuated effect on other cable sections of the DC distribution.

Using the UO-ETM-2 is particularly advantageous for installations with several U-ONE systems and for environments with particularly high electromagnetic interference.

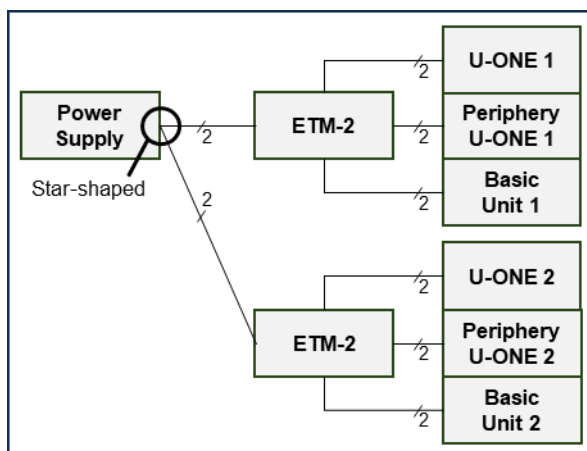

Figure 4: Principle of direct current distribution with optional UO-ETM-2 module

2.3.4 Remote power supply unit for basic unit at a great distance

Typically, one power supply unit is provided for applications to supply all U-ONE function groups including the basic units. For cable runs of more than 30 meters in length (guide value) or for installation routes parallel to power cables with high electromagnetic emissions, a remote power supply unit is recommended, which is arranged near a basic unit.

2.4 Requirements for the wiring

2.4.1 Supply cable for basic unit

A shielded connection cable in accordance with the following specification must be used for the electrical connection of the USL(H) 42 basic unit:

Outer diameter of the cable:	7.0-10.5 mm
Wire cross-section:	0.75 mm ²
Shield:	Braid of tinned copper wires, coverage 85% or more

The following cable properties must be selected according to the application:

- UV resistance for outdoor use
- Media resistance
- Mobility for travel paths (e.g. for drag chains)
- Temperature range

For typical outdoor applications, for example, the LAPP ÖLFLEX CLASSIC 110 CY BK 2X0.75 cable can be used, which is available as an accessory from Johannes Hübner Fabrik elektrischer Maschinen GmbH. It is suitable for fixed installations without cable movement. Temperature range is -40°C to +80°C. It is UV and oil resistant.

2.4.2 Incremental output and current output

Shielded cables must be used for the incremental output and the current output of the UO-SCU both inside and outside a control cabinet in accordance with the following specification:

Wire cross-section:	0.25 mm ²
Cable construction:	Pair stranding 2x2
Shield:	Braid of tinned copper wires, coverage 85% or more

The following cable properties must be selected according to the application:

- UV resistance for outdoor use
- Media resistance
- Mobility for travel paths (e.g. for drag chains)
- Temperature range

For typical indoor applications, for example, the LAPP UNITRONIC LiYCY (TP) 2x2x0.25 cable can be used. It is suitable for fixed installations without cable movement. Temperature range -40°C to +80°C. It is not oil-resistant and not UV-resistant.

2.4.3 Signal and switching cables outside of control cabinets

For signal and switching cables of the U-ONE installation, which are laid between or outside control cabinets, shielded cables must also be used in accordance with the following specification:

Wire cross-section:	0.25 mm ²
Shield:	Braid of tinned copper wires, coverage 85% or more

The following cable properties must be selected according to the application:

- Number of wires as required
- UV resistance for outdoor use
- Media resistance
- Mobility for travel paths (e.g. for drag chains)
- Temperature range

For typical indoor applications with 4 signal lines, for example, the LAPP UNITRONIC LiYCY 4x0.25 cable can be used. It is suitable for fixed installations without cable movement. Temperature range -40°C to +80°C. It is not oil-resistant and not UV-resistant.

2.4.4 Grounding strap for the basic unit

A flat grounding strap consisting of fine stranded wire with a minimum cross-section of 6 mm² must be used to ground the basic unit. Newer U-ONE basic units USL(H) 42 are supplied with a pre-assembled grounding strap. A suitable grounding strap is available as an accessory from Johannes Hübner Fabrik elektrischer Maschinen GmbH. The function of the grounding is shielding against high-frequency interference signals. A green/yellow marking is not required as this is not a protective grounding.



Figure 5: Permanently connected grounding strap on the USL 42 basic unit

2.4.5 Grounding point for basic unit

To ground the USL(H) 42 basic unit, the connected grounding strap must be permanently connected to a well-chosen, nearby grounding point, ideally on the main structure of the system. The grounding point must be bare metal, free of paint, non-conductive surface finishes, grease, oil and corrosion. The grounding point must be protected against long-term corrosion, for example by mounting it in a dry place. The required mounting material is supplied with the basic unit.

Ideally, suitable grounding points should be determined during the planning phase.

2.4.6 Fiber optic cable

Fiber optic cables with the following specifications are suitable:

- 50/125 µm or 62.5/125 µm
- ST connectors

For outdoor applications, industrial FO cables with protective sheathing must be used: Type LAPP HITRONIC® TORSION Multimode 50/125 µm or 62.5/125 µm or equivalent. We also recommend this type for indoor applications.

2.4.7 PROFINET and PROFIBUS cables

Original PROFINET or PROFIBUS cables with permanently connected and shielded plugs or sockets must be used, for example: SIEMENS 6XV1840-2Axxx (PROFINET) or 6XV1830-0Exxx (PROFIBUS).

2.4.8 USB cable

The U-ONE® (SAFETY) LWL system is configured via the USB port of the UO-SCU module.

Once the configuration is complete, the USB cable must be disconnected. A USB cable permanently attached to the UO-SCU module may cause electromagnetic interference to the U-ONE® (SAFETY) LWL system during operation.

2.5 Organization of the control cabinet

2.5.1 Distribution of the installation space

Short connections are generally useful for control cabinet cabling. The easiest way to achieve this is by grouping U-ONE function modules, power supply units and peripherals spatially, possibly also taking into account short connection routes to a PLC.

The diagram for planning cable routes (see Figure 1) must also be observed in the control cabinet, for example by defining the wiring route for low voltages away from higher voltage connections.

Sufficient distance must be maintained between the U-ONE function groups and systems with increased electromagnetic emissions, e.g. radio transmitters or components that are difficult to suppress.

2.5.2 Connection terminals for supporting cable shields

Shield connection clamps, which are also available as accessories from Johannes Hübner Fabrik elektrischer Maschinen GmbH, must be used to support the cable shielding in the control cabinet. Cable shields must always be connected at both cable ends.



Figure 6: Cable connection terminals for control cabinet mounting

3 Professional execution of the installation

3.1 Connecting the basic unit

3.1.1 Connecting the power supply

The terminal box of the basic unit has two openings for inserting cables. The following applies to the insert of the power supply: The shield of the cable must be correctly contacted with the EMC cable gland supplied.



Figure 7: Original EMC cable gland on the USL(H) 42 basic unit

The wires must be fitted with wire end ferrules before connection.

Two different types of cable gland are used.

3.1.2 Cable length

The cable shield should have a length of at least 5 mm so that the shield contact can be connected correctly. You should also ensure that the individual wires are long enough so that they can be laid correctly in the terminal box.

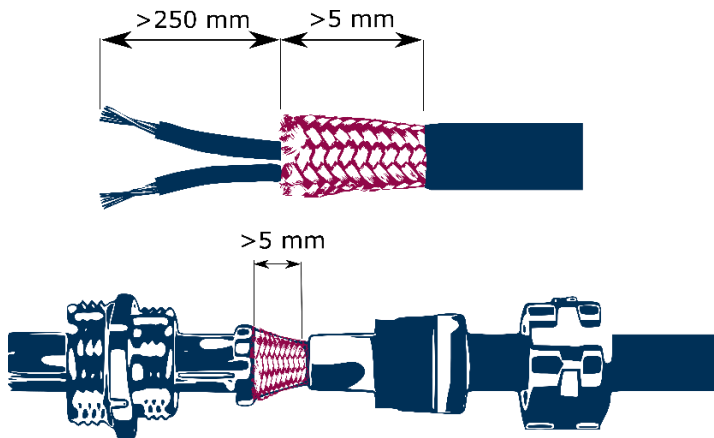

Figure 8: Cable length

3.1.3 Shield contacting for EMC cable gland with cone

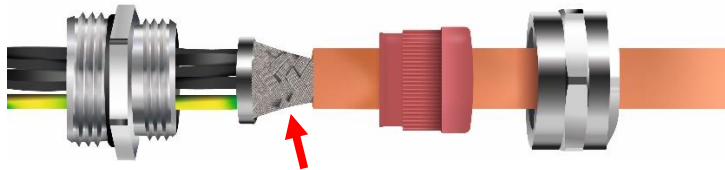

Figure 9: Cable gland with cone

The shield is placed on the cone. The insulation must be removed at this point. The shielding must remain intact in this area and must not be damaged.

3.1.4 Shield contacting for EMC cable gland with clamp

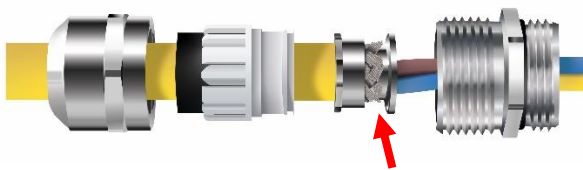

Figure 10: Cable gland with clamp

Clamp the end of the shield between the two clamping elements (pair of cones). Ensure good contact between the shield and clamping elements and a tight fit.

3.1.5 Connecting the fiber optic cable

The fiber optic cable is inserted into the terminal box of the basic unit via the second cable gland and is connected to a ST plug at the fiber optic output. Several slotted sealing inserts for different cable diameters are included with the basic unit for the FO cable gland. The outer sheath of the fiber optic cable must be firmly seated in the sealing insert of the cable gland.

In the terminal box, the fiber optic cable must be laid in a loop without an outer sheath and without kinks to avoid tensile forces.



Figure 11: Fiber optic cable and supply cable in the terminal box of the USL(H) 42 basic unit

3.1.6 Grounding

The grounding strap should be connected from the USL(H) 42 basic unit to the earthing point with the shortest possible length. The grounding strap may have to be shortened for this purpose. A cable lug included in the scope of delivery must be fitted to the end of the cable using a crimp.



Figure 12: Connecting the grounding strap to an earthing point

3.1.7 Cover cap for terminal box

The terminal box of newer U-ONE basic units USL(H) 42 contains a cover cap for increased protection against electromagnetic interference. For older basic units, this is available as an accessory to be ordered separately from Johannes Hübner Fabrik elektrischer Maschinen GmbH.

3.2 Control cabinet installation

3.2.1 Order of modules

The following points must be observed during installation:

- The UO-SCU or UO-ECU controller module must be installed on the left-hand side as the first module (marked in red).
- Communication modules (UO-EPB, UO-SPB, UO-SPN, UO-EPN) must be installed on the right-hand side as the last module (marked in blue).
- If a UO-ETM-2 module is used, it must be positioned on the far left.
- The order of the other modules can be freely selected.

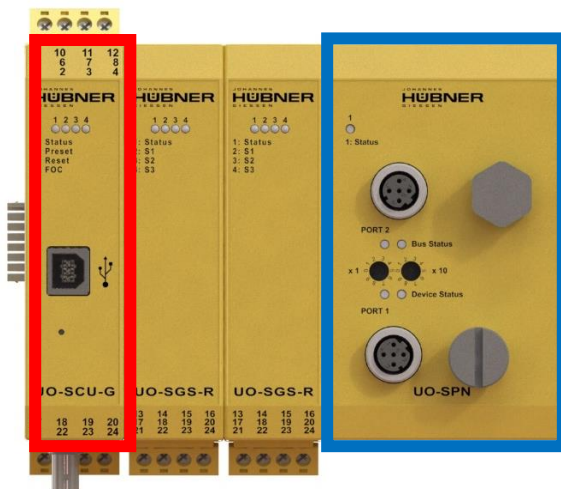

Figure 13: Installation order of the U-ONE modules
Red: Controller module. Blue: Communication module

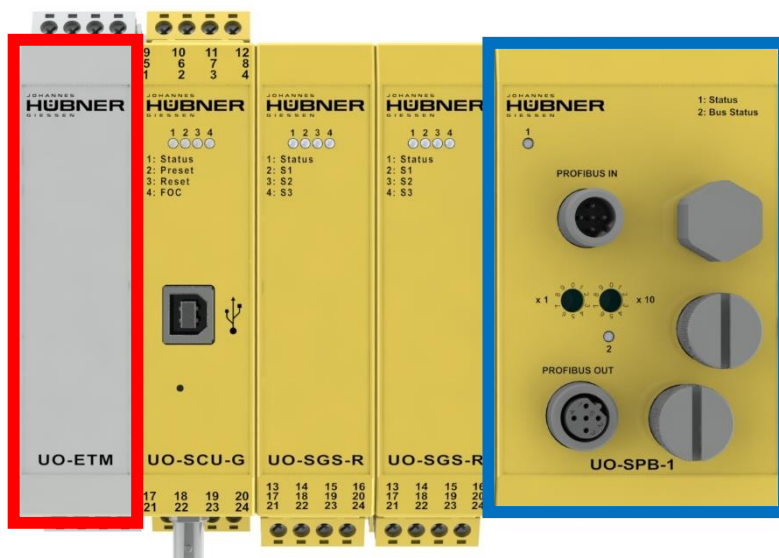
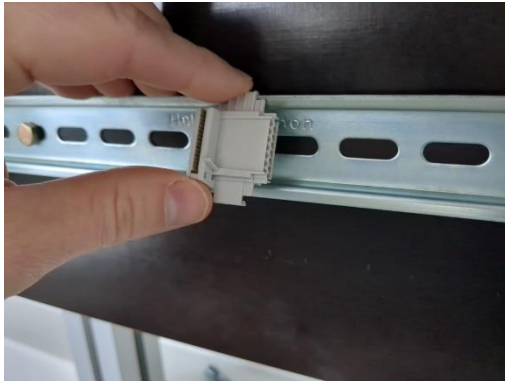

Figure 14: Installation order when using a UO-ETM-2 module
Red: UO-ETM-2 module. Blue: Communication module

3.2.2 Mounting on the top-hat rail

1. Mount the bus connector on the top-hat rail. To engage, ensure that the individual bus connectors are first hooked in on one side. The opposite side is then snapped in with pressure.

If the ends of the top-hat rail are freely accessible, connectors can also be inserted from the side.



2. Insert the bus connectors into each other at the side and connect them as a result.



3. Mount the modules individually. These are placed on the top-hat rail from above and then swung into place. Ensure that the modules snap into place.



4. Install end brackets if required (see chapter 3.2.4).

3.2.3 Dismantling

1. The cables on the terminal strips do not have to be disconnected individually, as the terminal strips can be removed together with the cables. Removal is made easier by using a screwdriver as a lever. This makes it easier to fit a replacement device.



2. First remove the individual modules. To release the fixing on the top-hat rail, the fuse must be pulled downwards. To do this, use a screwdriver, for example, from below.



3. The module can then be swung out.
4. The bus connectors can be pushed off the side of the top-hat rail. If this is not possible, a screwdriver can also be used to lift them off the top-hat rail.

3.2.4 Vibration protection

If vibrations are to be expected during operation, the modules can be secured with the end brackets (marked red) supplied with the UO-SCU. These are mounted to the left of the UO-SCU and to the right of the last function module in the system.

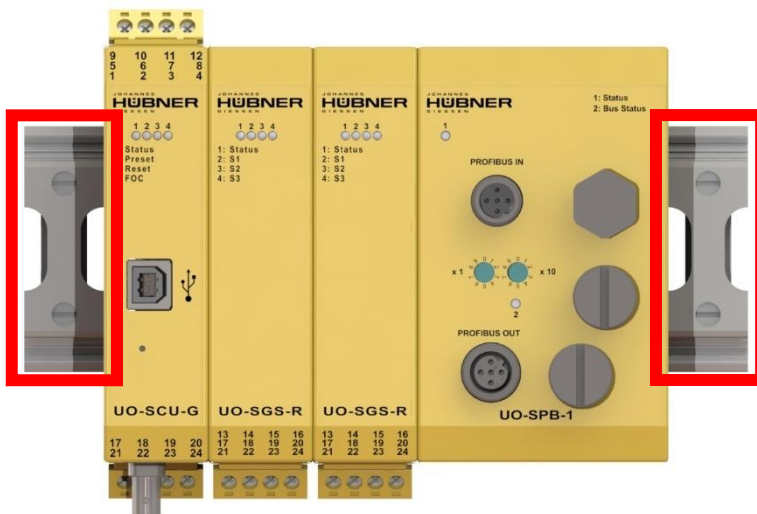

Figure 15: U-ONE function modules secured with end brackets

3.2.5 Connecting the cable shields

To connect the cable shields, first install the shield terminals in the control cabinet. After removing the cable sheathing, connect the cable shields to the machine earth via the terminals. Ensure that all screw connections are tight.

Cable shields must always be connected at both cable ends.



Figure 15: Cable connection terminals for control cabinet mounting

4 Quality assurance

The U-ONE Inspection Report template is available for checking a completed installation. The inspection report contains a list of inspection points.

The U-ONE system records diagnostic messages. It is possible to have the diagnostic memory evaluated by the service department of Johannes Hübner Fabrik elektrischer Maschinen GmbH. Please follow the instructions in the U-ONE application software. Data transmission is largely automatic.